



**PACIFIC**<sup>®</sup>  
F L O O R C A R E

PURPOSE BUILT.™

# **PARTS & OPERATING MANUAL**

## **S-20 & S-24XM, 11 GALLON AUTO SCRUBBERS**

**PLEASE READ THIS BOOK**

---

This operator's book has important information for the use and safe operation of this machine. Read this book carefully before starting the machine. Keep this book near the machine, protected from liquids and other substances that can cause damage to it. If you do not follow the instructions, you can cause an injury or damage equipment, furniture or buildings.

For new books, please download your copy from our website [www.pacificfloorcare.com](http://www.pacificfloorcare.com) or write to:

Pacific Floorcare<sup>®</sup>  
2259 S. Sheridan Drive  
Muskegon, MI 49442-6252

Carefully inspect all components to ensure that there is no concealed freight damage. If such damage is discovered, file a "CONCEALED DAMAGE REPORT" immediately with the delivering carrier.



The contents of this manual are based on the latest product information available at the time of publication. Pacific Floorcare reserves the right to make changes or improvements without being obliged to apply changes to the machines previously sold.













Thank you for purchasing a Pacific Floorcare product. Warranty registration will allow us to better serve you over the lifetime of the product. For quick and easy registration, go to: [www.pacificfloorcare.com/Register Product](http://www.pacificfloorcare.com/Register Product).

# SAFETY PRECAUTIONS

This machine is intended for commercial use. Only use recommended pads or brushes and commercially approved floor cleaning chemical intended for machine application.

The following symbols will be used to warn you of hazards or unsafe practices which could result in personal injury or death:

-  **CAUTION:** INDICATES A POTENTIALLY HAZARDOUS SITUATION WHICH, IF NOT AVOIDED, MAY RESULT IN MINOR OR MODERATE INJURY.
  -  **WARNING:** INDICATES A POTENTIALLY HAZARDOUS SITUATION WHICH, IF NOT AVOIDED, COULD RESULT IN DEATH OR SERIOUS INJURY.
  -  **DANGER:** INDICATES AN IMMINENTLY HAZARDOUS SITUATION WHICH, IF NOT AVOIDED, WILL RESULT IN DEATH OR SERIOUS INJURY.
- 

-  **WARNING:** **Fire or explosion hazard: Never use flammable liquids or operate machine in or near flammable liquids, vapors or combustible dusts.** This machine is not equipped with explosion proof motors. The electric motors will spark upon start up and during operation which could cause a flash fire or explosion if machine is used in an area where flammable vapors/liquids or combustible dusts are present
-  **WARNING:** **Do not pick up flammable or reactive materials.**
-  **WARNING:** **Batteries emit hydrogen gas. Keep sparks and open flame away. Keep battery compartment open when charging. Perform this procedure in a well ventilated area.**
-  **WARNING:** **Electrical hazard. Disconnect battery cables before servicing.**
-  **CAUTION:** **Spinning brush. Keep hands away. Turn off power before working on machine.**
-  **CAUTION:** **Do not operate machine unless trained and authorized.**
- NOTE:** **Do not operate machine unless operator manual is read and understood.**
-  **CAUTION:** **Do not operate machine if it is not in proper operating condition.**
-  **CAUTION:** **When using the machine, go slow on inclines and slippery surfaces.**
-  **CAUTION:** **When using the machine, wear non-slip shoes.**
-  **CAUTION:** **When using the machine, reduce speed when turning.**
- NOTE:** **When using the machine, report machine damage or faulty operation immediately to your supervisor.**
-  **CAUTION:** **When using the machine, never allow children to play on or around it.**
-  **CAUTION:** **When using the machine, follow mixing and handling instructions on chemical containers.**
-  **WARNING:** **When using the machine, do not use the machine as a means for transport.**

# SAFETY PRECAUTIONS

**NOTE:** Do not allow the brush/pad to operate while the machine is stationary to avoid damage to the floor.

 **CAUTION:** Do not bump into shelves or scaffoldings, especially where there is a risk of falling objects.

 **CAUTION:** Before leaving or servicing a machine, stop it on a level surface.

**NOTE:** Before leaving or servicing a machine, turn off the unit and remove the key.

 **CAUTION:** When servicing the machine, avoid moving parts. Do not wear loose jackets, shirts or sleeves

 **WARNING:** When servicing the machine, do not wear jewelry when working near electrical components.

 **WARNING:** When servicing the machine, disconnect battery connections before beginning work.

**NOTE:** Do not power spray or hose off the machine. Electrical malfunction may occur.

 **WARNING:** When servicing the machine, do not work under the lifted machine without supporting it with safety stands.

**NOTE:** When servicing the machine, use manufacturer supplied or approved replacement parts.

**NOTE:** All repairs must be performed by a qualified service person.

 **CAUTION:** When servicing the machine, do not modify the machine from its original design.

**NOTE:** When transporting the machine, turn the machine off.

 **CAUTION:** When transporting the machine, do not lift the machine when batteries are installed.

 **CAUTION:** When transporting the machine, get assistance when lifting the machine.

**NOTE:** Use a recommended ramp with a maximum of a 12° maximum incline when loading or unloading into/off truck or trailer.

**NOTE:** When transporting the machine, use tie down straps to secure the machine to the truck or trailer.

**NOTE:** When transporting the machine, put the scrub head in the lowered position. Make sure the unit is off before doing so.

 **WARNING:** Do not charge the batteries if the battery charger cable or plug is damaged.

 **WARNING:** When charging batteries, do not smoke near the machine.

**NOTE:** When storing the machine, always store it indoors in an area where the temperature is between 32° and 104°F (0° and 40°C)

**NOTE:** Replace any and all safety labels located on the machine if they are missing or become damaged or illegible.

# MACHINE PREPARATION

## UNPACKING & BATTERY INSTALLATION

### UNPACKING THE MACHINE

1. Remove the outer packaging.
2. The machine is fastened to the pallet with tie down brackets. Remove the brackets with a phillips tip in a cordless screwdriver.
3. Using a ramp, push the machine backwards down from the pallet.
4. Keep the pallet and brackets for any future transport needs.

Tie down bracket



### BATTERY INSTALLATION

The machine will be supplied with a battery charger and either two 12V wet or AGM batteries. The batteries must be housed in the battery compartment beneath the recovery tank.

To insert batteries:

1. Lift the recovery water tank, opening it as far as it will go using the side handle.
2. The batteries must be lowered into the compartment using lifting and transportation means suitable for the weight and dimensions.
3. They must be connected together in series, to obtain overall voltage of 24V on the lugs.

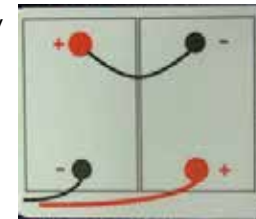

Battery Connection Diagram



Recovery tank shown in fully open position

NOTE: Fully charge the batteries before using the machine.

### BATTERY TYPE

To power the machine you can use either wet batteries or AGM batteries. Other types must not be used.

The maximum dimensions and the weight are:

Width:	12 7/8 in (327 mm)
Length:	7 1/8 in (181 mm)
Height:	10 7/8 in (276 mm)
Weight:	82 lb (37 kg)

**NOTE:** The on-board charger has been programmed to work with the batteries that Pacific Floorcare provides. Using other battery types not specified for the S-20/S-24XM by Pacific Floorcare may impair performance of the unit and will affect the life of the batteries.

**NOTE:** Your charger must be set according to the type of battery you install. Read charging section of manual for further instructions on how to set your charger correctly for your battery type.

# MACHINE PREPARATION

## BATTERY POWER LEVEL INDICATORS

The battery power level gage is located on the upper control panel. The gage has a series of LEDs to indicate the amount of power left in the batteries. When the batteries have a full charge, all LEDs are lit. As the batteries are discharged, the LEDs will begin to go out from right to left. To maximize the life of the batteries, do not allow the LEDs to go beyond the discharge level as described below.

To maximize the life of the batteries, only recharge the batteries when the machine is operated for a total of 30 minutes or more and always recharge the batteries immediately after usage when LEDs are indicating charging is required as described below.

### BATTERY POWER LEVEL INDICATOR - TRACTION DRIVE MODELS

The battery power level gage is located on the upper control panel. The gage has red, yellow and green LEDs to indicate the amount of power left in the batteries.

On lead acid battery-equipped units, when the discharge level reaches the first red LED, it is a good time to finish your scrubbing application and recharge the unit. If you do choose to continue scrubbing, when the last red LED begins to flash, the unit will shut down the brush motor but leave the vacuum and traction drive operational to perform final water recovery and transport back to storage. This function not only serves as an indicator that your battery level has reached a point where recharging is required, but also protects the batteries from being fully discharged.

AGM battery-equipped units should not be used after the last yellow LED goes out leaving only red LEDs. Using the unit beyond this point can reduce the life of the batteries.

**NOTE:** The traction drive battery power level gage also displays fault codes. The LEDs will flash specific fault codes if a fault is detected. See Troubleshooting section for LED fault codes.

### BATTERY POWER LEVEL INDICATOR - PAD/BRUSH ASSIST MODELS

The battery power level gage is located on the upper control panel. The gage has a series of yellow LEDs to indicate the amount of power left in the batteries. When batteries are fully charged, all LEDs are lit. As the batteries discharge, the LEDs will begin to go out from right to left.

On lead acid battery-equipped units, when the discharge level reaches the last, lit LED (2nd in from left) it is a good time to finish your scrubbing application and recharge the unit. If you do choose to continue scrubbing, when last LED begins to flash, the unit will shut down the brush motor but leave the vacuum operational to perform final water recovery. This function not only serves as an indicator that your battery level has reached a point where recharging is required, but also protects the batteries from being fully discharged.

AGM battery-equipped units should not be used after there are only two LEDs lit. Using the unit beyond this point can reduce the life of the batteries.

Recharge lead acid batteries

Recharge AGM batteries

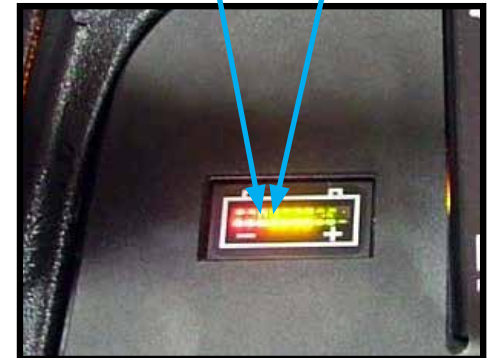

Battery Level Indicator -  
Traction Drive Models

Recharge lead acid batteries

Recharge AGM batteries

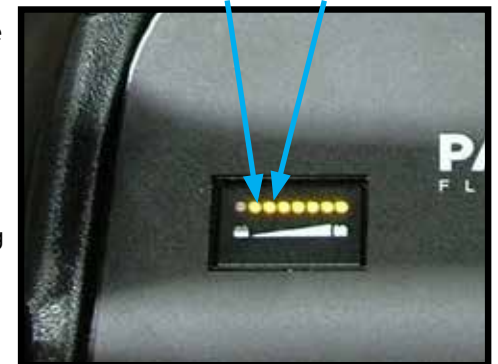

Battery Level Indicator -  
Pad/Brush Assist Models

# MACHINE PREPARATION USING YOUR ON-BOARD CHARGER

## CHARGING THE BATTERIES WITH AN ON-BOARD CHARGER

Before using your S-20/S-24XM for the first time, fully charge your batteries.

- 1 These units can be equipped with an on-board charger.
- 2 The on-board charger is equipped with a 9 foot long cord that can be plugged directly into a 120V outlet. Do not use an extension cord. This will void the warranty on the charger.
- 3 The cord wrap on the unit has a quick-release hook. The lower hook allows the user to slip the cord off and then the cord can be lifted off the upper hook, all without having to unravel the entire cord.

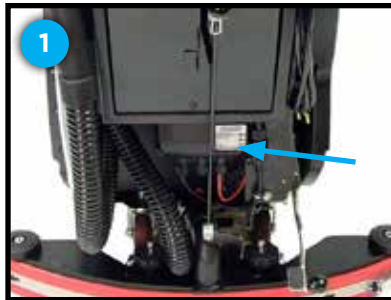

On-board charger



On-board charger cord wrap



Quick release hook

The on-board charger has charging indication LEDs - the red LED means it has just started the charging cycle, the yellow LED indicates that it has reached the second phase of charging and green LED means the unit is fully charged.



Charging indication LEDs

Green indicates charge cycle is complete

Yellow indicates charge cycle is in the second phase

Red indicates charge cycle has just begun

After charging is complete, wrap the cord of your on-board charger securely to ensure the cord is not damaged.

# MACHINE PREPARATION

## SETTING THE DIP SWITCHES ON YOUR ON-BOARD CHARGER FOR YOUR BATTERY TYPE



Use small screw driver to lift label off charger

Both the on-board and off-board chargers are able to charge wet, lead acid or maintenance-free AGM batteries. As your unit leaves Pacific Floorcare's factory, the charger is set up to match the type of battery chosen in the original machine order. Should you choose to change from the original battery type, the charger can be changed by re-setting the dip switches.

**NOTE:** The on-board charger has been programmed to work with the batteries that Pacific Floorcare provides. Using other battery types not specified for the S-20/S-24XM by Pacific Floorcare may impair performance of the unit and will affect the life of the batteries.

To access the dip switches, use a small screw driver to lift the corner of the label on the on-board charger and peel back partially to reveal them. Set the dip switches as shown below for the specific battery type being used in your machine.

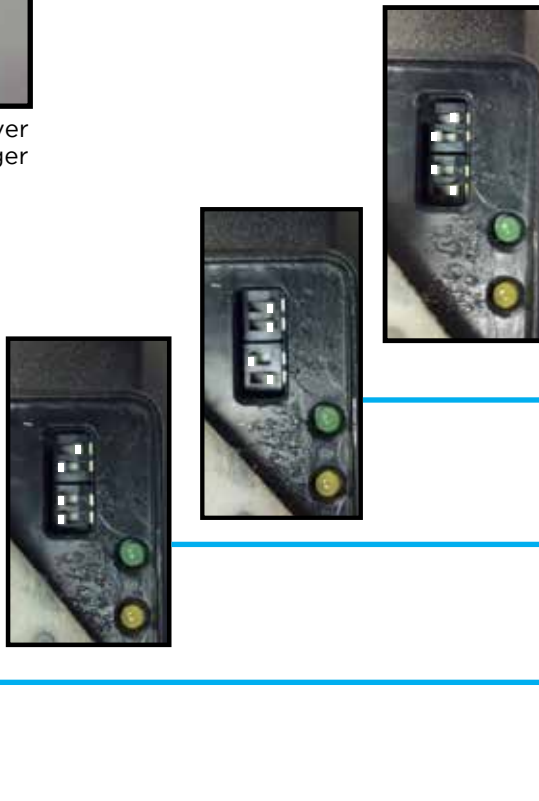

BATTERY PART NUMBER	DIP SWITCHES (TOP TO BOTTOM)				BATTERY DESCRIPTION
851303	ON (R)	OFF (L)	OFF (L)	ON (R)	TROJAN 155AH LEAD ACID
881350	ON (R)	ON (R)	OFF (L)	ON (R)	TROJAN OR CROWN 130AH LEAD ACID
841311	ON (R)	OFF (L)	OFF (L)	OFF (L)	FULL RIVER 140AH AGM
851302	ON (R)	ON (R)	OFF (L)	OFF (L)	FULL RIVER 105AH AGM

# MACHINE PREPARATION USING YOUR OFF-BOARD CHARGER

## CHARGING THE BATTERIES WITH AN OFF-BOARD CHARGER

Before using your S-20 or S-24XM for the first time, fully charge your batteries.

- 1 These units can be equipped with an off-board charger.
- 2 The off-board charger has both a standard 120V power cord and a cord with an “Anderson connector”.
- 3 There is also an Anderson connector on-board the S-20/S-24XM located on the lower control panel at the rear of the machine.
- 4 With the 120V cord plugged into the wall, connect the two Anderson connectors and the batteries to begin charging.



Off-board charger



Anderson connector located on charger cable

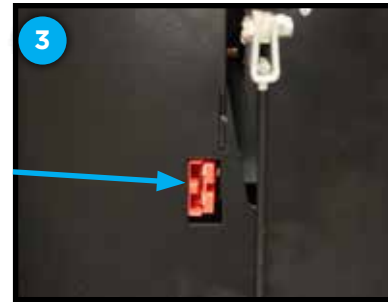

Anderson connector located on lower, rear panel

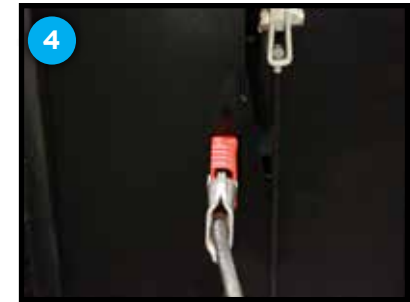

Charger connected to machine

The off-board charger has charging indication LEDs. The primary LED is green and if blinking slowly, then the batteries are still below 80% of full charge. If blinking fast, then the batteries are above 80% of full charge while if solid green, the batteries are fully charged. There is a red “fault” LED as well. In the rare occurrence that this LED comes on, check the charger operator manual for troubleshooting guidance.

Primary indicator light

Fault light



Charging indication LEDs



# MACHINE PREPARATION

## SETTING THE DIP SWITCHES ON YOUR OFF-BOARD CHARGER FOR YOUR BATTERY TYPE

The off-board charger is able to charge wet, lead acid or maintenance-free AGM batteries. As your unit leaves Pacific Floorcare's factory, the charger is set up to match the type of battery chosen in the original machine order. Should you choose to change from the original battery type to the other, the charger can be changed by re-setting the dip switch.

To re-set the dip switch, slide the switch up for wet, lead acid batteries (battery part numbers 881350 or 851303) or down for sealed, maintenance free AGM batteries (battery part numbers 851302 or 841311).

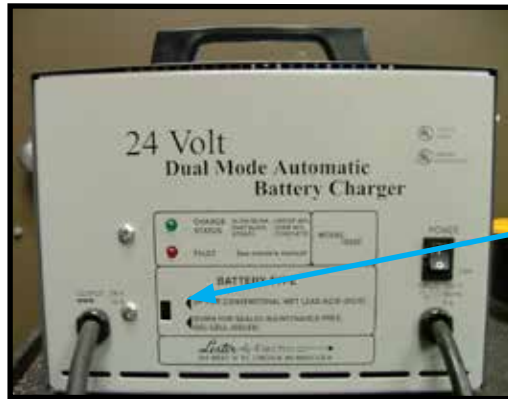

Front view of off-board charger



Close up of dip switch

# MACHINE PREPARATION

## SOLUTION TANK

To prepare the machine for cleaning, the unit must be filled with cleaning solution.

- 1 Water and cleaning agent can be added to the S-20/S-24XM's rear hose fill port located to the left of the control panel.
- 2 There is also a front fill port that is able to accept hose or bucket filling.

Liquid detergent should be added to the tank in the concentration and manner specified by the manufacturer for an eleven (11) gallon solution tank. The formation of excess foam could damage the vacuum motor, so be sure to use only the correct amount of detergent. Water temperature should not exceed 120°F (50°C).

**NOTE:** Always use low-foam detergent. Introduce a small amount of defoaming liquid in the recovery tank before starting work to prevent foam from being generated. Never use pure acids.

- 3 It is easy to gage the solution level by watching the fog-free solution sight gage at the rear of the machine. Additionally, marks on the tank provide solution level indicators as a guide.
- 4 The bottom of the front fill port is also a full level indicator. Once you are able to see water at the base of the opening, you have reached the full level.
- 5 The sight gage hose performs double-duty as the solution drain hose as well. You simply slide the hose off the press fitting and lower the hose to a drain or mop sink.



Rear hose fill port



Front fill port



Sight gage hose



Sight gage hose released from press fitting

Solution level indicators

# MACHINE PREPARATION

## ATTACHING A CLEANING PAD TO YOUR PAD DRIVER - DISK HEAD

If using a floor pad with your pad driver:

- 1 Remove the pad driver by locating the automatic off switch on the lower control panel at the rear of the machine. Depress position "A" for 1 second and then depress position "B" to "click-off" the pad driver(s).
- 2 Place your pad driver(s) on a work surface and remove the center lock fitting from the pad driver. To do so on the S-20, unscrew the center lock in a counter-clockwise motion. For the S-24XM, squeeze the center lock wires inward and lift the center lock off the pad.
- 3 Connect the cleaning pad to the disk pad driver by centering it on the driver.
- 4 S-20: Screw on the center lock fitting, making sure that the center lock has compressed the pad and is snug. S-24XM: Squeeze center lock wires inward and press center lock down, tab side first, compressing the pad and then release the tabs so that they lock in place holding the pad. Repeat for the other pad driver.

**NOTE:** The S-20 and S-24XM pad drivers are tufted pad drivers. Do not use a pad driver on the floor without a pad in place. This will cause damage to your floor.



Depress position "A" for 1 second then depress position "B"

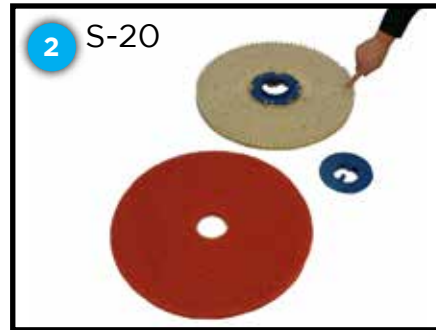

Disconnect center lock fitting & lay next to the pad driver



Center pad on pad driver



Screw on center lock fitting



Disconnect center lock fitting & lay next to the pad driver

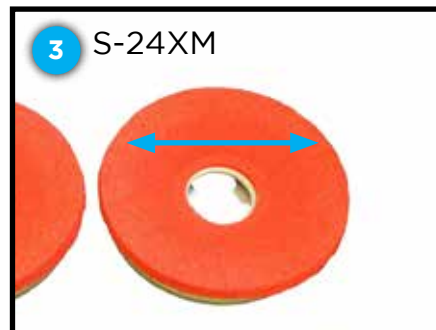

Center pad on pad driver

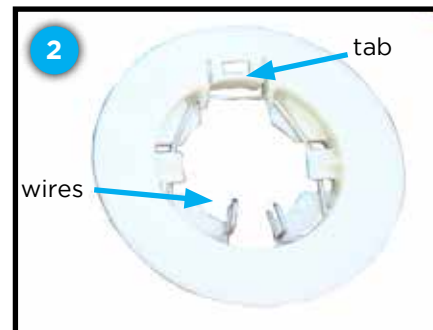

Close up of center lock



Squeeze center lock wires inward, press down onto pad & release wires

# MACHINE PREPARATION

## ATTACHING YOUR PAD DRIVER OR BRUSH TO THE S-20/S-24XM - DISK HEAD

The pad driver(s) or brush(es) are attached by using the automatic on/off system. This valuable ingenuity removes the need for operators to kneel or strain to attach the pad driver or brush.

First, start by placing the pad driver or brush on the floor in front of the S-20/S-24XM scrubber.

- 1 Turn the unit on using the power key switch.
- 2 Push or drive it into position so that the unit's scrub head is centered over the pad driver(s) or brush(es).
- 3 Utilize the foot pedal to lower the scrub deck down onto the pad driver or brush by depressing the pedal while shifting it to the right. Once clear of the lower notch, lifting your foot will lower the scrub deck. Make sure that the shroud completely covers the pad driver(s) or brush(es) in the lowered position. Should the shroud be resting on a portion of the pad driver or brush, the head isn't centered and will not attach properly.
- 4 The operation is completed by quickly pulsing the activation trigger. This will "click on" the pad driver(s) or brush(es). If the pad driver(s) or brush(es) do not quickly engage, do not continue pressing the activation trigger. Realign the scrub deck and try procedure again. When you have the scrub deck aligned properly, you should see a noticeable drop of the scrub deck when lowered and the bristle skirt on the shroud should almost be touching the floor.



1 Turn unit on using key switch



2 Position scrub head over pad driver(s) or brush(es) (S-20 shown)



3 Lower the scrub head using the foot pedal



4 Quickly pulse the activation trigger

# MACHINE PREPARATION

## ATTACHING YOUR PAD - ORBITAL HEAD

### ATTACHING A PAD TO YOUR ORBITAL PAD DRIVER

The orbital unit can be used for daily cleaning; however it specializes in chemical-free finish removal for low-cost finish maintenance programs. The following directions show how to prepare the machine for both applications.

For cleaning, the orbital unit is fit with a rectangular, 20 in (508 mm) x 14 in (356 mm) pad. The head comes standard with a rectangular pad drive plate with a Mighty-Lok® connection system.

- 1 To attach the pad, align the front corners of the pad to the front corners of the orbital drive plate and press to attach.
- 2 Use the foot pedal to lower the scrub deck down onto the pad ensuring alignment from front-to-back and side-to-side.
- 3 When the head is properly set onto the pad, you are ready for cleaning.



Align the front corners of the pad and press to adhere



Lower the scrub head using the foot pedal

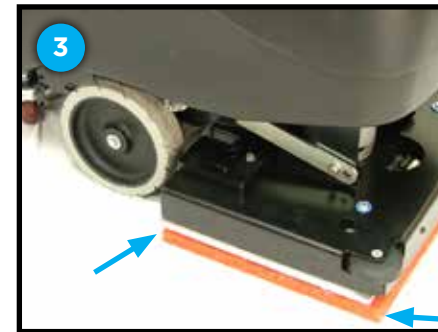

Proper alignment of pad

For chemical-free finish removal, it requires the addition of a specialized surface preparation pad. The application still requires the attachment of a traditional cleaning pad first. This pad acts as a “backer pad” which compensates for low and high spots in the floor.

- 4 Align the Velcro pad retainer along one length of the red, backer pad and press down. This will leave a 2” gap along one side of the backer pad. Then place the surface prep pad on top of the pad retainer, centering it from front-to-back & side-to-side with the red pad. The 2” gap left by the pad retainer needs to be at the front of the machine so that water can fully saturate the pad. Align your pad assembly with all corners of the pad driver and press upward. The red backer pad should be in closest contact with the pad driver.
- 5 Finish the operation by using the foot pedal to lower the scrub deck down onto the surface preparation pad, once again ensuring alignment from front-to-back and side-to-side. When the head is properly set onto the pad, you are ready for your finish maintenance program.



Red backer pad & Velcro pad retainer (black) alignment shown above with surface prep pad (brown) pulled away



Proper alignment of pad

# MACHINE PREPARATION

## CONNECTING THE SQUEEGEE AND ADJUSTING SQUEEGEE HEIGHT

Prior to shipping from the factory, the squeegee assembly is removed from the unit. To connect your squeegee assembly to the machine:

- 1 Align the squeegee assembly retention slots with the easy-grip knobs then tighten until secure.
- 2 Attach the recovery hose to the squeegee assembly neck. Make sure to route the loop hose trap between the squeegee assembly neck and left easy-grip knob.

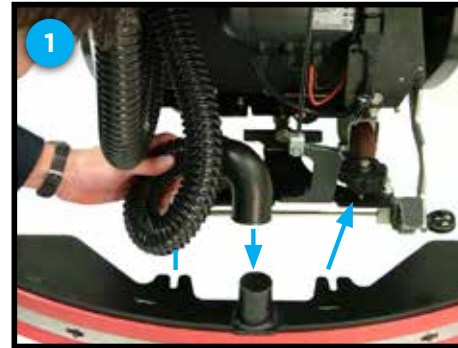

Positioning the squeegee assembly to mount onto the squeegee frame

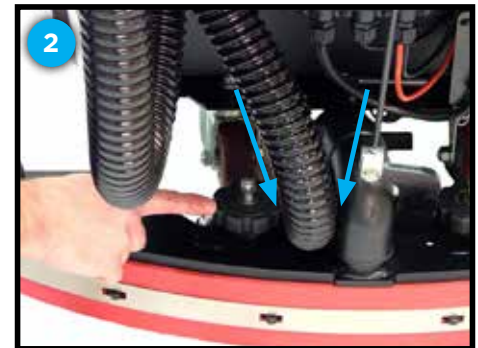

After aligning assembly, tighten the easy-grip knobs and attach the recovery hose.

*\*Arrows indicate proper hose routing*

- 3 The squeegee blade assembly height is factory set at the optimum water recovery position with the squeegee wheels being approximately 1/32 inch (1 mm) off the ground allowing the recovery blade to deflect as shown below.
- 4 If for some reason your squeegee blade height must be adjusted, it is done so by turning the left thumb screw located on the squeegee frame assembly clockwise to raise the left squeegee wheel and counter-clockwise to lower the wheel. The same is true for the right thumb screw/squeegee wheel.

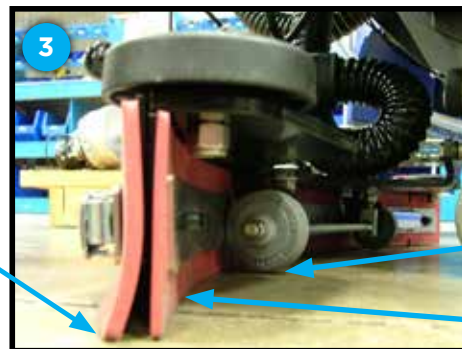

Proper recovery blade deflection

Close up of squeegee assembly and blade deflection

Slight clearance off of floor

No clearance off of floor



Thumb screw to raise and lower squeegee assembly wheels

# MACHINE OPERATION

## OPERATIONAL CONTROLS

The machine operation and controls were designed to minimize operator training and decrease the need for adjustments during operation. Additionally, once in operation, Pacific Floorcare's goal was to provide an ergonomic, easy to use system. Due to this focus, the S-20/S-24XM's key operational controls are all within reach so that the operator doesn't have to remove their hands to perform the operation - a key to safe, trouble-free, highly productive cleaning.

### TURNING THE UNIT ON/OFF

The machine is powered on through a key switch on the upper control panel. Turn the key to the ON position. You will see the battery meter on the left side of the upper control panel light up to show the battery charge level.

The key switch is a proven way to eliminate unwanted operation. Simply remove the key and safely store it away when you have completed scrubbing.



Transaxle drive unit key switch shown above

### SETTING DESIRED SOLUTION FLOW RATE

The next step is to set the unit to the desired solution flow. This control feature is located at the lower rear of the machine and can be adjusted from low to high flow spanning a range of 0 to 0.5 gallons (1.9 L) per minute.



Solution flow adjustment knob

# MACHINE OPERATION

## OPERATIONAL CONTROLS

Once the machine is powered on and the solution flow is set, it takes three simple steps to operate the machine: lower the scrub deck, lower the squeegee and engage the activation trigger. These steps are visually shown on the lower control panel by the S-20/S-24XM's "1, 2, 3-Step" on-board operation guide. Following are the detail steps of how scrubbing and recovery functions are activated.



On-board "1, 2, 3-Step" operation guide

### LOWERING THE SCRUB DECK

The scrub deck is lowered using the foot pedal at the rear of the unit.

- 1 Place your foot on the pedal and depress the lever while shifting it to the right. Once clear of the lower notch, lifting your foot will lower the scrub deck into the operating position.
- 2 The S-20/S-24XM has two down pressure settings. The disk unit has settings of 60 and 90 lb (27 and 40 kg) and the orbital unit has settings of 75 and 100 lb (34 and 45 kg). When the unit is set into operating position with the foot pedal, it is in the lower down pressure position. This position is typically used for daily cleaning of normal soils. However, should you have tough soils or want to perform chemical-free finish removal, engage the higher down pressure setting by lifting the foot pedal lever to the upper notch position. To disengage high down pressure, simply lift and shift the lever to the right and lower into normal operating position.
- 3 The disk scrub head is equipped with a self-adjusting shroud with bristle skirt that virtually eliminates overspray and increases ease of use.



Lowering scrub head using foot pedal



Locking in high down pressure setting by lifting foot lever



Self-adjusting head shroud with bristle skirt (S-20)



Self-adjusting head shroud with bristle skirt (S-24XM)



# MACHINE OPERATION

## OPERATIONAL CONTROLS

### LOWERING THE SQUEEGEE

To lower the squeegee, lift the squeegee lever and shift it left to clear the notch. Once clear, lower the squeegee into the recovery position. In doing so, the S-20/S-24XM's vacuum motor will activate.



Lowering the squeegee assembly

### ACTIVATING THE SCRUBBER

- 1 To begin scrubbing, engage the handle trigger. The trigger activates solution flow, the brush motor and traction drive, if equipped. This unique, ergonomic design accommodates different operator heights by allowing the user to activate the trigger from any position on the handle.
- 2 The speed control and reverse switch on the traction drive models are purposely located so that the operator doesn't have to let go of the machine with either hand to perform the function. Speed control is easily thumb adjusted and the reverse can be depressed with your fingers on the back side of the control housing.
- 3 This one-handed reverse feature allows the operator to lift the squeegee with the other hand – a small element with big rewards when in tight spaces.



Activating the handle trigger



Speed control adjustment



Reverse switch is easily reached with fingertip

# MACHINE OPERATION

## OPERATIONAL CONTROLS

### TRANSPORT MODE

The scrub deck and squeegee must be in the raised position for transport.

- 1 The scrub deck is raised into transport position by placing your foot on the foot pad and depressing the lever until it clears the lower notch. Once clear, shift the lever to the left and place it into the lower notch.
- 2 To raise the squeegee, lift the squeegee lever high enough to clear the notch, shift it to the right and lower it into the resting position. On traction drive models, the vacuum fan will continue to run for 10 seconds in order to evacuate the recovery hose. On pad/brush assist models, the vacuum fan will shut off immediately.

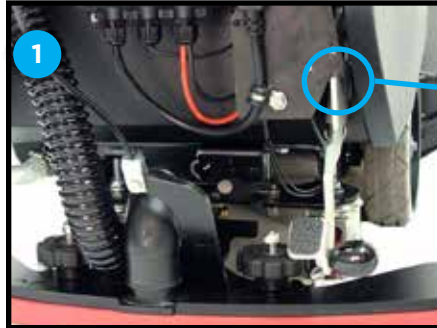

Scrub deck in transport/storage position

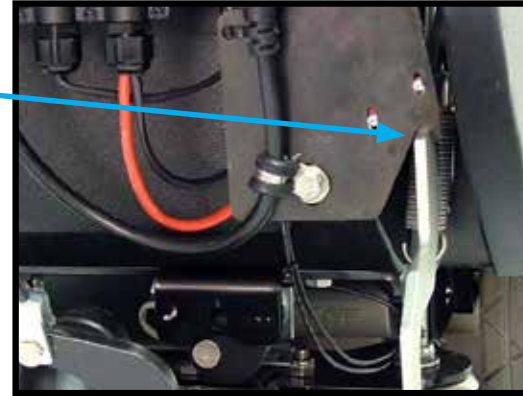

Squeegee assembly in transport/storage position



## MAINTENANCE SCHEDULE FOR SERVICE

MAINTENANCE	DAILY	WEEKLY	MONTHLY	EVERY SIX MONTHS	100 HOURS	200 HOURS
Clean squeegee assembly. Check blades for wear or damage. Check if adjustment needed to squeegee height	X					
Clean out recovery tank inside and out and float shut off assembly. Check both for damage. Leave recovery tank open during storage	X					
Clean pad / brush and check for wear or chemical build up	X					
Check handles, knobs and switches for damage	X					
Charge batteries (if machine used longer than 30 minutes)	X					
Check hoses for wear, blockages or damage	X					
Clean outside of solution tank and clean inline solution filter. Check both for damage		X				
Check wet battery water level and add distilled water if necessary		X				
Check splash guard around scrub head for damage (disk models only)		X				
Thoroughly clean entire machine		X				
Check linkages and connectors for wear / damage			X			
Check all bearings and wheels for noise or loose hardware			X			
Check recovery tank lid gasket for wear or damage			X			
Check batteries for cracks, corrosion or signs of overheating			X			
Check belt for excessive wear (S-24XM only)			X			
Check all screws and nuts. Tighten if necessary			X			
Inspect isolators (orbital units only)				X		
Check for loose wires or connections				X		
Clean batteries and terminals					X	
Blow out dust in motors						X
Clean pivot points on squeegee and scrub deck linkages						X

**NOTE:** With regular maintenance, the lifetime of your machine and its safe operation are extended and ensured. Scheduled maintenance should be performed by qualified personnel or by an authorized service center.

 **WARNING:** These maintenance procedures must be performed with the machine off and the batteries disconnected. Make sure to read all safety instructions prior to performing maintenance.

## MAINTENANCE END OF SHIFT

Once you've completed your daily scrubbing, project work or finish maintenance, proper end of use maintenance can greatly extend the machine's life, improve performance, enhance sanitization and lower the machine's long-term operational costs. There are four key areas we will review and demonstrate: the recovery tank, squeegee assembly, battery maintenance and charging, ending with pad and brush maintenance.

### RECOVERY TANK

At the end of the job, the recovery tank needs to be emptied and rinsed out. To drain the recovery tank, utilize the recovery tank drain hose at the rear of the machine.

- 1 The drain hose has a press-fit cap that is removed for the draining process.
- 2 The hose is also equipped with a restriction collar that can be bent or squeezed to reduce splashing and spraying during the operation.
- 3 As the recovery tank drains, lift the recovery tank lid to the fully open position. When almost empty, begin to rinse out the sediment from the bottom of the tank with a clean water hose. After the tank is thoroughly rinsed and drained, leave the tank lid open to dry.
- 4 This is a great time to inspect and clean the vacuum mesh filter screen and ball float system. This can be removed for cleaning by unscrewing the filter screen and rinsing it with a hose or faucet.

The full access tank is designed for periodic deep cleaning and sanitizing. Once thoroughly rinsed, the operator can use a cleaner and sanitizer with a cloth or sponge to completely sanitize the recovery tank. This reduces the mold and mildew that can form over time.



Recovery tank drain hose



Drain hose has a press-fit cap and restriction collar



Raising recovery tank lid to fully open position



Vacuum mesh filter screen and ball float system

# MAINTENANCE

## END OF SHIFT

### SQUEEGEE ASSEMBLY

The squeegee system is crucial to high-performance cleaning. It is the last thing that touches the floor so proper maintenance is important for making it perform at its peak.

- 1 Remove the squeegee assembly from the machine by loosening the easy-grip knobs and detaching the recovery hose at the back of the machine. Take the squeegee to a drain or utility sink and thoroughly rinse the underside of the squeegee frame and squeegee blades. Make sure that all particles and debris have been removed. Inspect the neck of the squeegee assembly for debris. If found, clear the debris and rinse it out.
- 2 Inspect the front and rear squeegee blades. If the blade edges are not clearly defined or worn halfway through the thickness of the blade, then it is time for replacement or to be flipped to another edge. The S-20/S-24XM's squeegee blades have four usable edges.
- 3 Blade exchange is completely tool-free for fast, easy maintenance. To remove the rear blade, release the over-center latch and slide the squeegee retainer off the hook on the other side.
- 4 The blade can be removed for replacement or flipped length wise or top to bottom to utilize another blade edge.

To re-attach the blade, align the blade holes with the squeegee frame guides from one end to the other. Slide the retainer over the hook and press the retainer latch into position on the far end following the guides. Engage the latch to finish the operation.

The front-blade exchange is completed in a similar fashion to the rear blade by removing the front blade retainer, attaching a new blade using the guides and re-engaging the squeegee retainer.

When squeegee assembly and blade maintenance is complete, re-attach the squeegee assembly by aligning the assembly, tightening the easy grip knobs and re-attaching the hose.



Remove squeegee assembly



To flip or replace squeegee blades, release over-center latch



Slide the squeegee retainer off the hook on the other side



Remove the blade and either flip to fresh edge or replace

# MAINTENANCE

## END OF SHIFT

### BATTERY MAINTENANCE

Based on research and experience, batteries are the number one nuisance issue and drive a high cost of ownership if not properly maintained. With the S-20/S-24XM, you can select from two types of batteries: wet, lead acid or sealed, maintenance-free AGM.

### WET, LEAD ACID BATTERY MAINTENANCE

Wet batteries, by definition, need water to store energy and protect the internal lead plates. According to the supplier, here are important things to remember for a proper battery watering process:

1. Do not let the plates get exposed to air. This will corrode the plates
2. Do not fill the water level to the cap. This causes the battery to overflow acid, consequently losing capacity and causing a corrosive mess
3. Use distilled or deionized water only

### STEP BY STEP BATTERY WATERING PROCEDURE

Battery watering frequency depends upon usage, but the best practice would be to check weekly. Batteries should be fully charged prior to watering. Refer to the Charging segment of this manual for charging instructions. Once charging is completed, open the vent caps and look inside the fill wells. Add distilled water until the electrolyte level is approximately 1/8 in (3.2 mm) below the bottom of the fill well. Clean and replace the vent caps.

**⚠ WARNING: Fire or explosion hazard. Batteries emit Hydrogen gas. Keep sparks and open flame away. Keep battery compartment open when charging.**

**⚠ CAUTION: For safety, when cleaning batteries, wear protective gloves and eye protection. Avoid contact with battery acid.**

### HYDROLINK® BATTERY WATERING SYSTEM

HydroLink® is a series of specialized battery caps, tubes and a hand pump that formulates a single-point battery watering. There is no need to check or fill individual battery cells with this accessory.

HydroLink® comes with an independent, non-mechanical water level indicator that is simple to read. A white indicator means that the battery needs water and a black indicator means that the battery has enough water.

After the batteries are charged and the operator has identified that the batteries are low with the indicator, place the feed hose into a reservoir of distilled water and compress the hand-pump until it becomes hard to squeeze. This indicates that all the battery cells are filled to the proper level.



HydroLink® battery watering system

# MAINTENANCE

## END OF SHIFT

### BATTERYSHIELD™ AUTOMATIC WET BATTERY PROTECTION SYSTEM

If your scrubber is equipped with BatteryShield technology, your scrubber will provide you “real time” notification when your wet batteries need to be watered.

After your machine is charged and you turn the key switch on, BatteryShield will check your water levels for you. You can locate the BatteryShield optical sensor on the HydroLink® cap on your battery pack and the LED on the back panel of your scrubber.



BatteryShield optical sensor on Trojan battery



BatteryShield LED on back panel



HydroLink battery cap light pipe circled above

When your LED remains unlit, it means that your batteries have an acceptable water level. If BatteryShield senses that your batteries need to be watered, the LED will indicate this with a solid, red light and BatteryShield will not allow your brush motor to function, therefore preventing further use of the scrubber until the batteries are filled with distilled water using the HydroLink single-point battery watering system. After filling your batteries, cycle the key switch off then on and your BatteryShield system will be reset.

BatteryShield has been programmed to check the water levels of your batteries after a full charge, so your unit will most likely be in your janitor's closet or storage area but if by chance it detects low water during the cleaning operation, it will only shut down the brush motor preventing the operator from doing any further cleaning. The vacuum motor and transaxle drive motor will still be operable so that any remaining solution can be recovered and the unit can be transported back to an area where the batteries can be watered.

If your LED has a blinking, red light it means that a HydroLink light pipe needs to be cleaned.

**⚠ CAUTION: For safety, when cleaning batteries, wear protective gloves and eye protection. Avoid contact with battery acid.**

Remove the HydroLink battery cap that has the BatteryShield optical sensor attached to it. **Do not remove the BatteryShield sensor from the HydroLink cap.** Use a clean, damp cloth to wipe the pointed tip and shaft of the light pipe. Snap the HydroLink cap back into place on the battery. Cycle the key switch. The BatteryShield LED should stop blinking if light tube has been cleaned effectively. If repeated attempts to clean the light pipe are unsuccessful, a new HydroLink cap will be required.

# MAINTENANCE

## END OF SHIFT

### PAD DRIVER AND BRUSH MAINTENANCE

This portion of maintenance is simple and quick, but key to keeping your S-20/S-24XM performing at peak levels. Remove the pad driver or brush to check for wear.

- 1 To remove the pad driver or brush from your disk unit, locate the automatic off switch on the lower control panel at the rear of the machine. Depress position “A” for 1 second and then depress position “B”.
- 2 This will “click-off” the pad driver or brush.
- 3 For the orbital unit, simply pull off the pad taking care to follow proper safety precautions as indicated on your chemical product label in regards to coming in contact with solution.

Should the pad or brush show ample wear and have reached their replacement point, simply discard the pad or brush and replace it at the beginning of your next shift. Brushes should be replaced when the bristle length reaches 3/4 in (19 mm).

Alternatively, if not worn out, you can extend the life of your pad driver, pad or brush by rinsing out any captured debris or sediment and then hanging it to dry between shifts - a simple step that can lower your cost to clean.



1 Depress position “A” for 1 second then depress position “B”



2 Cleaning tool released by auto on/off feature (S-20 disk)



2 Cleaning tool released by auto on/off feature (S-24XM)



3 For pad removal on the orbital unit, simply pull off the pad



## PERIODIC MAINTENANCE CHANGING BATTERIES

To change the batteries in your S-20/S-24XM, move the machine to an area with a level surface, turn off the power switch and remove the key. If using an off-board charger, make sure that it is located near your machine and that your location is close to an electrical outlet for charging after installation.

- 1 To access the battery compartment, tilt the recovery tank to the fully open position.
- 2 Using proper open-ended wrench, disconnect the main ground cable first and secure terminal away from the batteries. Disconnect main positive cable and secure terminal away from the batteries. Loosen both terminals on jumper cable and remove. Attach a suitable battery lifting device and lift the batteries from the machine.
- 3 Reverse the order of the instructions above to install new batteries by orienting and connecting the batteries as shown in the Battery Connection Diagram. After installation is complete, be sure to charge your batteries before operating the machine.

**NOTE:** If changing battery types from wet, lead acid to AGM or vice versa, see Machine Preparation section for instructions on setting the dip switches on your machines battery charger before beginning the charge cycle to avoid damaging or undercharging your batteries.

**WARNING:** Batteries are a potential environmental hazard. Consult a battery supplier for safe disposal methods.

**WARNING:** Wear protective gloves and eye protection when handling batteries or battery cables. Avoid contact with battery acid.

**WARNING:** Disconnect battery connections before working on the machine.

**WARNING:** Short-circuiting or accidentally connecting battery posts or other metallic parts of the machine with a metal or conductive tool can cause serious personal injury. Use proper tools and take precautions to not accidentally short circuit battery terminals.



To access battery compartment, tilt recovery tank to fully open position



Fully open position allowing access to battery compartment

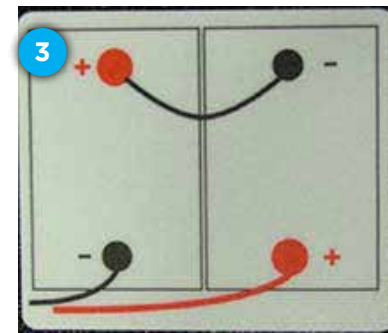

Battery Connection Diagram

## PERIODIC MAINTENANCE

### CHECKING THE ISOLATORS ON YOUR S-20 ORBITAL UNIT

Your S-20 orbital scrubber is equipped with an hour meter that is located on the upper control panel.

- 1 After 300 hours, it is time to check the eight isolators located in the scrub head of the unit.
- 2 Using a flashlight, do a visual inspection of the isolators by looking through the openings in the scrub head and checking for wear or damage to four isolators in the front and four in the rear of the scrub head. The locations of the isolators are shown below.

If any of your isolators show signs of wear, degradation or damage, contact an authorized service center or Pacific Floorcare technical service to find a local authorized service center to replace all eight isolators.

After satisfactory inspection or replacement, press and hold the gray button on the hour meter to reset to another 300 hour period.

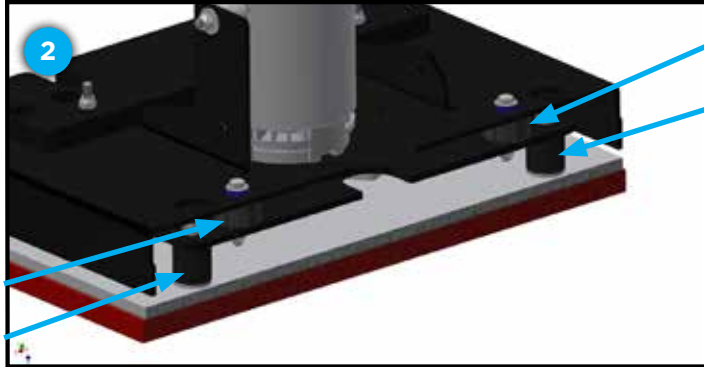

Cross section view of FRONT of orbital scrub head with isolator locations indicated with arrows

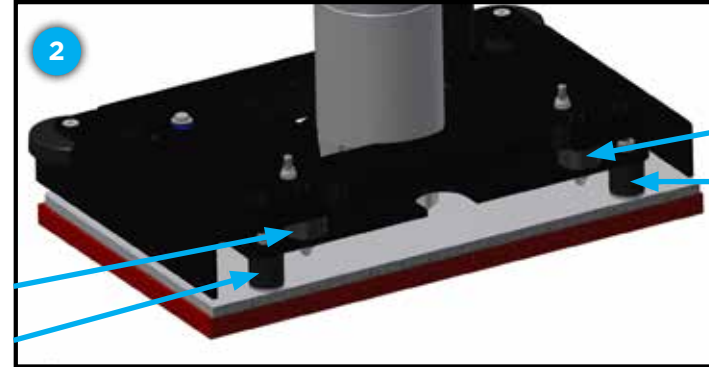

Cross section view of REAR of orbital scrub head with isolator locations indicated with arrows

## TRANSPORTING YOUR UNIT

Your S-20/S-24XM was designed so that it could easily be transported on a route cleaning program.

- 1 The machine has a tie down holes on each side of the main frame.
- 2 It can also be strapped down to a trailer or truck bed using tie down straps inserted between the recovery tank and solution tank

**NOTE:** When transporting the machine, turn the machine off.

**CAUTION:** When transporting the machine, do not lift the machine when batteries are installed.

**CAUTION:** When transporting the machine, get assistance when lifting the machine.

**NOTE:** Use a recommended ramp with a maximum of a 12° incline when loading or unloading into/off truck or trailer.

**NOTE:** When transporting the machine, use tie down straps to secure the machine to the truck or trailer

**NOTE:** When transporting the machine, put the scrub head in the lowered position. Make sure the unit is off before doing so.

**NOTE:** Do not allow the orbital head to rest on a hard surface without a pad attached. This will cause damage to the Mighty-Lok® face.



Tie down location on main frame



Tie down locations between recovery tank and solution tank

# TROUBLESHOOTING

## OPERATOR TOP FIVE TROUBLESHOOTING LIST

Because cleaning equipment can encounter a wide array of environments and debris, various issues can arise that can be quickly fixed with some easy troubleshooting by the operator. Because there are so many scenarios, we've generated the top five troubleshooting list that addresses the most common issues.

### 1. MACHINE ISN'T PICKING UP WATER OR IS LEAVING A FILM ON THE FLOOR

If your machine isn't picking-up water, there are a few key areas of the machine to check. If the vacuum seems to have a higher pitch than normal, the ball float in the recovery tank has tripped because the recovery tank is full and needs to be drained. Once drained, check that the water recovery is working. If it is, then you've identified and corrected the issue.

- 1 If still not picking-up water, then it is likely you have a clog in the recovery hose. Start by checking the recovery hose at the lower elbow connected to the squeegee assembly.
- 2 Then, check the upper elbow and the recovery tank orifice. If debris is found, clear the clog with your hands or a tool. Should you have a hose available, rinse the recovery hose and tank orifice to ensure all the debris is removed.
- 3 If a clog isn't identified in the recovery hose, check the squeegee neck by loosening the easy grip knobs, removing the squeegee assembly and flipping it over. Clear the debris, and again, if a hose is available, rinse the squeegee opening.
- 4 If still not recovering properly, check your rear squeegee blade edge for wear or debris. If debris is present, clean the blade. If the edge is worn to half the blade thickness, flip to a new blade edge or order a replacement blade.

Finally, should you still have recovery issues, contact your distributor or Pacific Floorcare for technical support.

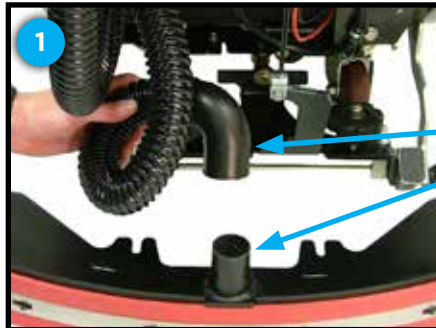

Lower elbow of recovery hose and squeegee assembly neck



Upper elbow of recovery hose and recovery tank orifice



After checking for wear, wipe the blade or flip it to a new edge

# TROUBLESHOOTING

## OPERATOR TOP FIVE TROUBLESHOOTING LIST

### 2. MACHINE RUN TIME HAS DECREASED

If the machine run time has decreased, there are three potential issues that must be checked: The charger may not be plugged in or working, the wet, lead acid batteries may need watering or the batteries need to be replaced.

First, check the charger by plugging it in.

- 1 If an on-board charger, check the three LEDs. If none are on, then you likely have a faulty charger and it will need to be replaced. However, if the lights are on and the red or yellow light is on, then the batteries aren't fully charged and the charge cycle needs to be completed. If the green light is on, then the charger is working and the next step is to consider the batteries.
- 2 If an off-board charger, check the charge status LED. If it is not lit or blinking, then you likely have a faulty charger and it will need to be replaced. However, if the light is on and is blinking then the batteries aren't fully charged and the charge cycle needs to be completed. Also, check for the fault LED to be lit and if so, review the manual that comes with your off-board charger for fault details.

If the batteries are wet, lead acid batteries, check the water levels in the battery cells. If they require watering, refer to the Battery Watering segment of this manual.

If the batteries don't require watering and are over 18 months old, you've likely started to reach a point in the battery's life where their capacity is starting to decline. If you are able to meet your run time requirements, then you still have some useful life left. However, if the capacity has reduced the run time to below your requirements, then it is time to replace the batteries. See Changing Batteries segment of this manual for further instructions on how to replace your batteries.

If none of these factors are present and you are still not getting expected run times, contact your distributor or Pacific Floorcare for technical support.

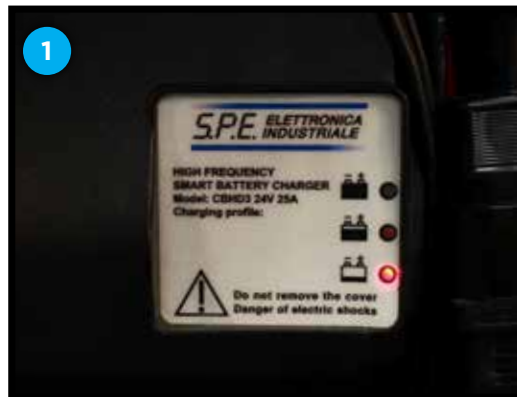

On-board charger LEDs

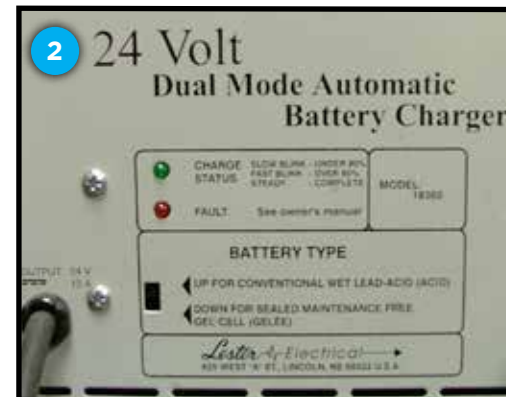

Off-board charger LEDs

# TROUBLESHOOTING

## OPERATOR TOP FIVE TROUBLESHOOTING LIST

### 3. MACHINE WON'T DISPENSE WATER

- 1 First, when this issue occurs, check the solution tank sight gage for water level. If empty, fill the tank with cleaning solution.
- 2 Check the solution flow adjustment knob and ensure that the knob is adjusted to the solution flow level you desire.
- 3 If there is solution in the sight gage and the solution flow adjustment knob is properly positioned, then the filter is likely clogged with debris and needs to be cleaned. Start by draining the solution tank. Unscrew the inline filter, located on the underside of the unit between the wheels and the casters, and clean out the debris. Once clean, re-attach the filter and tighten it until snug. Ensure the screen filter element is aligned properly with the body of the filter during reassembly. Fill the solution tank and check for solution flow. If solution is flowing, you've identified the issue and you can return to cleaning.
- 4 Check the wire connections to the valve.

If none of the actions listed above fix the solution flow, contact your distributor or Pacific Floorcare for technical support.



1 Check sight gage hose for solution level



2 Solution flow adjustment knob and wire connections

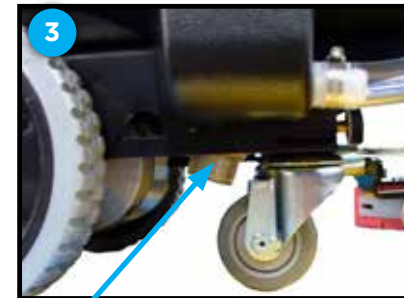

3 Sight gage hose



Inline filter screen

Inline filter cap

Sight gage hose

# TROUBLESHOOTING

## OPERATOR TOP FIVE TROUBLESHOOTING LIST

### 4. RECOVERY TANK NOT DRAINING

If your recovery tank is not draining, there is a clog somewhere in the draining system. The two main areas of potential clogging are at the tank drain or at the restriction collar on the drain hose.

- 1 Start by checking the restriction collar being sure to keep the hose well above the top of the recovery tank so that the water doesn't splash out once the debris is cleared. If the clog is located here, clear the clog with your hand or a tool and then drain as normal.
- 2 If the clog is not located at the restriction collar, then it is likely in the recovery tank at the drain opening. In this case, we suggest that the operator put rubber gloves on prior to submerging their hand to check for the clog. Once the clog is found, clear the drain and then empty as normal.

In the unlikely event that the clog is in another part of the drain hose, we encourage utilizing a water hose to back flush the clog from the recovery hose. Of course, a long thin tool of some kind can be used as well, but be extremely careful not to puncture the hose wall.

If a clog isn't found in the system, contact your distributor or Pacific Floorcare for technical support.



Check for clog in the restriction collar



Check for clog in the recovery tank at the drain opening

## TROUBLESHOOTING

### OPERATOR TOP FIVE TROUBLESHOOTING LIST

#### 5. SQUEEGEE ISN'T PICKING UP WATER IN TIGHT TURNS

The squeegee is designed to swing fully from left to right to the point where the squeegee system almost touches the casters. Should it be stopping well short of this, then it is likely that the recovery hose is not routed properly and has become an obstruction.

- 1 To fix this, route the recovery hose to have the loop hose trap between the squeegee assembly neck and left easy-grip knob.

If this isn't the issue, contact your distributor or Pacific Floorcare for technical support.

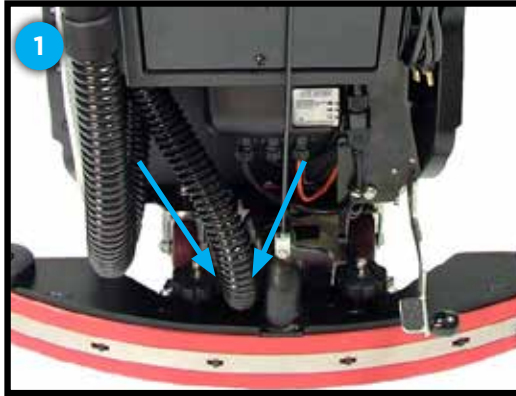

Properly routed loop hose trap placed between knob and recovery hose elbow



## TROUBLESHOOTING GUIDE

ISSUE	POTENTIAL CAUSE	PROPOSED SOLUTION
Insufficient water to the brushes	Solution flow setting is too low	Make sure the solution control valve is open by adjusting the solution flow knob
	Solution tank is empty	Check the sight gage for solution level. If low or empty, add water and detergent
	Inline solution filter may be clogged	Remove inline filter cap & screen to check for clog. Rinse and put back in place
	Solution dispensing tubes may be clogged, kinked or damaged	Visually inspect tubes
Squeegee isn't drying the floor well	Squeegee blades may be dirty or worn	Remove the squeegee assembly, rinse it off and wipe the blades down. Inspect edges for damage or wear. Flip or replace blades as needed
	Recovery hose may not be secure at connections	Make sure upper recovery hose elbow is secure at the recovery tank orifice. Make sure that lower recovery hose elbow is secure on squeegee assembly neck
	Recovery hose or squeegee assembly may be obstructed	Remove recovery hose and run water through it to check for any clogs. Remove squeegee assembly and check for a clog in the neck of the assembly
	Recovery hose may be damaged	Check for damage. Replace if damage found
	Squeegee assembly height may be out of adjustment	Check the squeegee height. See Machine Preparation segment of manual for squeegee height adjustment instructions
	Ball float may be damaged or clogged and it is obstructing air flow	Check to see that the ball float is moving freely and is clean
	Recovery tank is full	Empty recovery tank
	Recovery tank lid is not sealing	Make sure that the lid is in the proper position and that there isn't damage to the gasket. Replace gasket if damage found
	Drain hose cap may be loose	Make sure cap is clean and has been pressed in tightly
	Batteries may be discharged	Check battery indicator and if necessary, recharge batteries
Machine will not turn on	Key switch may be faulty	Contact a service center to have tested
	A fuse may be blown (pad assist unit only)	Replace fuses
	Batteries may be discharged	Charge your batteries until charger indicates cycle is complete
	Batteries may be faulty	Replace batteries
	Battery cable(s) may be loose	Check connections and tighten if necessary
	Handle trigger isn't activated	Follow instructions in Machine Operation segment of manual or "1, 2, 3-Step" on-board instructions

## TROUBLESHOOTING GUIDE

ISSUE	POTENTIAL CAUSE	PROPOSED SOLUTION
Machine isn't cleaning satisfactorily	Pad or brush may be worn	Inspect & replace if necessary. Brushes should be replaced when the bristles reach a length of 3/4 in (19 mm)
	S-24XM belt is worn	Replace belt
Excessive foam is being produced in the recovery tank	Detergent used is not a low foaming detergent	Check bottle label. Use low foaming detergent or add a small quantity of defoamer to the recovery tank. More foam is generated when a floor is lightly soiled. Use less detergent if this is the case
Brush motor will not activate	Scrub head is still in the transport/storage position	Lower scrub head to operating position
	Batteries are discharged to the point that the brush motor is shut down	Recharge the batteries
	Brush motor or wiring may be faulty	Contact a service center for testing
	Brush motor circuit breaker has been tripped	Reset brush motor circuit breaker on back panel of scrubber
	Brush motor relay may be faulty	Contact a service center for testing
	Scrub head switch may be faulty	Contact a service center for testing
	Handle switch may be faulty	Contact a service center for testing
Vacuum motor will not turn on	BatteryShield system is indicating the batteries need water	Use the HydroLink system to fill the batteries with distilled water
	Squeegee is still in transport/storage position	Lower squeegee to operating position
	Vacuum motor relay may be faulty	Contact a service center for testing
Traction drive (if equipped) does not activate	Vacuum motor or wiring may be faulty	Contact a service center for testing
	Traction drive motor circuit breaker has been tripped	Reset traction drive motor circuit breaker on back panel of scrubber
	Speed control knob is turned too far to the left	Rotate knob to the right
	Traction drive motor or wiring may be faulty	Contact a service center for testing
Run time is short	Traction drive motor controller may be faulty	Contact a service center for testing
	Batteries are discharged	Recharge the batteries for a full cycle
	Wet batteries may need to be watered	See End of Shift Maintenance segment of manual
	Batteries are defective	Replace batteries
	Battery charger is defective	Repair or replace charger
	Scrub head is locked in high down pressure setting	Change scrub head setting from high down pressure setting to normal operation setting
Charger is set to incorrect battery type	Verify dip switch setting is correct on charger using Setting the Dip Switches segment in the Machine Preparation segment of this manual	

## TROUBLESHOOTING GUIDE

### BATTERY POWER LEVEL INDICATOR FAULT CODES

<b>TRANSAXLE DRIVE UNITS</b>		
<b>CODE (FLASHING LEDs)</b>	<b>POTENTIAL CAUSE</b>	<b>PROPOSED SOLUTION</b>
One	Low voltage shut-off. Brush motor shut down	Recharge batteries
		Check battery connections
Two	Battery charge level getting low	Recharge batteries
Three	Traction drive motor tripped	Remove overload condition and reset
	Traction drive motor has short circuited	Contact a service center for testing
Four	Battery lockout has occurred	Recharge batteries right away
Eight	Controller tripped	Contact a service center for testing
Ten	High battery voltage reading	Check battery connections
None	Indicator is in sleep mode	Turn power key off then on to restore
Sequencing lights	Activation handle is engaged	Release activation bail

## SUGGESTED SERVICE PART LISTING

SUB-ASSEMBLY	DESCRIPTION	PART NUMBER	S-20 TRACTION DISK QTY	S-20 PAD ASSIST DISK QTY	S-20 ORBITAL QTY	S-24XM QTY	OPTIONS QTY
Charger, On-board	Cord, 9 ft (3 m)	908128*					1
BatteryShield™	Sensor Assy, BatteryShield	878520					1
Electronics	Controller, traction	859101	1		1	1	
Electronics	Contactora, 24VDC, 100 amp	912401	1	1	1	1	
Electronics	Contactora, 24VDC, 70 amp	912402	2	2	1	2	
Frame	Wheel, traction, 8 in (203 mm)	859704	2		2	2	
Frame	Wheel, 8 in (203 mm)	859702		2			
Frame	Caster wheel, 3 in (76 mm)	859709*	2	2	2	2	
Frame	Caster rig	857502	2	2	2	2	
Frame	Filter, inline	843319	1	1	1	1	
Frame	Valve, solenoid	855014	1	1	1	1	
Head	Motor, brush	855201	1	1			
Head	Guide, driver	853803*	1	1		1	
Head	Guide, driver	873802				1	
Head	Guide, pad	853804*	1	1			
Head	Guide, pad	873801*				2	
Head	Plunger, spring	857002*	1	1		1	
Head	Wheel, guide	859703	1	1	2	1	
Head	Mount, isolator	855604			4		
Head	Motor, 2200 rpm	855204			1	1	
Head	Bearing, .50 inch, sealed	902035				6	
Head	Bearing, .75 inch, sealed	902053				4	
Head	Belt, V-groove	903046*				1	
Head	Center lock, pad driver, replacement	504470*	1	1			
Head	Center lock, pad driver, replacement	875113*				2	
Head	Plate, clutch, with screws	876614	1	1		2	
Controls	Circuit breaker, 30 amp	911622	2	1	2	2	
Controls	Switch, snap, with roller	911646	1	1	1	1	

\*Indicates wear item

## SUGGESTED SERVICE PART LISTING

SUB-ASSEMBLY	DESCRIPTION	PART NUMBER	S-20 TRACTION DISK QTY	S-20 PAD ASSIST DISK QTY	S-20 ORBITAL QTY	S-24XM QTY	OPTIONS QTY
Controls	Switch, push, on/off	911649	1	1		1	
Controls	Key, replacement, set of 2	855012	1	1	1	1	
Controls	Pot, speed	911664	1		1	1	
Controls	Switch, push, reverse	911653	1		1	1	
Controls	Cable, lift, clevis	852401	1	1	1	1	
Controls	Bearing, rod end	902050	1	1	1	1	
Recovery	Hose, drain, capped	854101*	1	1	1	1	
Recovery	Gasket, cover, press-in	853402	1	1	1	1	
Recovery	Float, ball	223370	1	1	1	1	
Recovery	Hose, vacuum	854103	1	1	1	1	
Recovery	Motor, vacuum	855205	1	1	1	1	
Recovery	Foam, noise, vacuum	853305	2	2	2	2	
Recovery	Foam, noise, vacuum, short	853309	1	1	1	1	
Recovery	Hose, squeegee, 90° cuff	854102*	1	1	1	1	
Solution	Hose, sight	859202	3 ft	3 ft	3 ft	3 ft	
Solution	Switch, snap, bent lever	911682	1	1	1	1	
Squeegee Linkage	Bearing, rod end	902051	1	1	1	1	
Squeegee Linkage	Wheel, squeegee	849709*	2	2	2	2	
Squeegee	Blade, rear, 30 in (762 mm) Linatex	850702*	1	1	1	1	
Squeegee	Blade, rear, 30 in (762 mm) urethane	850704*					1
Squeegee	Clamp, over-center, band	852002	2	2	2	2	
Squeegee	Blade, front, 30 in (762 mm) Linatex	850701*	1	1	1	1	
Squeegee	Blade, front, 30 in (762 mm) urethane	850703*					1

\*Indicates wear item

## FRAME ASSEMBLY, S-20 TRACTION/S-24XM

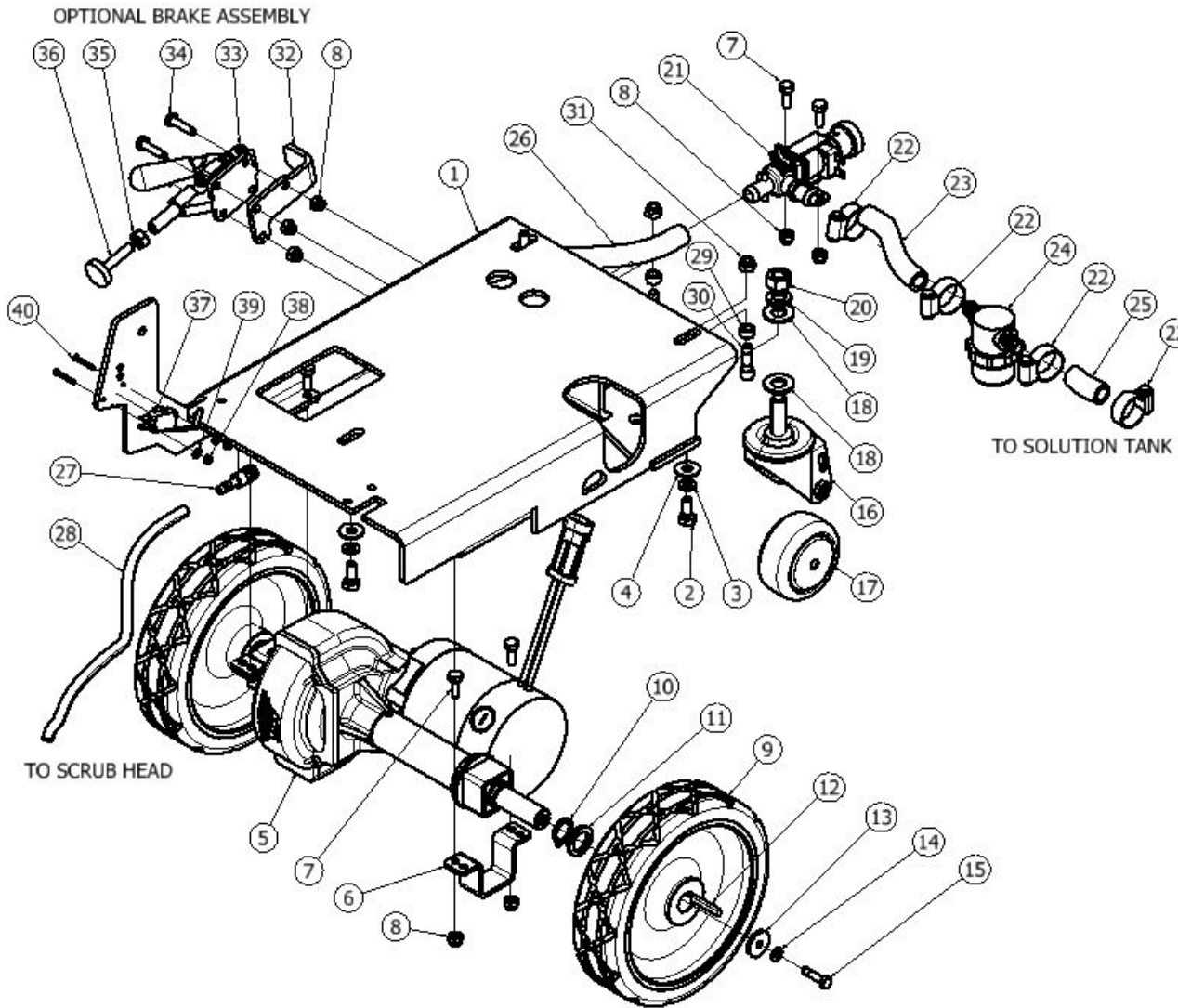

		PARTS LIST	
ITEM	QTY	PART NUMBER	DESCRIPTION
1	1	853202	FRAME, SCRUBBER, 20 TRACT
2	3	962269	SCREW, HEX, .31-18 X .75, SS
3	3	980094	WASHER, SPLIT LOCK, .31, SS
4	3	W243D	WASHER, FLAT, 5/16, SS
5	1	859201	TRANSAXLE, 24VDC, 20 IN
	1	870919	BRUSH KIT REPL FOR TRANSAXLE 859201
	1	855206	MOTOR REPL FOR TRANSAXLE 859201
6	2	850807	BRACKET, RETAINING, TRANS
7	6	W189D	SCREW, HEX, 1/4-20 X .75, SS, PATCH
8	9	920011	NUT, NYLOCK, 1/4-20, ZINC
9	2	859704	WHEEL, TRACTION, 200MM
10	2	847306	RING, RETAINING, EXT, .75
11	2	980780	WASHER, KEYED
12	2	915003	KEY, SQ, .188 X 1.31
13	2	980106	WASHER, FLAT, .25ID, 1.00D, .12THK, SS
14	2	980002	WASHER, LOCK, SPLIT, .25
15	2	964008	SCREW, HEX, M6 X 25, SS, PATCH
16	2	857502	RIG CASTER 3INCH WITH AXLE
17	2	859709	WHEEL CASTER 3INCH
	2	855015	KIT CASTER 3 INCH REPLACEMENT
18	3	980079	WASHER, FLAT, .5, ZINC
19	2	980019	WASHER .50INCH SPLIT LOCK
20	2	920022	NUT HEX .50-13 ZINC
21	1	855014	KIT VALVE SCRUBBER REPLMNT
22	4	S453P	CLAMP, HOSE, WORM
23	1	224130 - 3.75"	HOSE, 1/2" DIA X 3.75" LONG
24	1	843319	FILTER, SCREEN, BOWL
25	1	224130 - 1.56"	HOSE, 1/2" DIA X 1.56" LONG
26	1	224130 - 9.50"	HOSE, 1/2" DIA X 9.50 LONG
27	1	853301	FITTING, REDUCER, BM08, BM04
28	1	204179 - 19.0"	HOSE, 1/4" DIA X 12.50" LONG
29	2	853802	GUIDE, SPACER, ROUND
30	2	962279	SCREW, SOCKET CAP, .31X1.0, SS
31	2	920012	NUT, NYLOCK, 5/16-18, ZINC
32	1	850810	BRACKET, STOP, BRAKE
33	1	852001	CLAMP, BRAKE, OVER-CENTER
34	3	962221	SCREW, HEX, .25-20 X 1.0, SS
35	1	W405D	NUT, HEX, LOCK, .31 - 18
36	1	858401	PAD, STUD, THREADED
37	1	911682	SWITCH, SNAP, BENT LEVER
38	2	W385D	NUT, NYLOCK, #4-40, ZINC
39	2	980682	WASHER, FLAT, #4, ZINC
40	2	962273	SCREW, PAN, #4-40 X .88, ZINC

# FRAME ASSEMBLY, S-20 PAD/BRUSH ASSIST

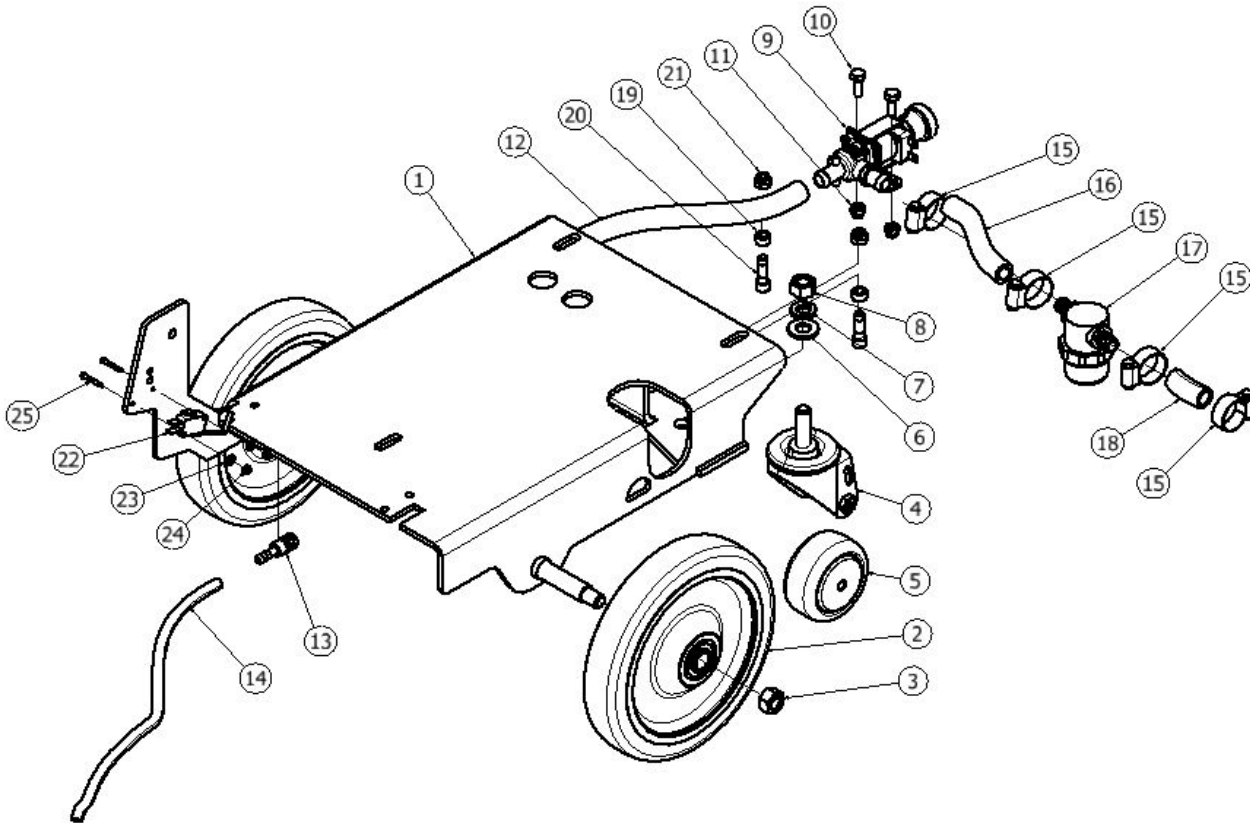

		PARTS LIST	
ITEM	QTY	PART NUMBER	DESCRIPTION
1	1	853201	FRAME, SCRUBBER, 20 BA
2	2	859702	WHEEL, BRG, 8 INCH
3	2	W502D	NUT, NYLOCK, 1/2-13, THIN, ZINC
4	2	857502	RIG CASTER 3INCH WITH AXLE
5	2	859709	WHEEL CASTER 3INCH
	2	855015	KIT CASTER 3 INCH REPLACEMENT
6	2	980079	WASHER, FLAT, .5, ZINC
7	2	980019	WASHER .50INCH SPLIT LOCK
8	2	920022	NUT HEX .50-13 ZINC
9	1	855014	KIT VALVE SCRUBBER REPLMNT
10	2	W189D	SCREW, HEX, 1/4-20 X .75, SS, PATCH
11	2	920011	NUT, NYLOCK, 1/4-20, ZINC
12	1	224130 - 9.50"	HOSE, 1/2" DIA X 9.50" LONG
13	1	853301	FITTING, REDUCER, BM08, BM04
14	1	204179 - 17.0"	HOSE, 1/4" DIA X 12.50" LONG
15	4	S453P	CLAMP, HOSE, WORM
16	1	224130 - 3.75"	HOSE, 1/2" DIA X 3.75" LONG
17	1	843319	FILTER, SCREEN, BOWL
18	1	224130 - 1.56"	HOSE, 1/2" DIA X 1.56" LONG
19	2	853802	GUIDE, SPACER, ROUND
20	2	962279	SCREW, SOCKET CAP, .31X1.0, SS
21	2	920012	NUT, NYLOCK, 5/16-18, ZINC
22	1	911682	SWITCH, SNAP, BENT LEVER
23	2	980682	WASHER, FLAT, #4, ZINC
24	2	W385D	NUT, NYLOCK, #4-40, ZINC
25	2	962273	SCREW, PAN, #4-40 X .88, ZINC

# SOLUTION TANK ASSEMBLY

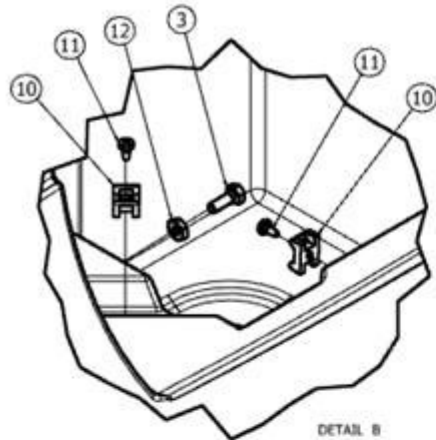

DETAIL B

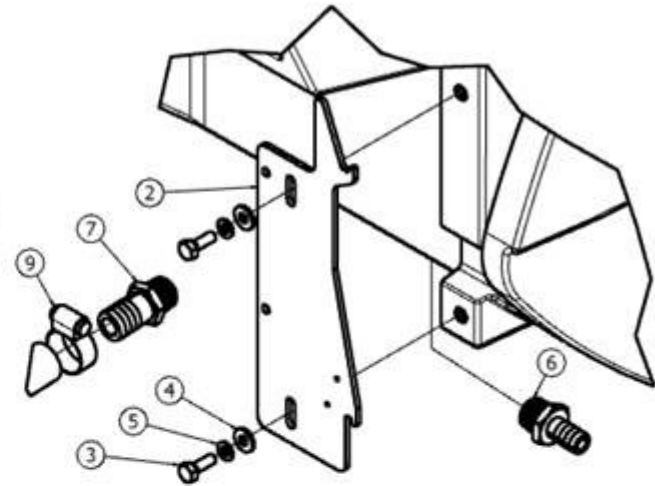
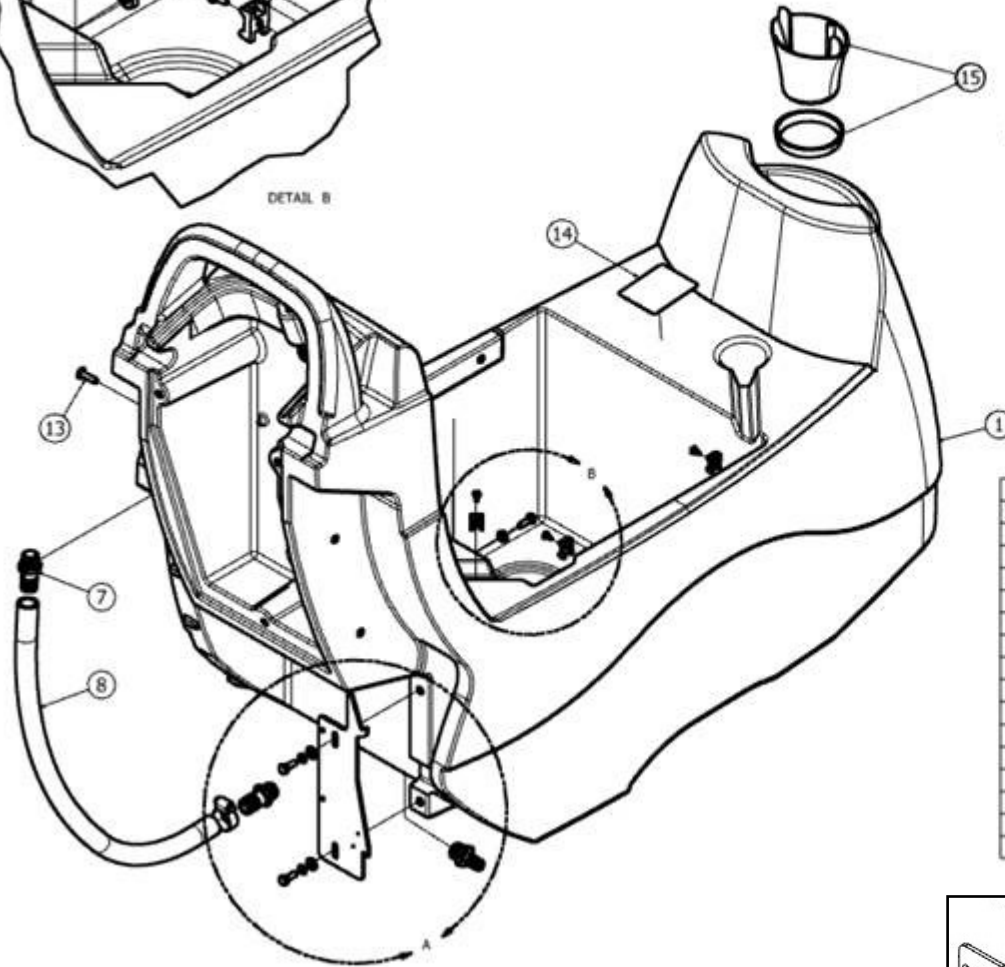

DETAIL A

PARTS LIST			
ITEM	QTY	PART NUMBER	DESCRIPTION
1	1	858601	TANK, SOLUTION, 11 GAL
2	1	850814	BRACKET, SUPPORT, LEVER
3	3	W189D	SCREW, HEX, 1/4-20 X .75, SS, PATCH
4	2	W104D	WASHER, FLAT, .25
5	2	980002	WASHER, LOCK, SPLIT, .25
6	1	223343	FITTING, STR, BM08, PM08
7	2	853303	FITTING, STR, BM12, PM08
8	1	859003	TUBE, SIGHT, REPLACEMENT
9	1	S453P	CLAMP, HOSE, WORM
10	4	225670	PAD, WIRE TIE
11	4	962271	SCREW, PAN, #10 X .38L, ZINC, SELF-TAPPING
12	1	920037	NUT, THIN JAM, 1/4-20, ZINC
13	1	962455	SCREW, TRUSS, .25-20 X 1.0
14	1	855108	LABEL, INSTRUCTION, BATTERY
15	1	875011	KIT, STRAINER, PORT, FILL

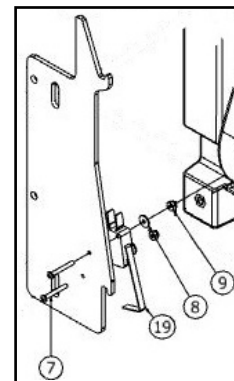

**Head switch location for all machines built prior to April 17, 2015 and before serial #102374**

PARTS LIST			
ITEM	QTY	PART NUMBER	DESCRIPTION
7	2	962273	SCREW, PAN, #4-40 X .88, ZINC
8	2	980682	WASHER, FLAT, #4, ZINC
9	2	W385D	NUT, NYLOCK, #4-40, ZINC
19	1	911682	SWITCH, SNAP, BENT LEVER



# BATTERY ASSEMBLY

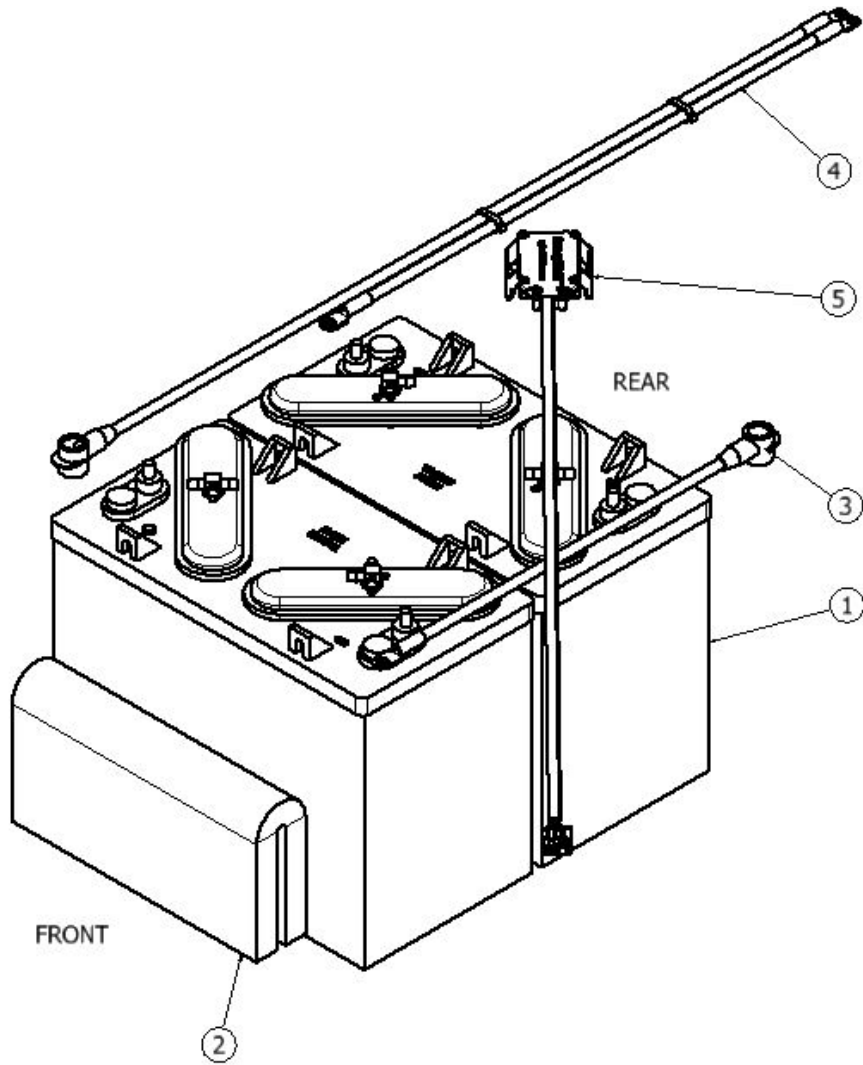

PARTS LIST			
ITEM	QTY	PART NUMBER	DESCRIPTION
1	2	851303	BATTERY, 12V, 155AH, LEAD ACID
1	2	841311	BATTERY, 12V, 140AH, AGM
1	2	881350	BATTERY, 12V, 130AH, LEAD ACID
1	2	851302	BATTERY, 12V, 105AH, AGM
2	1	858202	FOAM, SPACER, BATTERY
3	1	911640	HARNESS, CONN, BATTERY (ALL OTHER MACHINES)
3	1	911683	HARNESS, CONN, BATTERY (PAD ASSIST LEAD ACID)
4	1	911641	HARNESS, BATT-MACHINE (ALL OTHER MACHINES)
4	1	911671	HARNESS, BATT-MACHINE (PAD ASSIST LEAD ACID)
5	1	878520	SENSOR ASSY BATTERYSHIELD FIELD REPLACEMENT
6	1	879002	TUBE & PUMP ASSY (NOT SHOWN, OPTIONAL)

# RECOVERY TANK ASSEMBLY

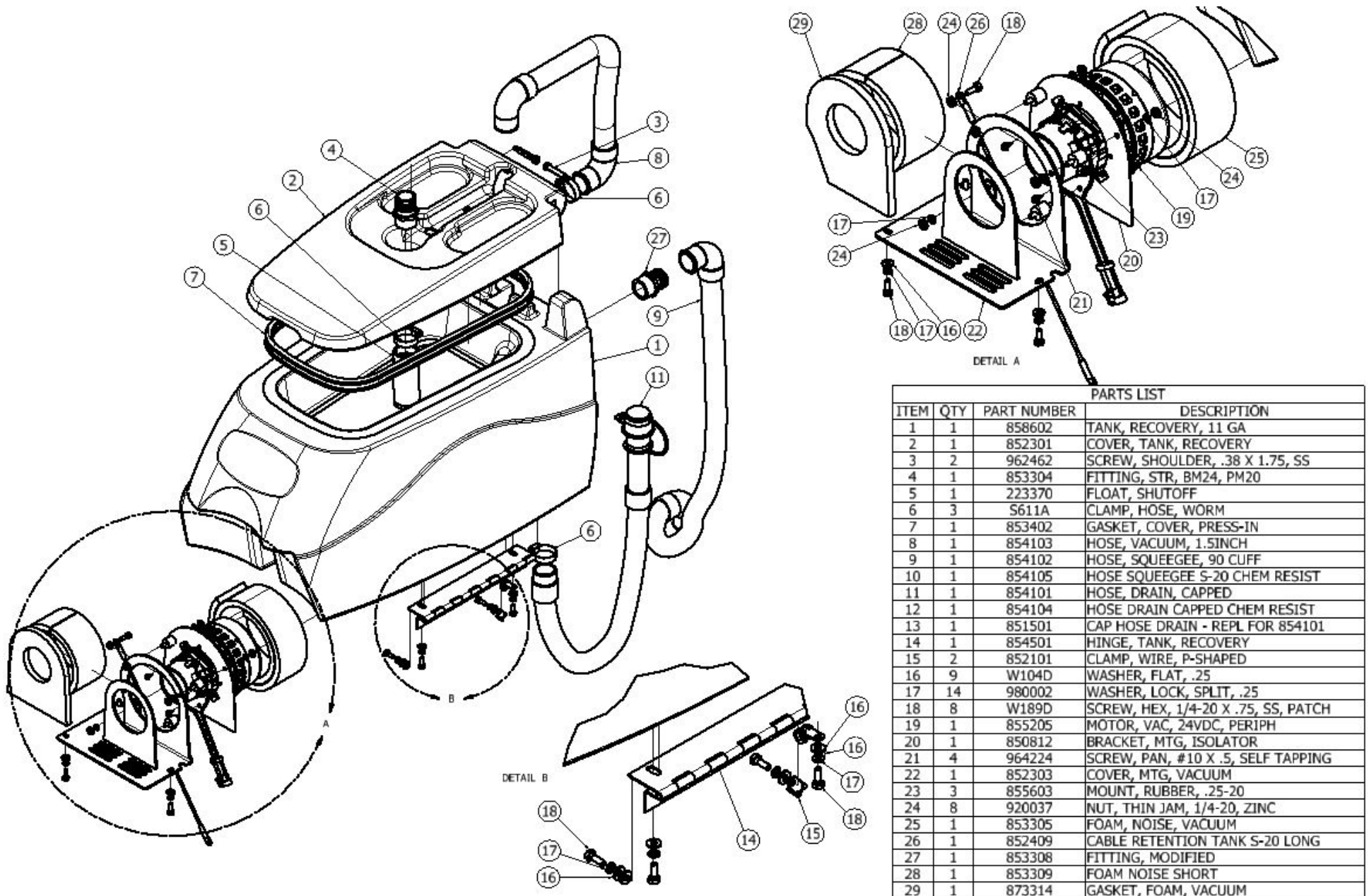

PARTS LIST			
ITEM	QTY	PART NUMBER	DESCRIPTION
1	1	858602	TANK, RECOVERY, 11 GA
2	1	852301	COVER, TANK, RECOVERY
3	2	962462	SCREW, SHOULDER, .38 X 1.75, SS
4	1	853304	FITTING, STR, BM24, PM20
5	1	223370	FLOAT, SHUTOFF
6	3	S611A	CLAMP, HOSE, WORM
7	1	853402	GASKET, COVER, PRESS-IN
8	1	854103	HOSE, VACUUM, 1.5INCH
9	1	854102	HOSE, SQUEEGEE, 90 CUFF
10	1	854105	HOSE SQUEEGEE S-20 CHEM RESIST
11	1	854101	HOSE, DRAIN, CAPPED
12	1	854104	HOSE DRAIN CAPPED CHEM RESIST
13	1	851501	CAP HOSE DRAIN - REPL FOR 854101
14	1	854501	HINGE, TANK, RECOVERY
15	2	852101	CLAMP, WIRE, P-SHAPED
16	9	W104D	WASHER, FLAT, .25
17	14	980002	WASHER, LOCK, SPLIT, .25
18	8	W189D	SCREW, HEX, 1/4-20 X .75, SS, PATCH
19	1	855205	MOTOR, VAC, 24VDC, PERIPH
20	1	850812	BRACKET, MTG, ISOLATOR
21	4	964224	SCREW, PAN, #10 X .5, SELF TAPPING
22	1	852303	COVER, MTG, VACUUM
23	3	855603	MOUNT, RUBBER, .25-20
24	8	920037	NUT, THIN JAM, 1/4-20, ZINC
25	1	853305	FOAM, NOISE, VACUUM
26	1	852409	CABLE RETENTION TANK S-20 LONG
27	1	853308	FITTING, MODIFIED
28	1	853309	FOAM NOISE SHORT
29	1	873314	GASKET, FOAM, VACUUM

# SQUEEGEE ASSEMBLY

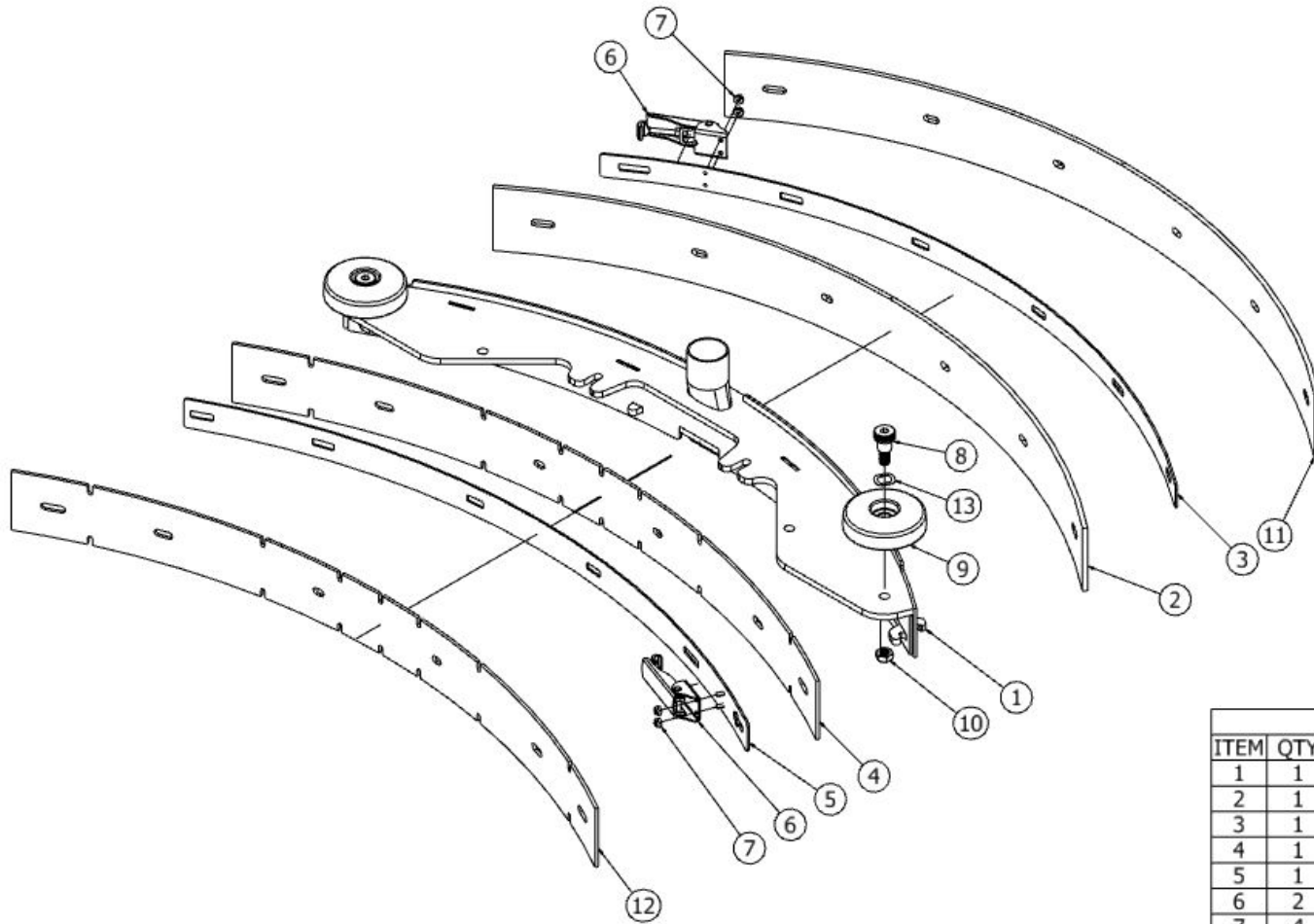

PARTS LIST			
ITEM	QTY	PART NUMBER	DESCRIPTION
1	1	853203	FRAME, SQUEEGEE, 30 INCH
2	1	850702	BLADE, REAR, 30 INCH
3	1	857201	RETAINER, REAR, 30 INCH
4	1	850701	BLADE, FRONT, 30 INCH
5	1	857202	RETAINER, FRONT, 30 INCH
6	2	852002	CLAMP, OVER-CENTER, BAND
7	4	920034	NUT, NYLOCK, #6-32, SS
8	2	962465	SCREW, SHOULDER, .50 X .50
9	2	859703	WHEEL, GUIDE
10	2	920035	NUT, NYLOCK, .38-16, SS
11	1	850704	BLADE, REAR, 30 IN, URETH (OPTIONAL)
12	1	850703	BLADE, FRONT, 30 INCH, URETH (OPTL)
13	2	980093	WASHER, WAVE, .50INCH

## SQUEEGEE LINKAGE ASSEMBLY

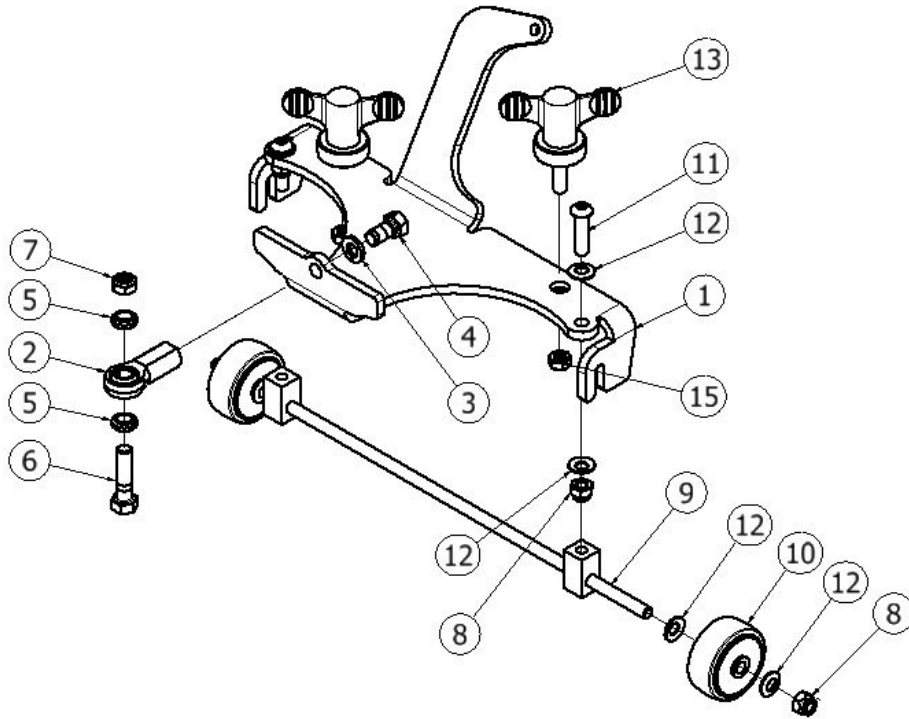

PARTS LIST			
ITEM	QTY	PART NUMBER	DESCRIPTION
1	1	850816	BRACKET LINK SQUEEGEE S-20
2	1	902051	BEARING, ROD END, .38 FEM
3	1	980009	WASHER, SPLIT LOCK, 3/8, SS
4	1	962028	SCREW, HX, .38-24X.75,SS,PTCH
5	2	858204	SPACER, LINK, SQUEEGEE
6	1	962075	SCREW, HEX, 3/8-16 X 1.5, SS
7	1	920035	NUT, NYLOCK, .38-16, SS
8	4	920036	NUT, NYLOCK, 5/16-18, SS
9	1	850501	AXLE, WHEEL, SQUEEGEE
10	2	849709	WHEEL, 2 OD, .31 ID
11	2	962464	SCREW, BUTTON, .31-18X1.25, ZINC
12	8	980105	WASHER, PLASTIC, THRUST
13	2	545010	KNOB KIT WEIGHT RETENTION
15	2	920040	NUT, .31-18, NYLOCK, SS, LOW

# HEAD LIFT ASSEMBLY, DISK

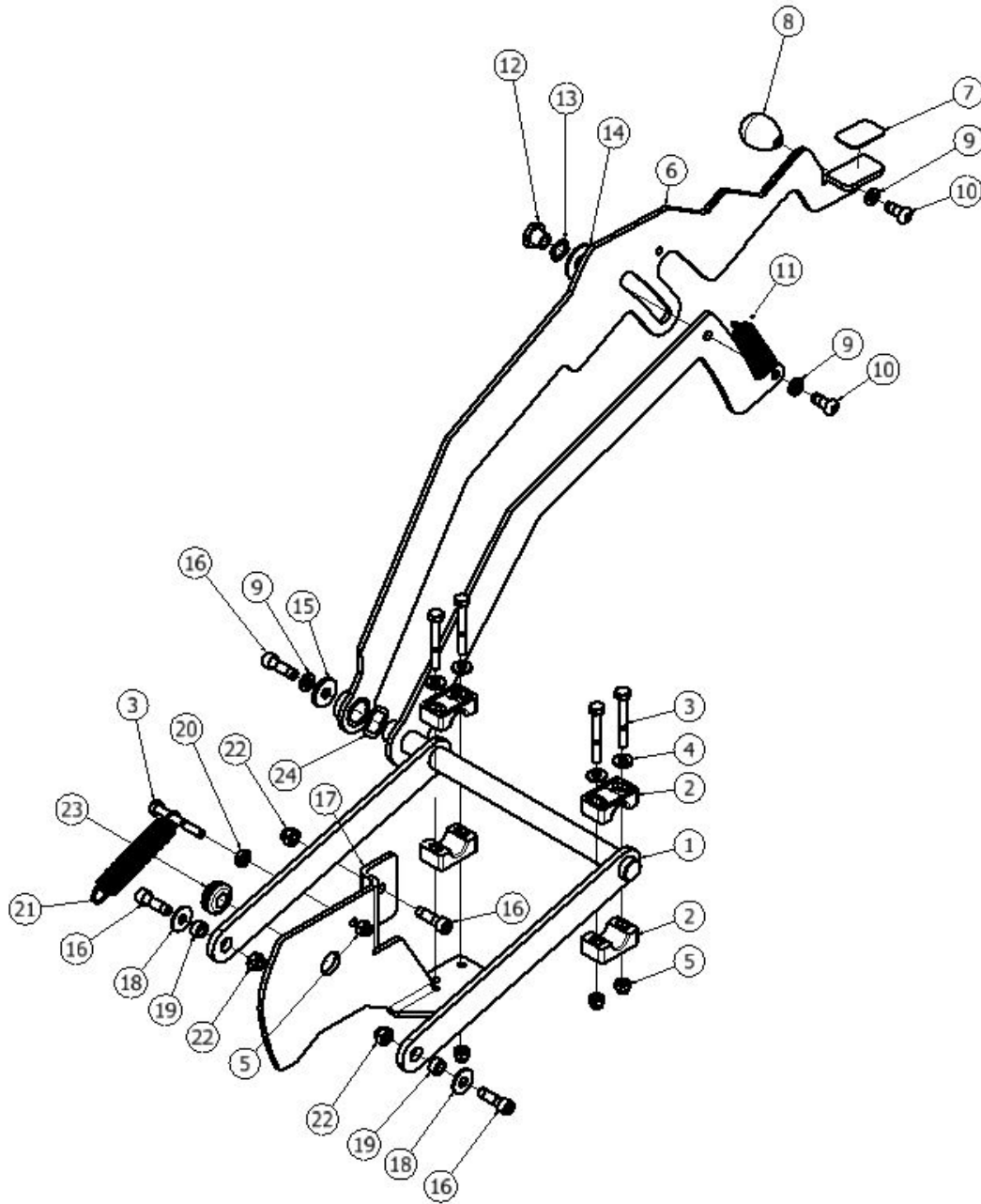

PARTS LIST			
ITEM	QTY	PART NUMBER	DESCRIPTION
1	1	850802	BRACKET, LIFT, HEAD
2	4	855601	MOUNT, BEARING, PLASTIC
3	5	W117D	SCREW, HEX, .25-20 X 2.0, SS
4	4	W104D	WASHER, FLAT, .25
5	5	920011	NUT, NYLOCK, 1/4-20, ZINC
6	1	855105	LEVER, DOWNPRESSURE, DUAL
7	1	855103	LABEL, GRIP, FOOT
8	1	855004	KNOB, OVAL, .31-18
9	3	980094	WASHER, SPLIT LOCK, .31, SS
10	2	962265	SCREW, BUTTON, SOCKET, .31-18 X .75, SS
11	1	858303	SPRING, EXTENSION
12	1	853801	GUIDE, LEVER
13	1	980093	WASHER, WAVE, .50INCH
14	2	980612	WASHER, NYL, .50 X 1.25 X .062
15	1	980107	WASHER, FLAT, .31ID, 1.00D, .12THK, SS
16	4	962279	SCREW, SOCKET CAP, .31X1.0, SS
17	1	850811	BRACKET, GUIDE, HEAD
18	2	W243D	WASHER, FLAT, 5/16, SS
19	2	853802	GUIDE, SPACER, ROUND
20	1	920037	NUT, THIN JAM, 1/4-20, ZINC
21	1	858304	SPRING, EXTENSION
22	3	920012	NUT, NYLOCK, 5/16-18, ZINC
23	1	873804	GROMMET .50ID .81HOLE .25THK
24	1	980783	WASHER WAVE .75ID

## HEAD LIFT ASSEMBLY, S-20 ORBITAL

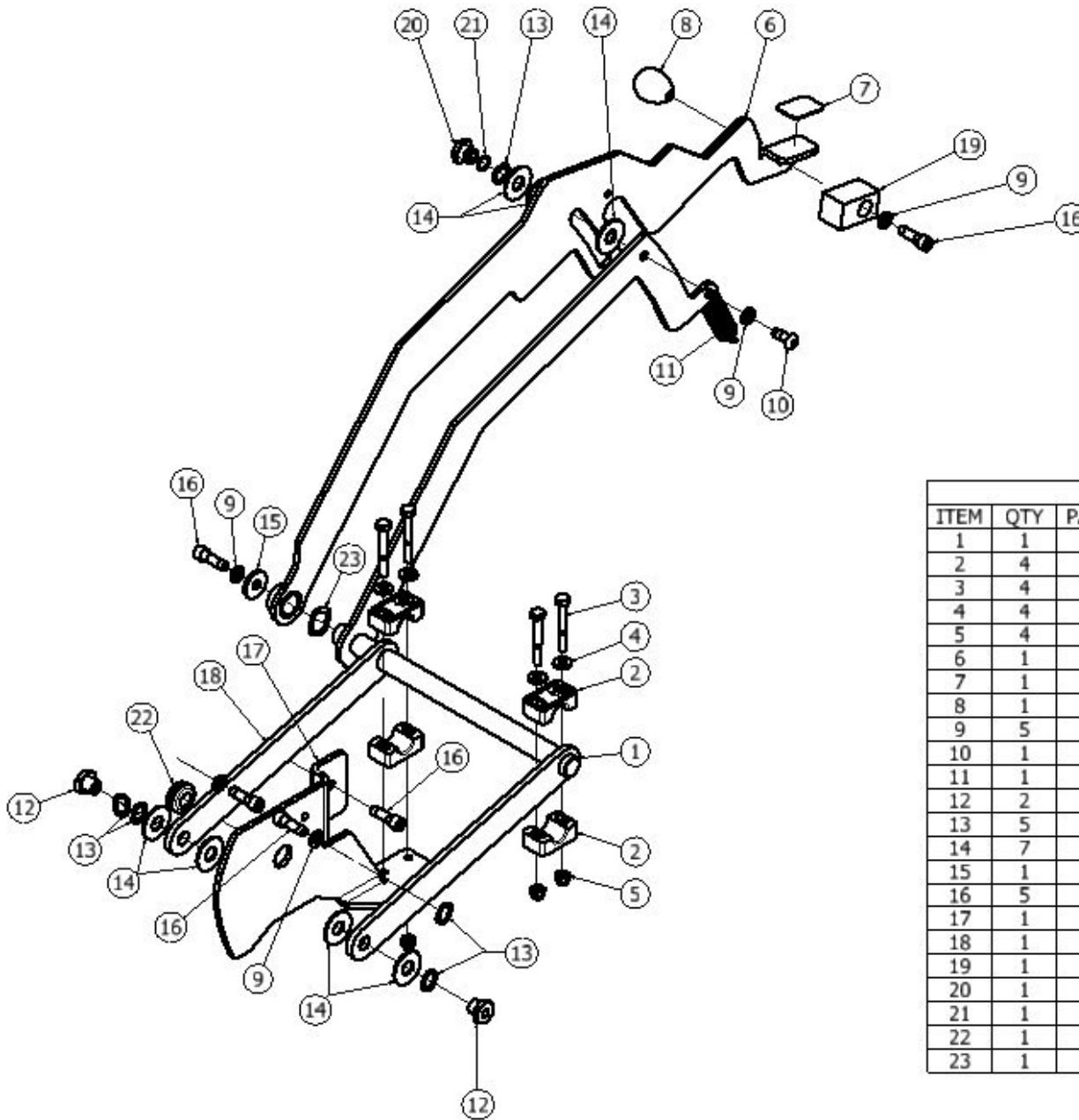

PARTS LIST			
ITEM	QTY	PART NUMBER	DESCRIPTION
1	1	850802	BRACKET, LIFT, HEAD
2	4	855601	MOUNT, BEARING, PLASTIC
3	4	W117D	SCREW, HEX, .25-20 X 2.0, SS
4	4	W104D	WASHER, FLAT, .25
5	4	920011	NUT, NYLOCK, 1/4-20, ZINC
6	1	855105	LEVER, DOWNPRESSURE, DUAL
7	1	855103	LABEL, GRIP, FOOT
8	1	855004	KNOB, OVAL, .31-18
9	5	980094	WASHER, SPLIT LOCK, .31, SS
10	1	962265	SCREW, BUTTON, SOCKET, .31-18 X .75, SS
11	1	858303	SPRING, EXTENSION
12	2	853801	GUIDE, LEVER
13	5	980093	WASHER, WAVE, .50INCH
14	7	980612	WASHER, NYL, .50 X 1.25 X .062
15	1	980107	WASHER, FLAT, .31ID, 1.00D, .12THK, SS
16	5	962279	SCREW, SOCKET CAP, .31X1.0, SS
17	1	850811	BRACKET, GUIDE, HEAD
18	1	920012	NUT, NYLOCK, 5/16-18, ZINC
19	1	851304	BLOCK, WEIGHT, BALANCE
20	1	853805	GUIDE, LEVER, WITH GROOVE
21	1	855801	O-RING, .44X.56X.062
22	1	873804	GROMMET .50ID .81HOLE .25THK
23	1	980783	WASHER WAVE .75ID

# HEAD ASSEMBLY, S-20 DISK

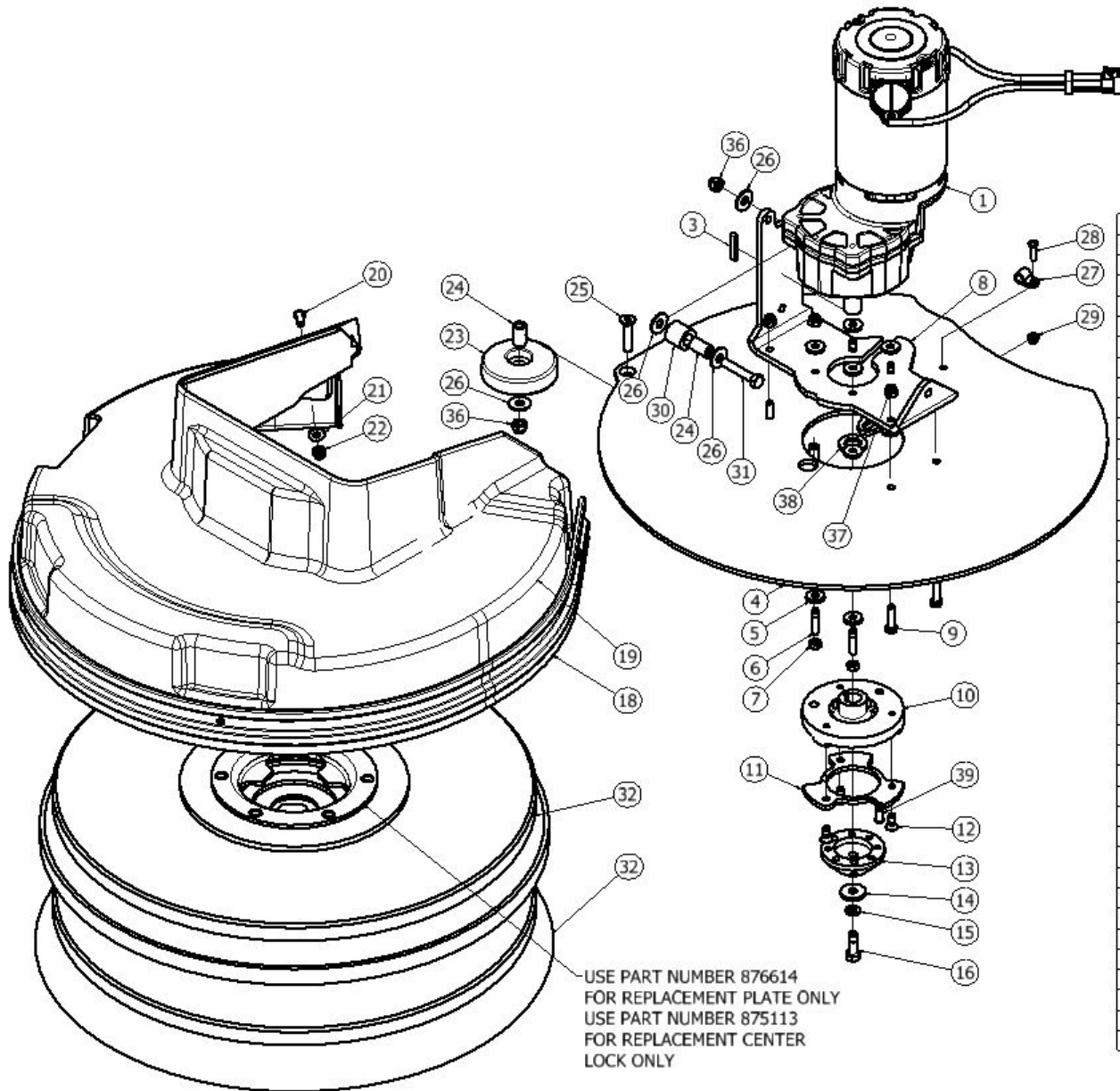

PARTS LIST			
ITEM	QTY	PART NUMBER	DESCRIPTION
1	1	855201	MOTOR, GEAR, BRUSH
2	1	850905	BRUSH CARBON KIT 4 PC 855201
3	1	915005	KEY, SQUARE, 5MM X 1.25
4	1	856602	PLATE, MTG, MOTOR
5	10	980104	WASHER, RUBBER
6	4	964010	SCREW, SET, M6 X 30, SS, PATCH
7	4	924082	NUT, NYLOCK, M6X1.0, SS
8	1	850808	BRACKET, SUPPORT, HEAD
9	4	962221	SCREW, HEX, .25-20 X 1.0, SS
10	1	854302	HUB, DRIVER, BRUSH
11	1	853803	GUIDE, DRIVER
12	3	962274	SCREW, FLAT, SOCK, .25-20X.62, SS, PATCH
13	1	853804	GUIDE, PAD, PLASTIC
14	1	980107	WASHER, FLAT, 31ID, 1.0OD, .12THK, SS
15	1	980094	WASHER, SPLIT LOCK, .31, SS
16	1	962466	SCREW, HEX, M8-1.25 X 25, SS, PATCH
17	1	855016	KIT SHROUD REPLACEMENT (ITEMS 16 - 20)
18	1	858503	SKIRT, BRISTLE
19	1	852302	SHROUD, HEAD, CUTOUT
20	4	962263	SCREW, BUTT, SOCK, .25-20X.62, SS BO
21	8	W104D	WASHER, FLAT, .25
22	4	920665	NUT, NYLOCK, 1/4-20, SS
23	1	859703	WHEEL, GUIDE
24	2	858203	SPACER, WHEEL, GUIDE
25	1	962266	SCREW, FLAT, SOCKET, .31-18 X 1.5, SS
26	4	W243D	WASHER, FLAT, 5/16, SS
27	1	612001	CLAMP, PLASTIC, P-SHAPED
28	1	962003	SCREW, PAN, #10-32 X .75, ZINC
29	1	920666	NUT, NYLOCK, #10-32, SS
30	1	857501	ROLLER, PLASTIC
31	1	962270	SCREW, HEX, 5/16-18X1.75,SS
32	1	855901	DRIVER, PAD, 20INCH, BRISTLE
32	1	850901	BRUSH, POLY, 20 INCH
32	1	850902	BRUSH, NYLON, 20 INCH
32	1	850903	BRUSH, GRIT, 20 INCH
36	2	920012	NUT, NYLOCK, 5/16-18, ZINC
37	4	920011	NUT, NYLOCK, 1/4-20, ZINC
38	1	858201	SPACER, DRIVER, ROUND
39	1	857009	PLUNGER BALL PRESS-IN

## HEAD ASSEMBLY, S-24XM (DRAWING 1 OF 2)

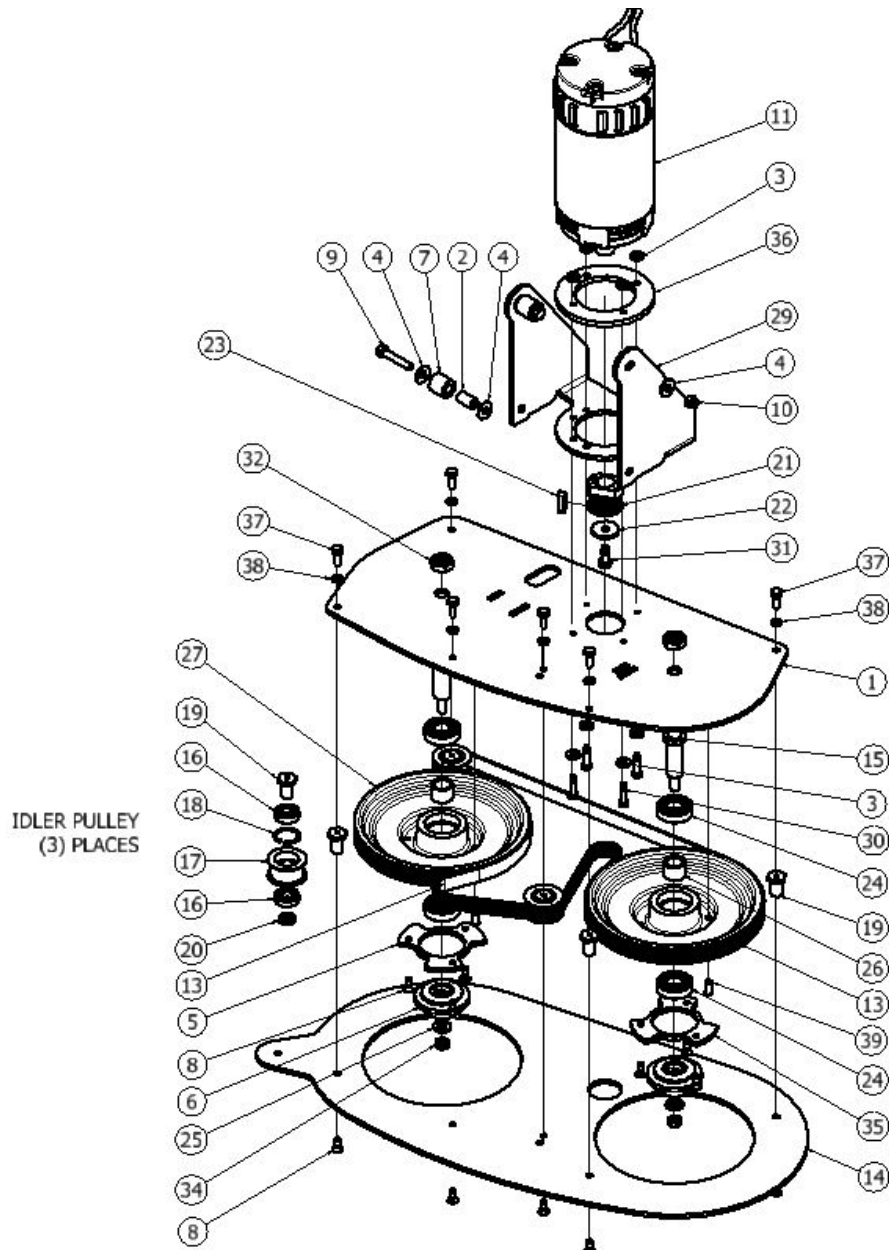

PARTS LIST			
ITEM	QTY	PART NUMBER	DESCRIPTION
1	1	876602	PLATE, MTG, 24 INCH
2	3	858203	SPACER, WHEEL, GUIDE
3	12	W104D	WASHER, FLAT, .25
4	9	W243D	WASHER, FLAT, 5/16, SS
5	1	853803	GUIDE, DRIVER
6	2	873801	GUIDE, PAD, PLASTIC
7	3	857501	ROLLER, PLASTIC
8	13	962274	SCREW, FLAT, SOCK, .25-20X.62, SS, PATCH
9	3	962270	SCREW, HEX, 5/16-18X1.75, SS
10	3	920012	NUT, NYLOCK, 5/16-18, ZINC
11	1	855204	MOTOR, 24V, 2200 RPM, .75HP
12	1	850906	BRUSH CARBON KIT 4 PC 855204 & 875201
13	1	903046	BELT, V-GROOVE, STRETCH
14	1	876606	PLATE, COVER, 24 INCH
15	2	877701	SHAFT, PULLEY, HEAD
16	6	902035	BEARING, .5 ID, 1.1875 OD
17	3	876901	PULLEY, IDLER
18	3	877302	RING, RETAINING, INT, 1.12 DIA
19	6	878201	SPACER, IDLER
20	3	878202	SPACER, IDLER, PLAIN
21	1	876902	PULLEY, MOTOR, DRIVE
22	1	980108	WASHER, FLAT, .31ID, 1.25OD, .12THK, SS
23	1	915006	KEY, 8MM X 7MM X 28MM
24	4	902053	BEARING, .75 ID, DBL SEAL
25	2	980003	WASHER, FLAT, .38
26	2	878203	SPACER, BEARING
27	1	874306	HUB, PULLEY, MACH GROOVED
28	1	874305	HUB, PULLEY, MACH FLAT
29	1	870807	BRACKET, SUPPORT, HEAD 24
30	4	964008	SCREW, HEX, M6 X 25, SS, PATCH
31	1	964060	SCREW, HEX, M8-1.25 X 20, SS
32	2	920039	NUT, .62-18, NYLOCK, LOW
33	1	870814	BRACKET, SUPPORT, 24XM
34	2	920035	NUT, NYLOCK, .38-16, SS
35	1	873802	GUIDE, DRIVER, RH
36	1	878206	SPACER, MOTOR, 24INCH
37	6	W189D	SCREW, HEX, 1/4-20 X .75, SS, PATCH
38	6	980002	WASHER, LOCK, SPLIT, .25
39	2	857009	PLUNGER BALL PRESS-IN



## HEAD ASSEMBLY, S-24XM (DRAWING 2 OF 2)

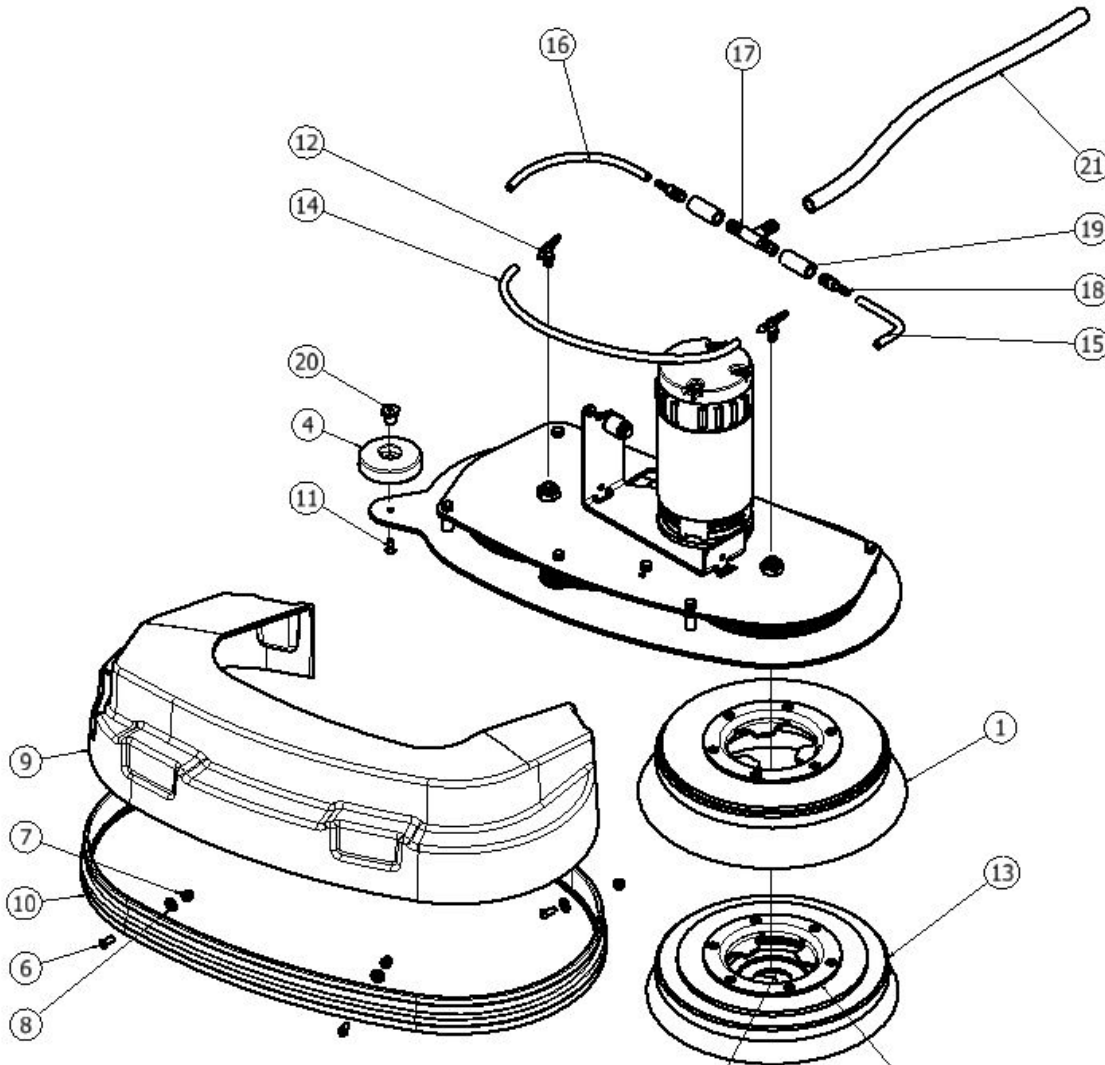

USE PART NUMBER 875113 FOR  
REPLACEMENT CENTER LOCK ONLY

USE PART NUMBER  
876614 FOR REPLACEMENT  
PLATE ONLY

PARTS LIST			
ITEM	QTY	PART NUMBER	DESCRIPTION
1	2	870902	BRUSH, POLY, 12 INCH
1	2	870908	BRUSH, NYLON, 12 INCH
1	2	870909	BRUSH, GRIT, 12 INCH
4	1	859703	WHEEL, GUIDE
	1	875019	KIT SKIRT REPLACEMENT (ITEMS 6 - 10)
6	4	962263	SCREW, BUTT, SOCK, .25-20X.62, SS BO
7	4	920665	NUT, NYLOCK, 1/4-20, SS
8	12	W104D	WASHER, FLAT, .25
9	1	872305	SHROUD, HEAD, 24INCH
10	1	858503	SKIRT, BRISTLE
12	2	873302	FITTING, TEE, PM02XBM04
13	2	875901	DRIVER, PAD, 12INCH, BRISTLE
14	1	204179 - 16.0"	TUBING, 1/4"
15	1	204179 - 9.75"	TUBING, 1/4"
16	1	204179 - 8.25"	TUBING, 1/4"
17	1	873308	FITTING, TEE, 0.50 INCH
18	2	853301	FITTING, REDUCER, BM08, BM04
19	2	224130 - 1.75"	TUBING, 1/2"
20	1	878205	SPACER, WHEEL, GUIDE
21	1	224130 - 20.0"	TUBING, 1/2"
22	2	857009	PLUNGER BALL PRESS-IN

# HEAD ASSEMBLY, UPPER, S-20 ORBITAL

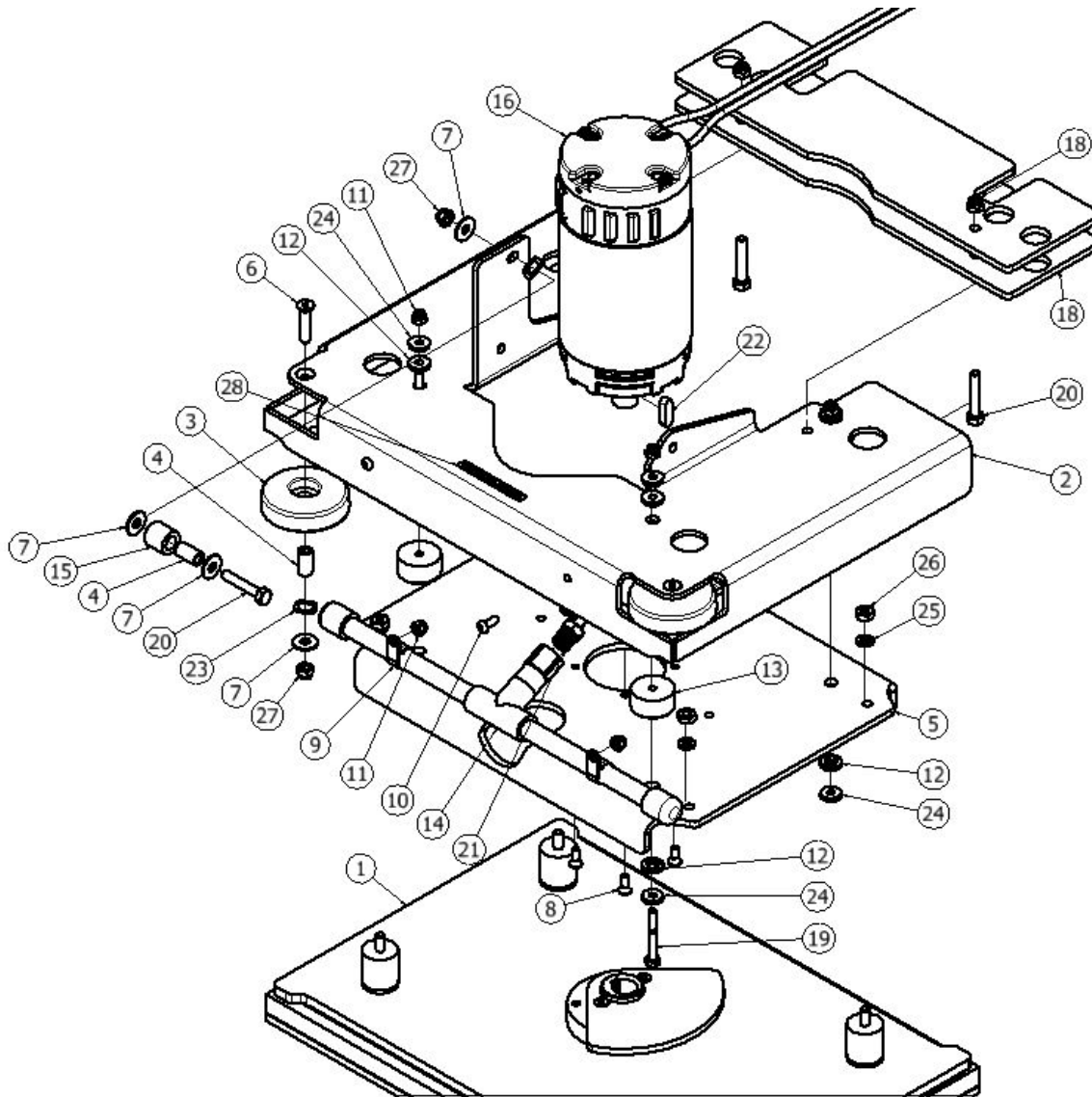

PARTS LIST			
ITE	QTY	PART NUMBER	DESCRIPTION
1	1	NONE	SUB ASSY - HEAD, 20 INCH, ORBITAL
2	1	850813	BRACKET, MTG, HEAD, ORBITAL
3	2	859703	WHEEL, GUIDE
4	3	858203	SPACER, WHEEL, GUIDE
5	1	856603	PLATE, MOUNTING, MOTOR
6	2	962266	SCREW, FLAT, SOCKET, .31-18 X 1.5, SS
7	5	W243D	WASHER, FLAT, 5/16, SS
8	4	964009	SCREW, SCK, FLT, M6-1 X 20, SS, PATCH
9	2	852003	CLAMP, P-SHAPED, .62 DIA
10	2	962263	SCREW, BUTT, SOCK, .25-20X.62, SS BO
11	6	920665	NUT, NYLOCK, 1/4-20, SS
12	8	851101	BUSHING, RUBBER
13	4	858205	SPACER, RUBBER
14	1	859001	TUBE ASSY, WATER, PVC
15	1	857501	ROLLER, PLASTIC
16	1	855204	MOTOR, 24V, 2200 RPM, .75HP
17	1	850906	BRUSH CARBON KIT 4 PC 855204 & 875201
18	2	856611	PLATE, WEIGHT
19	4	W117D	SCREW, HEX, .25-20 X 2.0, SS
20	3	962270	SCREW, HEX, 5/16-18X1.75,SS
21	1	853307	FITTING, ELBOW, PM06, BM04
22	1	915006	KEY, 8MM X 7MM X 28MM
23	3	980093	WASHER, WAVE, .50INCH
24	8	980104	WASHER, RUBBER
25	4	980094	WASHER, SPLIT LOCK, .31, SS
26	4	W405D	NUT, .31-18, JAM, SS
27	5	920012	NUT, NYLOCK, 5/16-18, ZINC
28	1	855116	LABEL PATENT ORBITAL HEAD

# HEAD ASSEMBLY, LOWER, S-20 ORBITAL

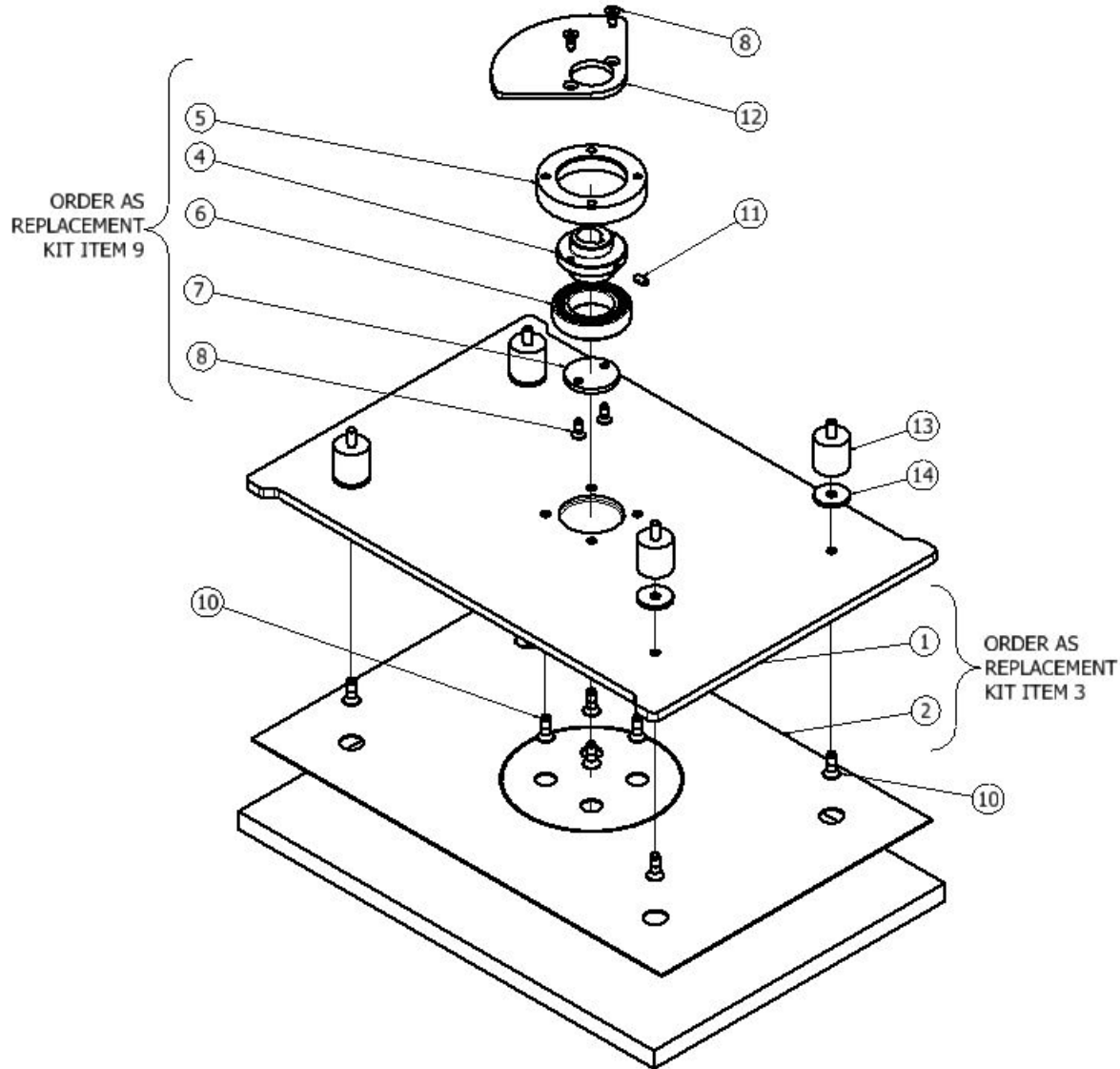

		PARTS LIST	
ITEM	QTY	PART NUMBER	DESCRIPTION
1	1	856604	PLATE, ORBITAL, 20 INCH
2	1	855921	PAD, VELCRO, ADHESIVE
3	1	855011	KIT, PLATE, REPL, ORBIT
4	1		COLLAR, SHAFT, ECCENTRIC
5	1		RING, RETAINER, BEARING
6	1		BEARING, 40MM, SEALED
7	1		PLATE, RETAINER, BEARING
8	4	962274	SCREW, FLAT, SOCK, .25-20X.62, SS, PATCH
9	1	855010	KIT, BEARING, REPLMNT, ORBITAL
10	8	962278	SCREW, SOCKET, FLT, .31-18X.88, SS, PATCH
11	1	962280	SCREW, SET, .25-20X.5, SS, PATCH
12	1	856606	PLATE, BALANCE, 20 INCH
13	4	855604	MOUNT, ISOLATOR, .31THD
14	4	980108	WASHER, FLAT, .31ID, 1.25OD, .12THK, SS
	1	545908	PAD GREEN TURF 14X20
	1	855902	PAD 14X20 SPP DP SCRUB 10/CASE
	1	855904	PAD 14X20 RED CLEAN BUFFR 10/CASE
	1	855905	PAD 14X20 WHITE POLISH 10/CASE
	1	855906	PAD 14X20 DIAM POLISH 5/CASE PURPLE
	1	855908	PAD 14X20 HIPRO STRIP BLK 10/CASE
	1	545904	PAD VELCRO 20INCH ORBITAL(2 pcs)

# CONTROLS ASSEMBLY, S-20 TRACTION & S-24XM

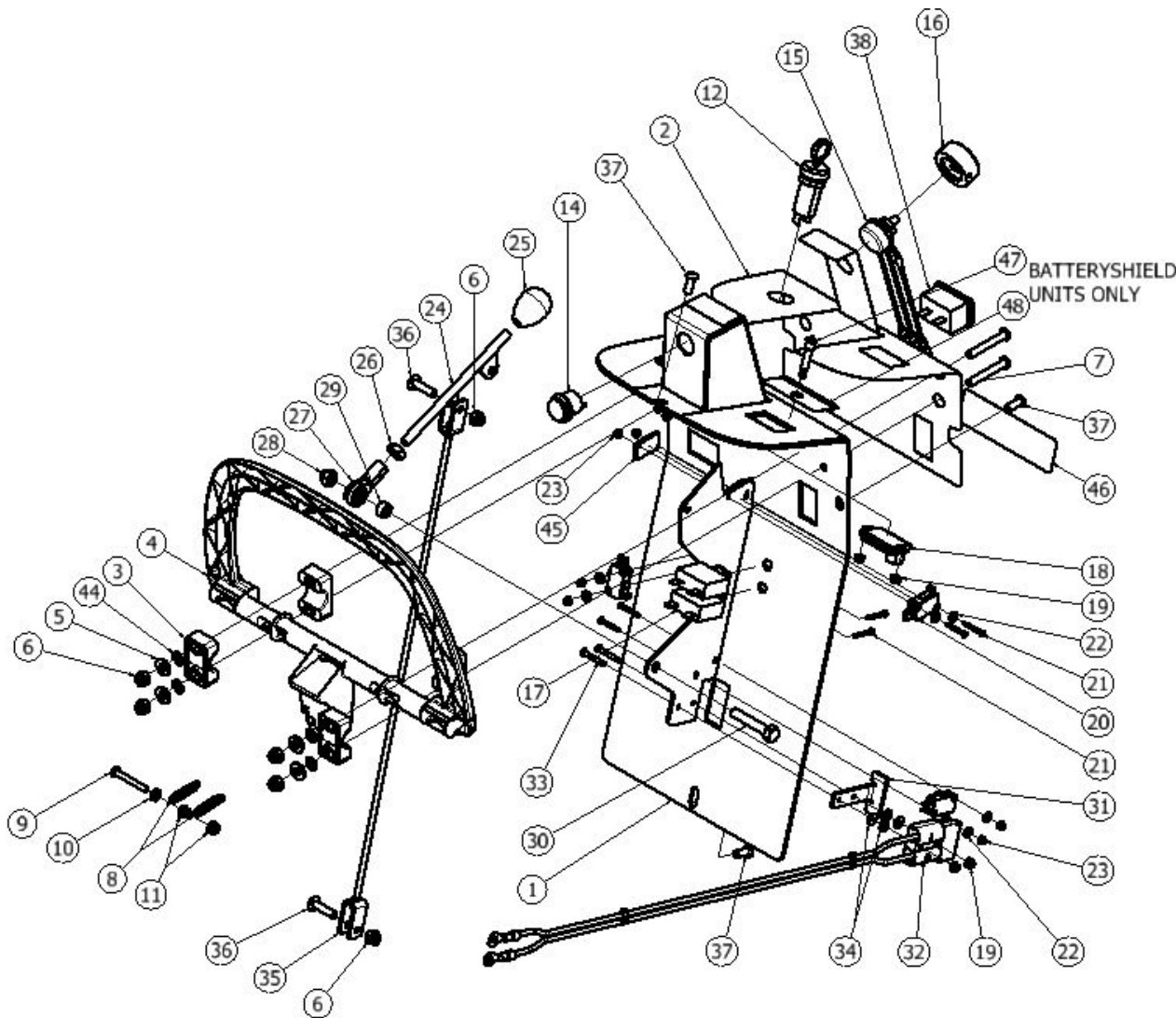

			PARTS LIST
ITEM	QTY	PART NUMBER	DESCRIPTION
1	1	857101	PANEL, CONTROLS
2	1	855102	LABEL, CONTROL, TRACTION
3	4	855601	MOUNT, BEARING, PLASTIC
4	1	851301	BAIL, MOLDED
5	4	W104D	WASHER, FLAT, .25
6	6	920011	NUT, NYLOCK, 1/4-20, ZINC
7	4	962264	SCREW, BUTTON, SOCKET, .25 X 1.75, SS
8	2	858302	SPRING, EXTENSION
9	1	962146	SCREW, PAN, #10-32 X 1.5, FULL, ZINC
10	1	920013	NUT, #10-32, ZINC
11	2	920666	NUT, NYLOCK, #10-32, SS
12	1	911647	SWITCH, KEY
13	1	855012	KEY, REPLACEMENT, SCRUBBER
14	1	911653	SWITCH, ROUND, ON - MOM
15	1	911664	POTENTIOMETER ASSY, 5K
16	1	855001	KNOB, ADJUST, .25 BORE
17	2	911622	CIRCUIT BREAKER, 30 AMPS
18	1	911621	METER, BATTERY
19	4	920034	NUT, NYLOCK, #6-32, SS
20	3	911646	SWITCH, SNAP, WITH ROLLER
21	6	962273	SCREW, PAN, #4-40 X .88, ZINC
22	6	980682	WASHER, FLAT, #4, ZINC
23	6	W385D	NUT, NYLOCK, #4-40, ZINC
24	1	855106	LEVER, LIFT, SQUEEGEE
25	1	855004	KNOB, OVAL, .31-18
26	1	920038	NUT, HEX, .31-24, SS
27	1	902050	BEARING, ROD END, .31-24
28	1	920012	NUT, NYLOCK, 5/16-18, ZINC
29	1	853802	GUIDE, SPACER, ROUND
30	1	962270	SCREW, HEX, 5/16-18X1.75,SS
31	1	850806	BRACKET, PLUG
32	1	911645	HARNESS, CHARGER, POST
33	2	W132D	SCREW, PAN, #6-32 X 1.0, ZINC
34	4	980033	WASHER, FLAT, #6, SS
35	1	852401	CABLE, LIFT, CLEVIS
36	2	962455	SCREW, TRUSS, .25-20 X 1.0
37	4	962263	SCREW, BUTT, SOCK, .25-20X.62, SS BO
38	1	911661	METER, HOUR, DIGITAL (OPTIONAL)
39	1	911643	HARNESS, POWER, TRACTION, S-20
40	1	911670	HARNESS, POWER, ORBITAL, S-20
41	1	911688	HARNESS, POWER, S-24XM
42	1	911667	HARNESS, SIGNAL, DISK, S-20
43	1	911668	HARNESS, SIGNAL, ORBITAL, S-20
44	4	980029	WASHER, LOCK, STAR, EXTERNAL
45	2	856608	PLATE, MOUNTING
46	1	855111	LABEL, QR CODE, S-20
47	2	875107	LED, RED, 24VDC
48	1	855115	LABEL BATTERYSHIELD WITH QR CODE

# CONTROLS ASSEMBLY, S-20 PAD/BRUSH ASSIST

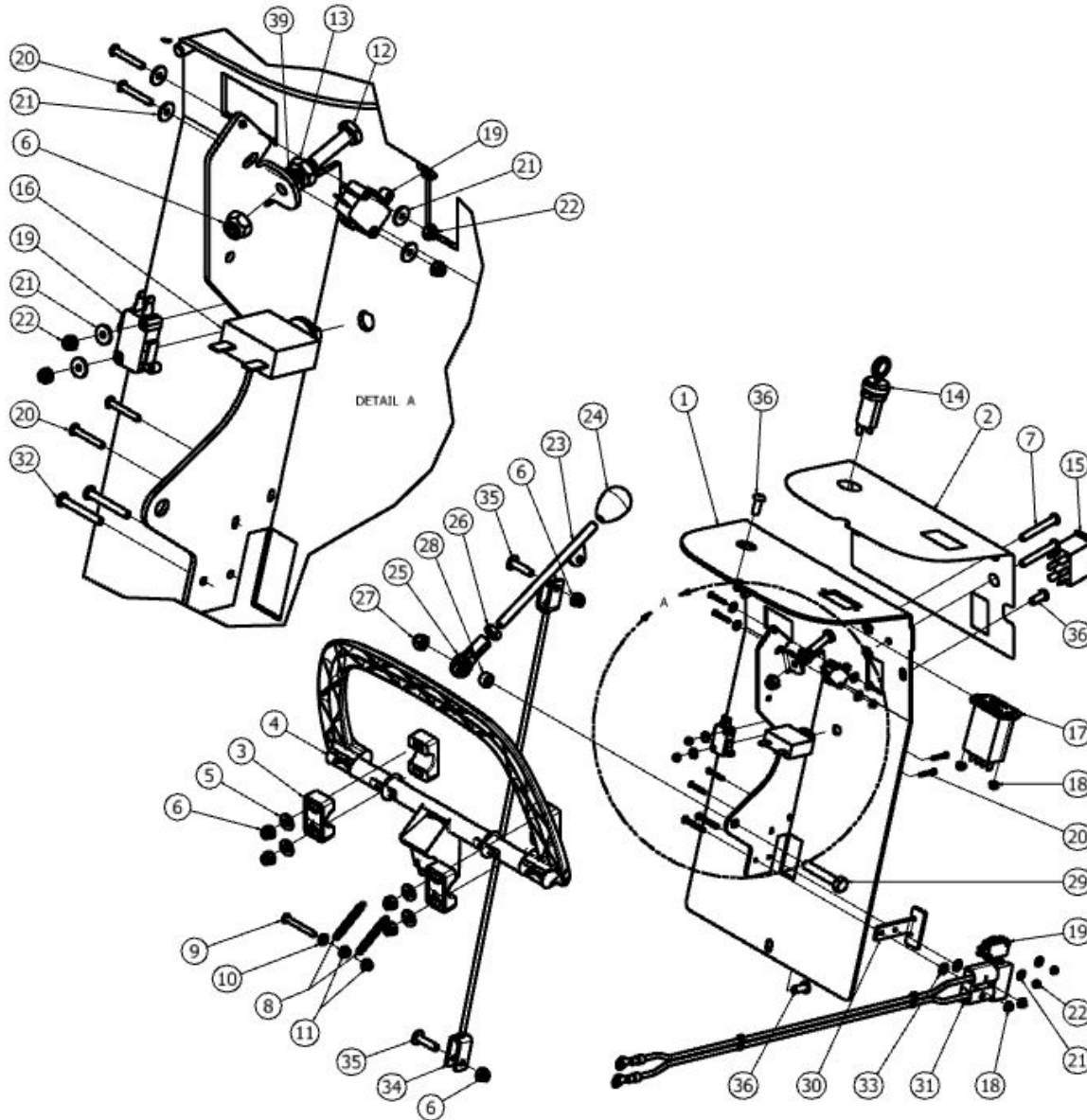

PARTS LIST			
ITEM	QTY	PART NUMBER	DESCRIPTION
1	1	857001	PANEL, CONTROLS
2	1	855101	LABEL, CONTROL, BA
3	4	855601	MOUNT, BEARING, PLASTIC
4	1	851301	BAIL, MOLDED
5	4	W104D	WASHER, FLAT, .25
6	7	920011	NUT, NYLOCK, 1/4-20, ZINC
7	4	962264	SCREW, BUTTON, SOCKET, .25 X 1.75, SS
8	2	858302	SPRING, EXTENSION
9	1	962146	SCREW, PAN, #10-32 X 1.5, FULL, ZINC
10	1	920013	NUT, #10-32, ZINC
11	2	920666	NUT, NYLOCK, #10-32, SS
12	1	962221	SCREW, HEX, .25-20 X 1.0, SS
13	1	920037	NUT, THIN JAM, 1/4-20, ZINC
14	1	911647	SWITCH, KEY
14	1	855012	KEY, REPLACEMENT, SCRUBBER
15	1	911649	SWITCH, ROCKER, AUTO ON-OFF
16	1	911622	CIRCUIT BREAKER, 30 AMPS
17	1	915602	METER, BATTERY
18	4	920034	NUT, NYLOCK, #6-32, SS
19	3	911646	SWITCH, SNAP, WITH ROLLER
20	6	962273	SCREW, PAN, #4-40 X .75, ZINC
21	8	980682	WASHER, FLAT, #4, ZINC
22	6	W385D	NUT, NYLOCK, #4-40, ZINC
23	1	855106	LEVER, LIFT, SQUEEGEE
24	1	855004	KNOB, OVAL, .31-18
25	1	902050	BEARING, ROD END, .31-24
26	1	920038	NUT, HEX, .31-24, SS
27	1	920012	NUT, NYLOCK, 5/16-18, ZINC
28	1	853802	GUIDE, SPACER, ROUND
29	1	962270	SCREW, HEX, 5/16-18X1.75,SS
30	1	850806	BRACKET, PLUG
31	1	911645	HARNESS, CHARGER, POST
32	2	W132D	SCREW, PAN, #6-32 X 1.0, ZINC
33	2	980033	WASHER, FLAT, #6, SS
34	1	852401	CABLE, LIFT, CLEVIS
35	2	962455	SCREW, TRUSS, .25-20 X 1.0
36	4	962263	SCREW, BUTT, SOCK, .25-20X.62, SS BO
37	1	911669	HARNESS, SIGNAL, S-20 PAD ASSIST
38	1	911644	HARNESS, POWER, S-20 PAD ASSIST
39	1	980002	WASHER, LOCK, SPLIT, .25
40	4	980029	WASHER, LOCK, STAR, EXTERNAL

## ELECTRONICS ASSEMBLY, S-20 ORBITAL

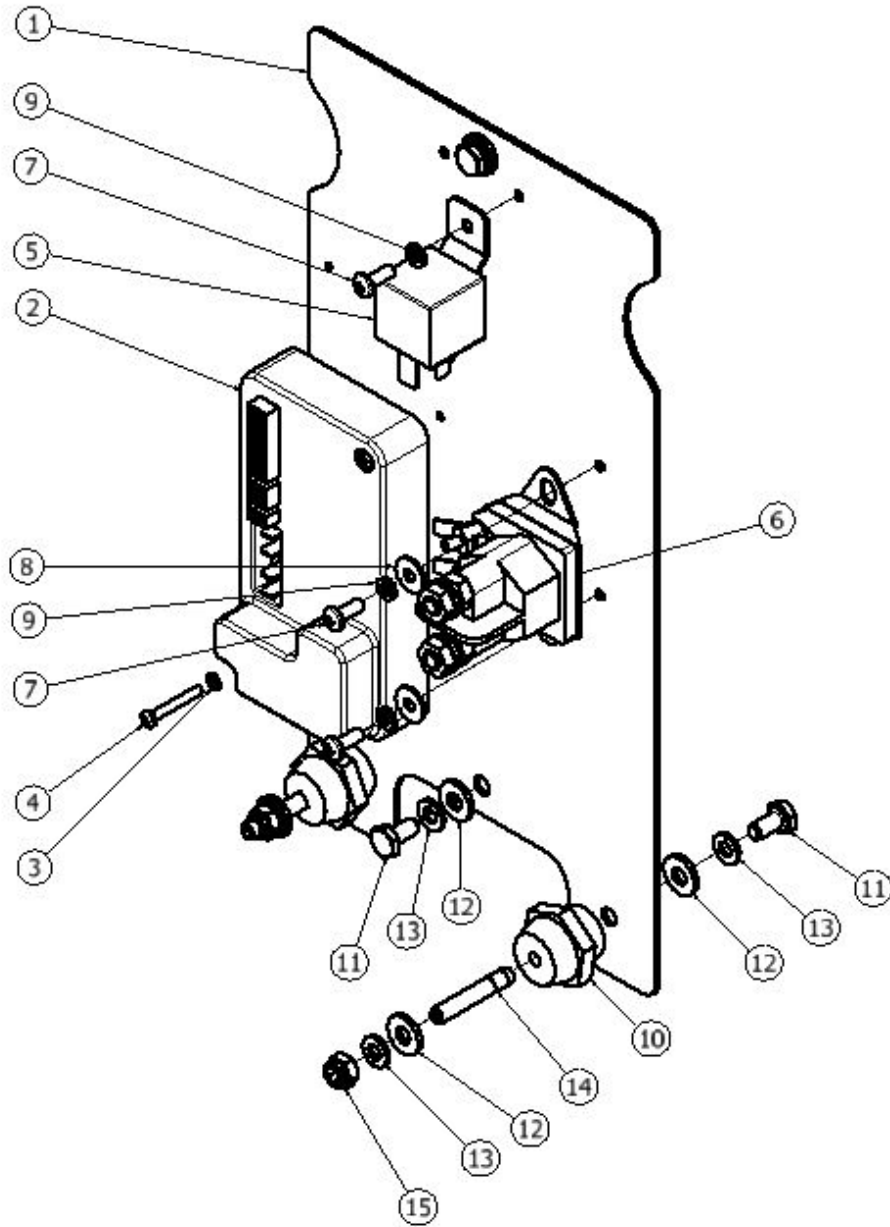

PARTS LIST			
ITEM	QTY	PART NUMBER	DESCRIPTION
1	1	859801	PANEL, ELECTRONICS
2	1	859101	CONTROLLER, TRACTION, S20
3	4	980025	WASHER, SPLIT LOCK, #6, ZINC
4	2	W323D	SCREW, PAN, #6-32 X 1.0, ZINC
5	1	912402	CONTACTOR, 24VDC, 70A
6	1	912401	CONTACTOR, 24V, 100A
7	4	962363	SCREW, PAN, #10-32 X .50, SS
8	2	W401D	WASHER, FLAT, #10
9	4	980022	WASHER, LOCK, SPLIT, #10
10	1	858501	STAND-OFF, INSULATED, .25-20
11	4	W169D	SCREW, HEX, .25-20 X .50
12	5	W104D	WASHER, FLAT, .25
13	6	980002	WASHER, LOCK, SPLIT, .25
14	2	962276	SCREW, SET, .25-20 X 1.25, ZINC, PATCH
15	2	924083	NUT .25-20 FLEX LOCK ZINC

## ELECTRONICS ASSEMBLY, S-20 TRACTION & S-24XM

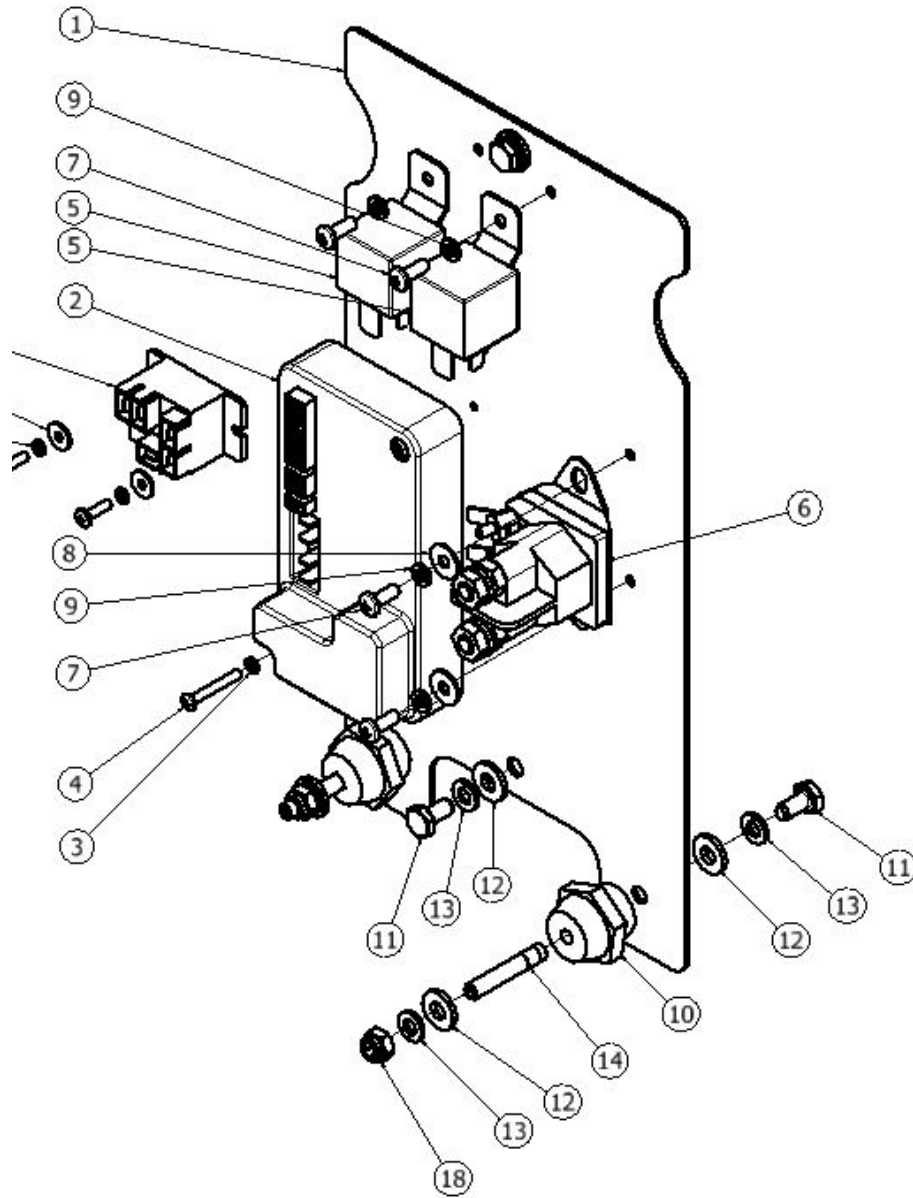

PARTS LIST			
ITEM	QTY	PART NUMBER	DESCRIPTION
1	1	859801	PANEL, ELECTRONICS
2	1	859101	CONTROLLER, TRACTION, S20
3	4	980025	WASHER, SPLIT LOCK, #6, ZINC
4	2	W323D	SCREW, PAN, #6-32 X 1.0, ZINC
5	2	912402	CONTACTOR, 24VDC, 70A
6	1	912401	CONTACTOR, 24V, 100A
7	4	962363	SCREW, PAN, #10-32 X .50, SS
8	2	W401D	WASHER, FLAT, #10
9	4	980022	WASHER, LOCK, SPLIT, #10
10	2	858501	STAND-OFF, INSULATED, .25-20
11	4	W169D	SCREW, HEX, .25-20 X .50
12	6	W104D	WASHER, FLAT, .25
13	6	980002	WASHER, LOCK, SPLIT, .25
14	2	962276	SCREW, SET, .25-20 X 1.25, ZINC, PATCH
15	2	980033	WASHER, FLAT, #6, SS
16	2	W315D	SCREW, PAN, #6-32 X .50, BLK
17	1	911685	RELAY, 24VDC, BATTERYSHIELD
18	2	924083	NUT .25-20 FLEX LOCK ZINC

## ELECTRONICS ASSEMBLY, S-20 PAD/BRUSH ASSIST

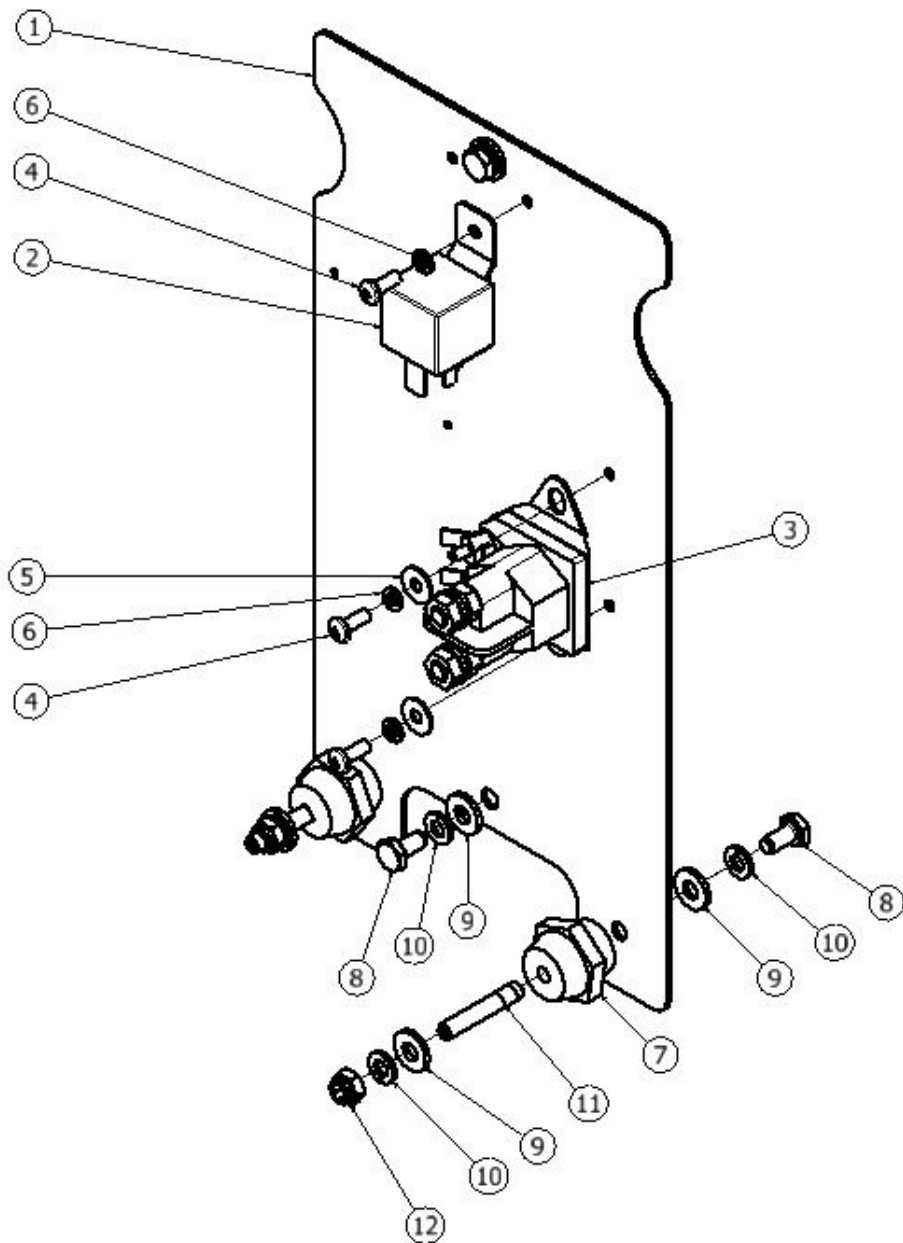

PARTS LIST			
ITEM	QTY	PART NUMBER	DESCRIPTION
1	1	859801	PANEL, ELECTRONICS
2	1	912402	CONTACTOR, 24VDC, 70A
3	1	912401	CONTACTOR, 24V, 100A
4	4	962363	SCREW, PAN, #10-32 X .50, SS
5	2	W401D	WASHER, FLAT, #10
6	4	980022	WASHER, LOCK, SPLIT, #10
7	1	858501	STAND-OFF, INSULATED, .25-20
8	4	W169D	SCREW, HEX, .25-20 X .50
9	5	W104D	WASHER, FLAT, .25
10	6	980002	WASHER, LOCK, SPLIT, .25
11	2	962276	SCREW, SET, .25-20 X 1.25, ZINC, PATCH
12	2	924083	NUT .25-20 FLEX LOCK ZINC



## CHARGER ASSEMBLY, ON-BOARD

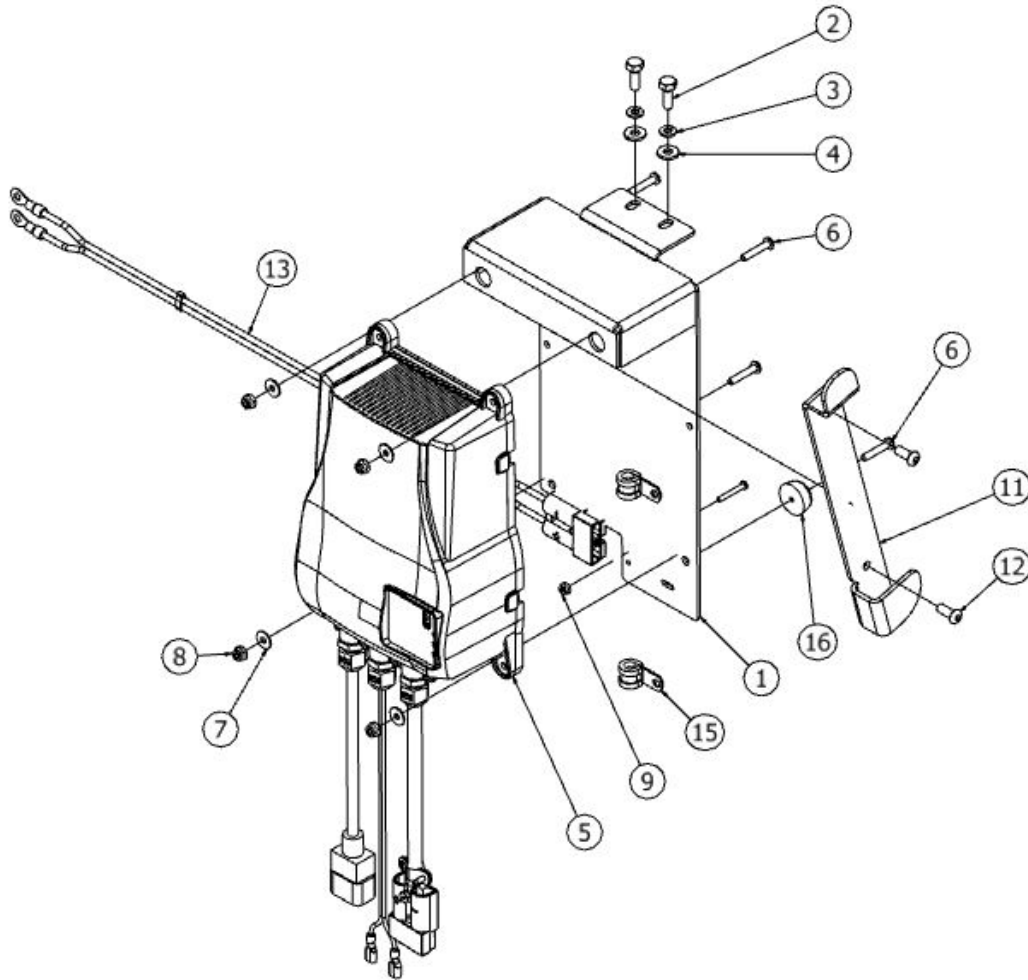

PARTS LIST			
ITEM	QTY	PART NUMBER	DESCRIPTION
1	1	850804	BRACKET, MTG, CHARGER
2	2	W189D	SCREW, HEX, 1/4-20 X .75, SS, PATCH
3	2	980002	WASHER, LOCK, SPLIT, .25
4	2	W104D	WASHER, FLAT, .25
5	1	852407	CHARGER, 24V, ONBRD, CULUS
6	4	962186	SCREW, PAN, #10-32 X 1.0, SS
7	4	W401D	WASHER, FLAT, #10
8	4	920666	NUT, NYLOCK, #10-32, SS
9	1	920034	NUT, NYLOCK, #6-32, SS
10	1	W132D	SCREW, PAN, #6-32 X 1.0, ZINC
11	1	850805	BRACKET, MTG, CORD
12	2	962263	SCREW, BUTT, SOCK, .25-20X.62, SS BO
13	1	911645	HARNES, CHARGER, POST
14	1	908128	CORD, 3M, 3X18SJT, 5-15, IEC C-13
15	2	852101	CLAMP, WIRE, P-SHAPED
16	2	501210	BUMPER

NOT SHOWN

# WIRING DIAGRAM, S-20 TRACTION DRIVE, DISK & S-24XM

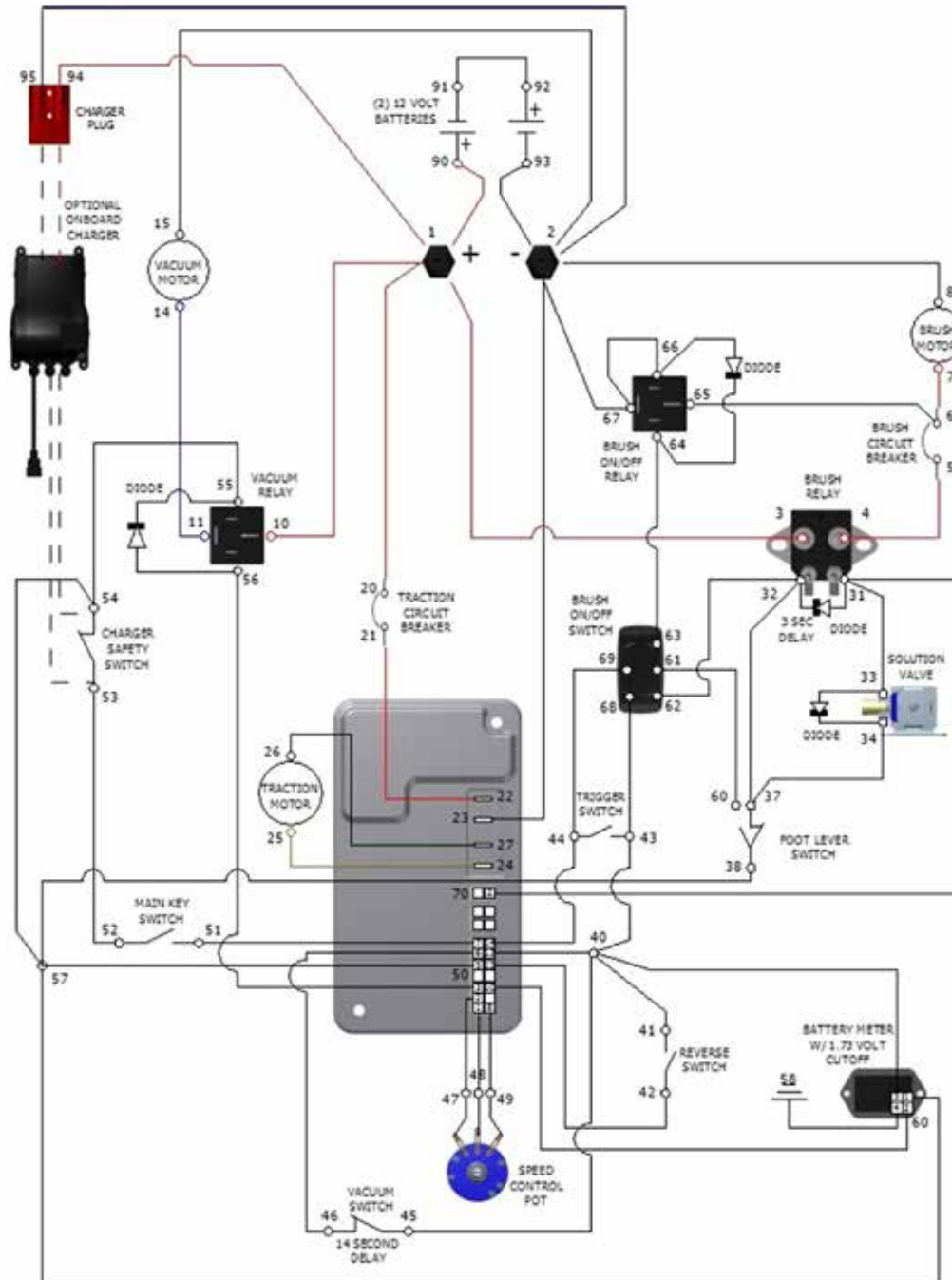

# WIRING DIAGRAM, S-20 PAD/BRUSH ASSIST, DISK

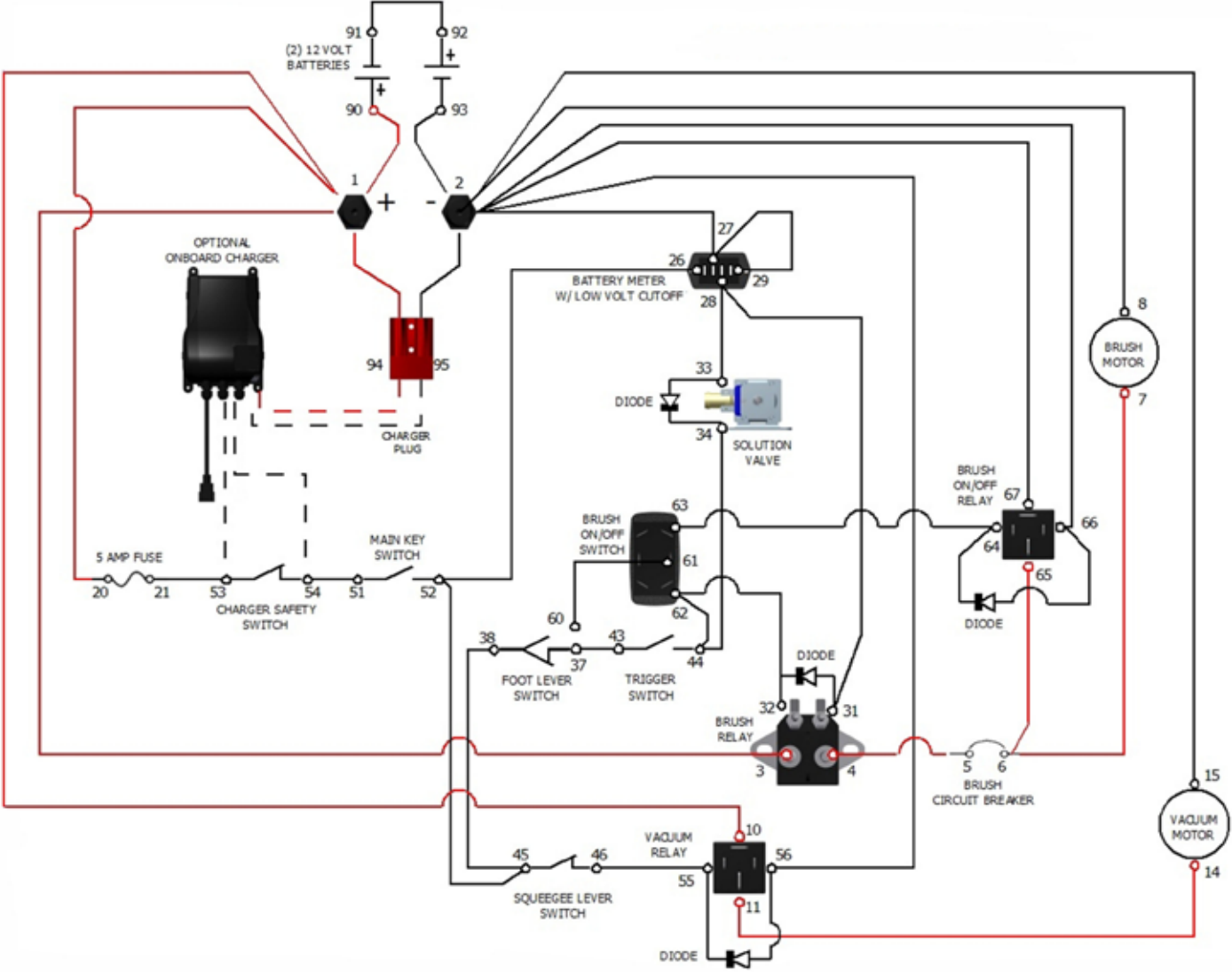

# WIRING DIAGRAM, S-20 ORBITAL

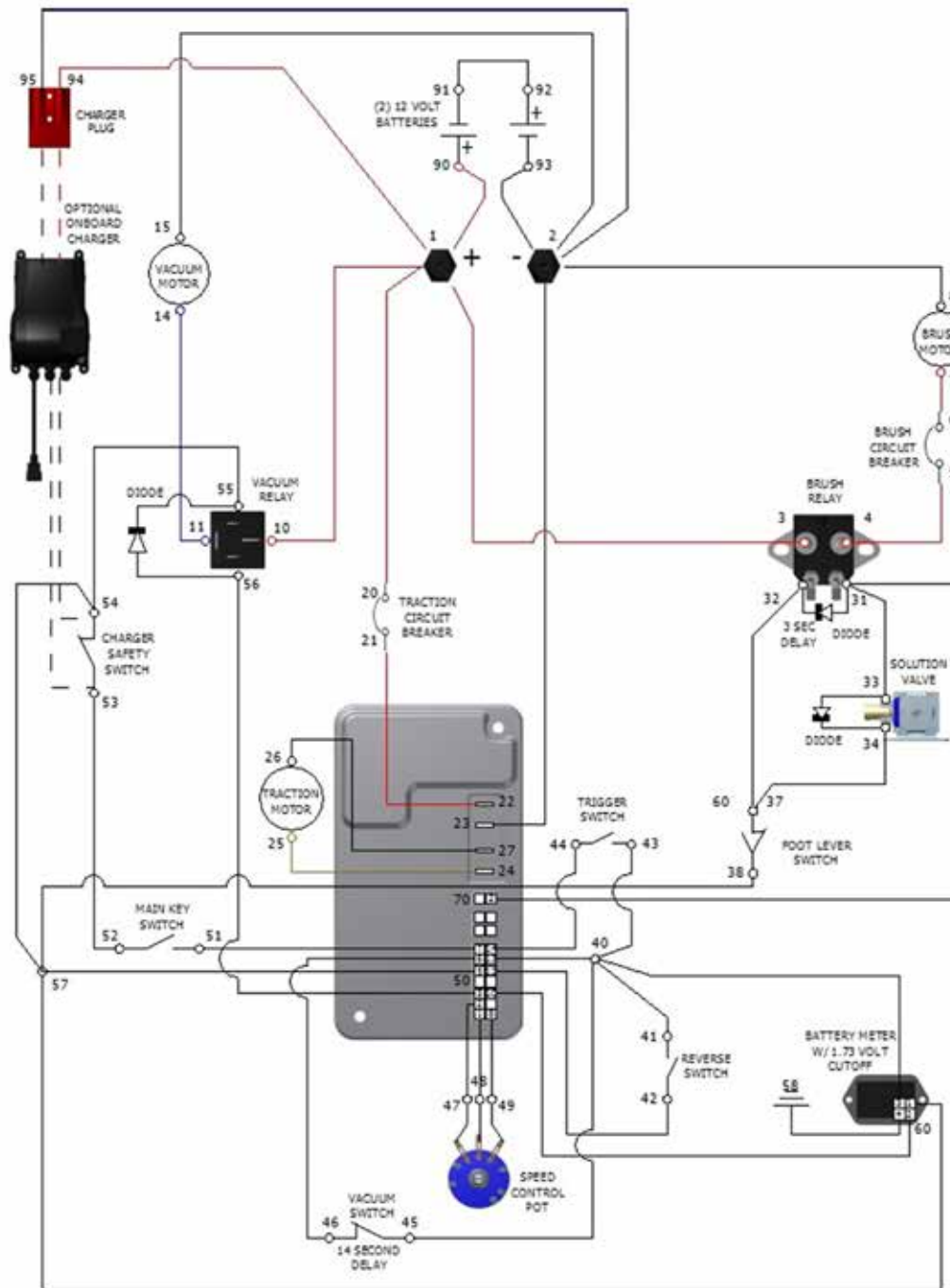

# WIRING DIAGRAM, BATTERYSHIELD™ (OPTIONAL)

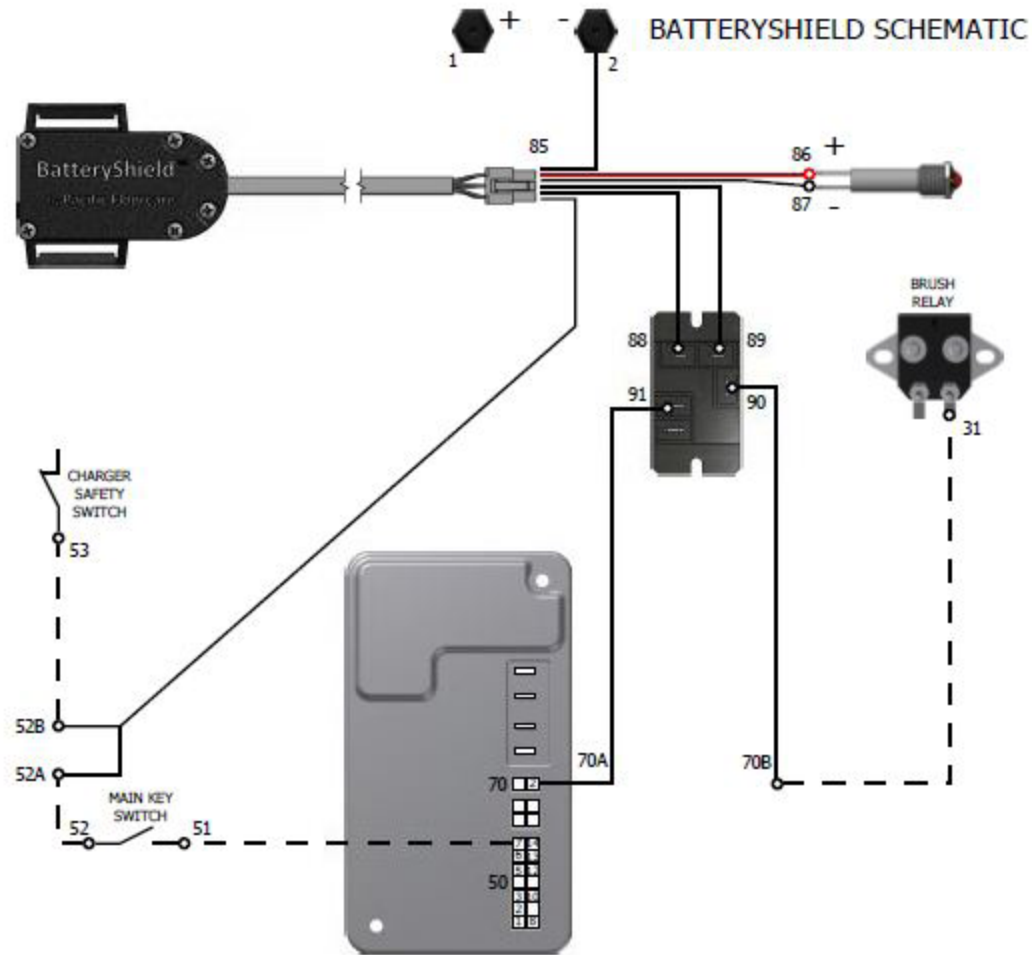

## **WARRANTY POLICY S-20/S-24XM AUTO SCRUBBER**

The Pacific Floorcare S-20 & S-24XM auto scrubbers have been manufactured, tested and inspected in accordance with specific engineering requirements. These machines are warranted to be free from defects in workmanship and materials for periods as follows from the date of purchase.

- Ten (10) Years - Rotationally molded components
- Three (3) Years - Parts (excluding wear items)
- Two (2) Years or 1,200 Hours - Isolators
- One (1) Year - Labor

Travel time for warranty repair is authorized for a period of ninety (90) days following the date of sale to the end user, with a maximum of three (3) hours per claim.

This warranty extends to the original user/purchaser and only when used, operated and maintained in accordance with Pacific Floorcare Operating and Maintenance instructions.

This warranty does not apply to certain wear parts and accessories of the machine such as carbon motor brushes, floor brushes or pad drivers, belts, hoses, squeegee blades, etc., nor does it apply to damage or failure caused by improper use, abuse or neglect. Warranty credit or replacement of return parts including motors, switches, etc., is subject to incoming inspection of those items.

To secure repair under this warranty, the following procedure should be taken:

1. After the expiration of the ninety (90) day travel time warranty period, the customer is responsible for warranty travel payment or the inoperative machine or warranted parts must be delivered to the authorized dealer with shipping and delivery charges prepaid. If unable to locate the Dealer, you may contact Pacific Floorcare at the address listed herein for the location of the nearest Pacific Floorcare repair center or agent or for other instructions pertaining to your warranty difficulty.
2. Upon compliance with the above warranty procedure, all warranted repairs will be completed at no additional charge or cost to the user.
3. Only Pacific Floorcare or its authorized dealers and agents may make no charge warranty repairs on this product. All others do so at their own risk.

This warranty limits Pacific Floorcare liability to the repair of the product and/or warranted parts replacement and does not include incidental or consequential damages arising from the use of a Pacific Floorcare machine whether defective or not.

### **BATTERY WARRANTY**

In addition to the terms above, any original equipment Pacific Floorcare Battery which becomes unserviceable under normal use within a period of ninety (90) days from date of sale to the original user will be repaired or replaced with one of equal specification at our option, F.O.B. any authorized Pacific Floorcare or Service Branch, with no charge to user, except transportation costs. After the expiration of the above ninety (90) day period, any battery which fails under normal use will be adjusted to the original user with a new battery of equal specification on a twelve (12) month pro rata basis from the date of purchase. Adjustment will be determined using the then current list price, plus transportation costs. Warranty is rendered null and void if battery maintenance is not performed regularly.

This warranty is in lieu of all other expressed or implied warranties and is extended to the original purchaser/user.



**PACIFIC**<sup>®</sup>  
F L O O R C A R E

**PURPOSE BUILT.™**

2259 S. SHERIDAN DRIVE  
MUSKEGON, MICHIGAN 49442-6252  
800-968-1332

FAX 800-863-9536