

SCRUBTEC R 466 ...

FOCUS II Micro Rider



Service Manual

Nilfisk Alto, 9087270020 - 9087271020 - 9087272020 - 9087273020

Clarke FOCUS II Micro Rider, 9087278020 - 9087280020

Nilfisk
ALTO
works for you

Clarke®

English

2013-03 Form No. 9098962000

Table of contents

General Information	5
Machine General Description	5
Service Manual Purpose and Field of Application	5
Other Reference Manuals	5
Conventions.	6
Service and Spare Parts	6
Serial Number Decal	6
Safety	7
Symbols	7
General Instructions	7
Machine Lifting.	10
Machine Transportation	10
Machine Nomenclature (know your machine)	11
Control Panel	13
Service and Diagnostic Equipment	14
Technical Data	15
Dimensions	17
Maintenance	19
Scheduled Maintenance Table	19
Chassis System	20
Frame (main parts).	20
Control System	21
Functional Description	21
Wiring Diagram	21
Component Location	22
Function Electronic Board Alarm Codes	23
Display of Current Values of Significant Variables, Hour Counters and Stored Alarms	29
Display and Change of Parameters Which can be Set by the Technician	31
Function Electronic Board Parameters	32
Removal and Installation	34
Specifications	38
Electrical System	43
Functional Description	43
Wiring Diagram	43
Component Location	44
Maintenance	45
Troubleshooting	46
General Wiring Diagram.	47
Specifications	48
Recovery System	49
Functional Description	49
Wiring Diagram	49
Component Location	50
Maintenance and Adjustments	51
Troubleshooting	52
Removal and Installation	53
Specifications	56

Scrub System, Cylindrical	57
Functional Description	57
Wiring Diagram	58
Component Location	59
Maintenance and Adjustments	61
Troubleshooting	63
Removal and Installation	65
Specifications	73
Scrub System, Disc	74
Functional Description	74
Wiring Diagram	75
Component Location	76
Component Location (continued)	77
Maintenance and Adjustments	78
Troubleshooting	79
Removal and Installation	80
Specifications	88
Scrub System, BOOST®	89
Functional Description	89
Wiring Diagram	90
Component Location	91
Component Location (continued)	92
Maintenance and Adjustments	93
Troubleshooting	94
Removal and Installation	95
Specifications	106
Solution System	107
Functional Description	107
Wiring Diagram	107
Component Location	108
Maintenance and Adjustments	109
Troubleshooting	112
Removal and Installation	114
Specifications	116
Squeegee System	117
Functional Description	117
Wiring Diagram	117
Component Location	118
Maintenance and Adjustments	119
Troubleshooting	121
Removal and Installation	122
Specifications	124
Steering System	125
Functional Description	125
Component Location	125
Removal and Installation	126

Wheel System, Driving 128
Functional Description 128
Wiring Diagram 129
Component Location 130
Troubleshooting 131
Removal and Installation 132
Specifications 142

General Information

Machine General Description

The SCRUBTEC R 466 is a “Ride-on” industrial machine designed to wash and dry floors in one pass. The machine is powered by on-board batteries, models can be equipped with Chemical Mixing System (optional). The machine features variable floor pressure disc, cylindrical brushes or BOOST® vibration system , controlled detergent solution dosing and a rear squeegee with rubber blades that vacuums and dries the floor.

Service Manual Purpose and Field of Application

The Service Manual is a technical resource intended to help service technicians when carrying out maintenance and repairs on the SCRUBTEC R 466, to guarantee the best cleaning performance and a long working life for the machine.

Please read this manual carefully before performing any maintenance and repair procedure on the machine.

Other Reference Manuals

Model	Product Code	User Manual	Spare Parts List
Nilfisk Alto SCRUBTEC R 466	9087270020	9098960000	9098961000
Nilfisk Alto SCRUBTEC R 471	9087271020		
Nilfisk Alto SCRUBTEC R 471C	9087272020		
Nilfisk Alto SCRUBTEC BOOST R4	9087273020		
Clarke FOCUS II Micro Rider 26D	9087278020	9099236000	
Clarke FOCUS II Micro Rider 28 BOOST	9087280020		

Assembly Instructions	Instruction Code	Machines concerned
Kit motore aspiratore 24V 670W	9098456000	ALL
Kit Chemical Mixing System	9099118000	ALL
Kit silenziatore cicalino retromarcia	9098773000	ALL

These manuals are available at:

- Local Nilfisk-Alto o Clarke Retailer
- Nilfisk-Alto website: www.nilfisk-alto.com
- Clarke website: www.clarkeus.com

Conventions

Forward, backward, front, rear, left or right are intended with reference to the operator’s position, that is to say in driving position.

Service and Spare Parts



Service and repairs must be performed only by authorised personnel or Nilfisk Service Centers. The authorised personnel is trained directly at the manufacturer's premises and has original spare parts and accessories. Contact Nilfisk Retailer indicated below for service or to order spare parts and accessories, specifying the machine model and serial number.

(Apply Retailer label here)

Serial Number Decal

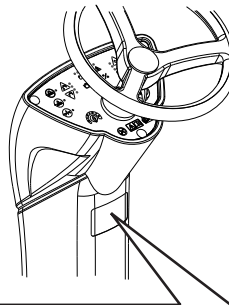
The machine model and serial number are marked on the plate (see the example to the side). Product code and year of production are marked on the same plate. This information is useful when requiring machine spare parts. Use the following table to write down the machine identification data.



Model: Scrubber-Dryer FOCUS II M. Rider 26D		Serial No:
Prod. Nr: 9087278020		Date code:
GVW: 459 kg/1012 lb	IPX4	LpA = 65 dB(A)
63 A	Charg.100-240Vac 50-60 Hz	Battery 24 Vdc
Type E Floor cleaning machine		
 Intertek	Conform to:	Control Nr:
	UL STD 583	3084826
Certified to:	2% 	
CSA STD C22.2 N.68-92		
 A Nilfisk-Advance Brand		"Made in Hungary" 14600 21st Ave N Plymouth, MN, USA www.clarkeus.com

P100674

MACHINE model
PRODUCT code
MACHINE serial number

Safety

The following symbols indicate potentially dangerous situations. Always read this information carefully and take all necessary precautions to safeguard people and property.

Symbols



Danger! *It indicates a dangerous situation with risk of death for the operator.*



Warning! *It indicates a potential risk of injury for people or damage to objects.*



Caution! *It indicates a caution related to important or useful functions.*



Note: *It indicates a remark related to important or useful functions.*

General Instructions

Specific warnings and cautions to inform about potential damages to people and machine are shown below.



Warning! *Make sure to follow the safety precautions to avoid situations that may lead to serious injuries.*

- Before performing any maintenance, repair, cleaning or replacement procedure disconnect the battery connector and remove the ignition key.
- This machine must be used by properly trained operators only.
- Keep the batteries away from sparks, flames and incandescent material. During the normal operation explosive gases are released.
- Do not wear jewelry when working near electrical components.
- Do not work under the lifted machine without supporting it with safety stands.
- Do not operate the machine near toxic, dangerous, flammable and/or explosive powders, liquids or vapors: This machine is not suitable for collecting dangerous powders.
- Battery charging produces highly explosive hydrogen gas. Keep the tank assembly open during battery charging and perform this procedure in well-ventilated areas and away from naked flames.



Caution! *Make sure to follow the safety precautions to avoid situations that may lead to serious injuries, damages to materials or equipments.*

- Carefully read all the instructions before performing any maintenance/repair procedure.
- Before using the battery charger, ensure that frequency and voltage values, indicated on the machine serial number plate, match the electrical mains voltage.
- Do not pull or carry the machine by the battery charger cable and never use the battery charger cable as a handle. Do not close a door on the battery charger cable, or pull the battery charger cable around sharp edges or corners. Do not run the machine on the battery charger cable.
- Keep the battery charger cable away from heated surfaces.
- Do not use the machine if the battery charger cable or plug is damaged. If the machine is not working as it should, has been damaged, left outdoors or dropped into water, return it to the Service Center.
- To reduce the risk of fire, electric shock, or injury, do not leave the machine unattended when it is plugged in. Before performing any maintenance procedure, disconnect the battery charger cable from the electrical mains.
- Do not smoke while charging the batteries.
- To avoid any unauthorized use of the machine, remove the ignition key.
- Do not leave the machine unattended without being sure that it cannot move independently.
- Always protect the machine against the sun, rain and bad weather, both under operation and inactivity condition. Store the machine indoors, in a dry place: This machine must be used in dry conditions, it must not be used or kept outdoors in wet conditions.
- Before using the machine, close all doors and/or covers as shown in the User Manual.
- This machine is not intended for use by persons (including children) with reduced physical, sensory or mental capabilities, or lack of experience and knowledge, unless they have been given supervision or instruction concerning use of the machine by a person responsible for their safety. Children should be supervised to ensure that they do not play with the machine.
- Close attention is necessary when the machine is used near children.
- Use only as shown in this Manual. Use only Nilfisk's recommended accessories.
- Take all necessary precautions to prevent hair, jewelry and loose clothes from being caught by the machine moving parts.
- Do not use the machine on slopes with a gradient exceeding the specifications.
- Do not use the machine in particularly dusty areas.
- Use the machine only where a proper lighting is provided.
- If the machine is to be used where there are other people besides the operator, it is necessary to install the pivoting light and the reverse gear buzzer (optional).
- While using this machine, take care not to cause damage to people or objects.
- Do not bump into shelves or scaffoldings, especially where there is a risk of falling objects.
- Do not put any can containing fluids on the machine.

- The machine working temperature must be between 0 °C and +40 °C.
- The machine storage temperature must be between 0 °C and +40 °C.
- The humidity must be between 30% and 95%.
- When using floor cleaning detergents, follow the instructions on the labels of the detergent bottles.
- To handle floor cleaning detergents, wear suitable gloves and protections.
- Do not use the machine as a means of transport.
- Do not allow the brushes to operate while the machine is stationary to avoid damaging the floor.
- In case of fire, use a powder fire extinguisher, not a water one.
- Do not tamper with the machine safety guards and follow the ordinary maintenance instructions scrupulously.
- Do not allow any object to enter into the openings. Do not use the machine if the openings are clogged. Always keep the openings free from dust, hairs and any other foreign material which could reduce the air flow.
- Do not remove or modify the plates affixed to the machine.
- To manually move the machine, the electromagnetic brake must be disengaged. After moving the machine manually, engage the electromagnetic brake again. Do not use the machine when the electromagnetic brake handwheel is screwed down.
- When the machine is to be pushed for service reasons (missing or discharged batteries, etc.), the speed must not exceed 4 km/h.
- This machine cannot be used on roads or public streets.
- Pay attention during machine transportation when temperature is below freezing point. The water in the recovery tank or in the hoses could freeze and seriously damage the machine.
- Use brushes and pads supplied with the machine and those specified in the User Manual. Using other brushes or pads could reduce safety.
- In case of machine malfunctions, ensure that these are not due to lack of maintenance. Otherwise, request assistance from the authorised personnel or from an authorised Service Center.
- If parts must be replaced, require ORIGINAL spare parts from an Authorised Dealer or Retailer.
- To ensure machine proper and safe operation, the scheduled maintenance shown in the relevant chapter of this Manual, must be performed by the authorised personnel or by an authorised Service Center.
- Do not wash the machine with direct or pressurised water jets, or with corrosive substances.
- When WET batteries are installed on the machine, do not tilt the machine for more than 30° from the horizontal plane to prevent the highly corrosive acid from leaking out of the batteries. If the machine must be tilted to perform any maintenance procedure, remove the batteries.
- The machine must be disposed of properly, because of the presence of toxic-harmful materials (batteries, etc.), which are subject to standards that require disposal in special centres (see Scrapping chapter).

Machine Lifting



Warning! Do not work under the lifted machine without supporting it with safety stands.

Machine Transportation



Warning! Before transporting the machine, make sure that:

All covers are closed.

The ignition key is removed.

The battery connector disconnected.

The machine is securely fastened to the means of transport.

Machine Nomenclature (know your machine)

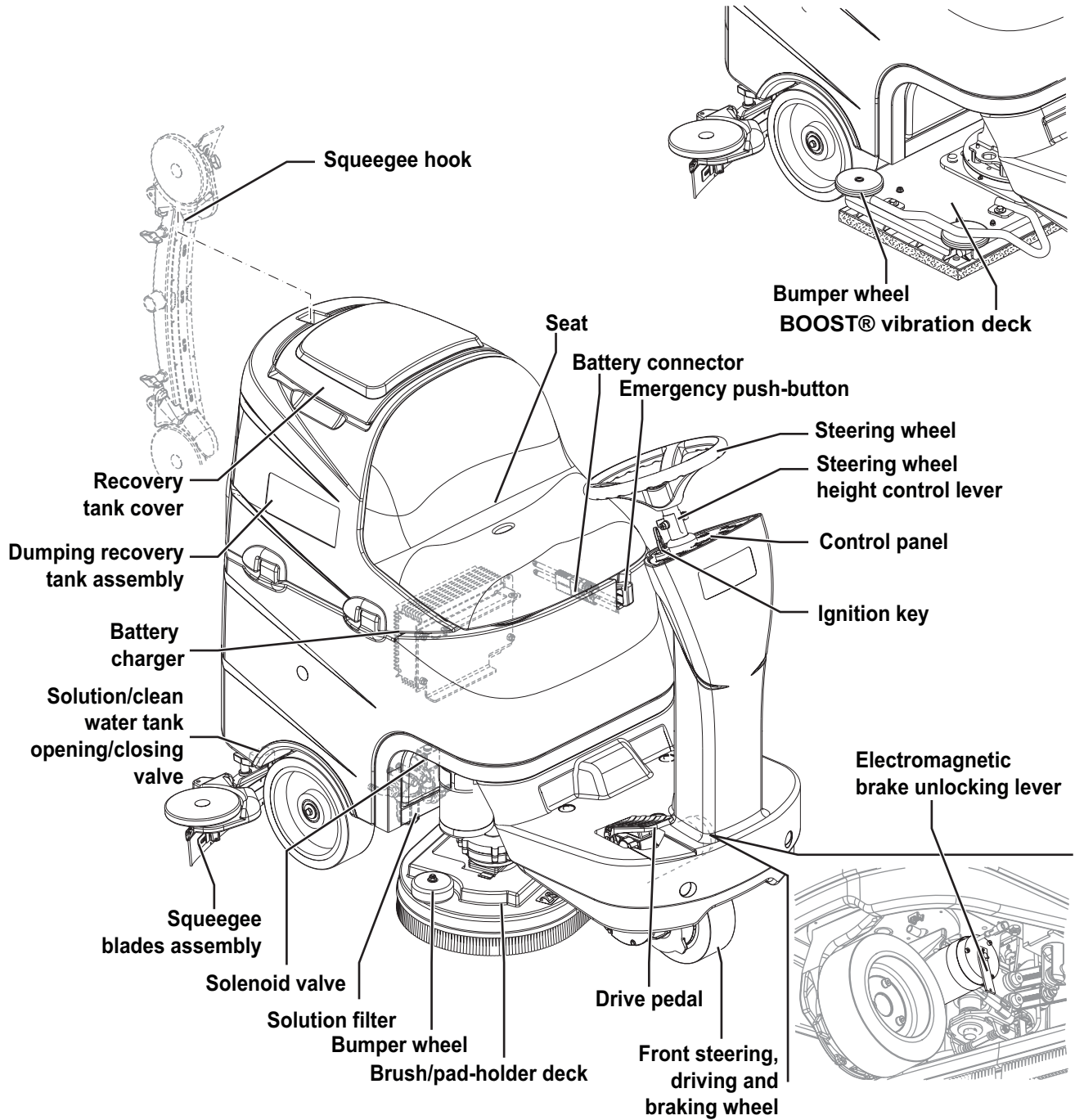

Machine Nomenclature (continued)

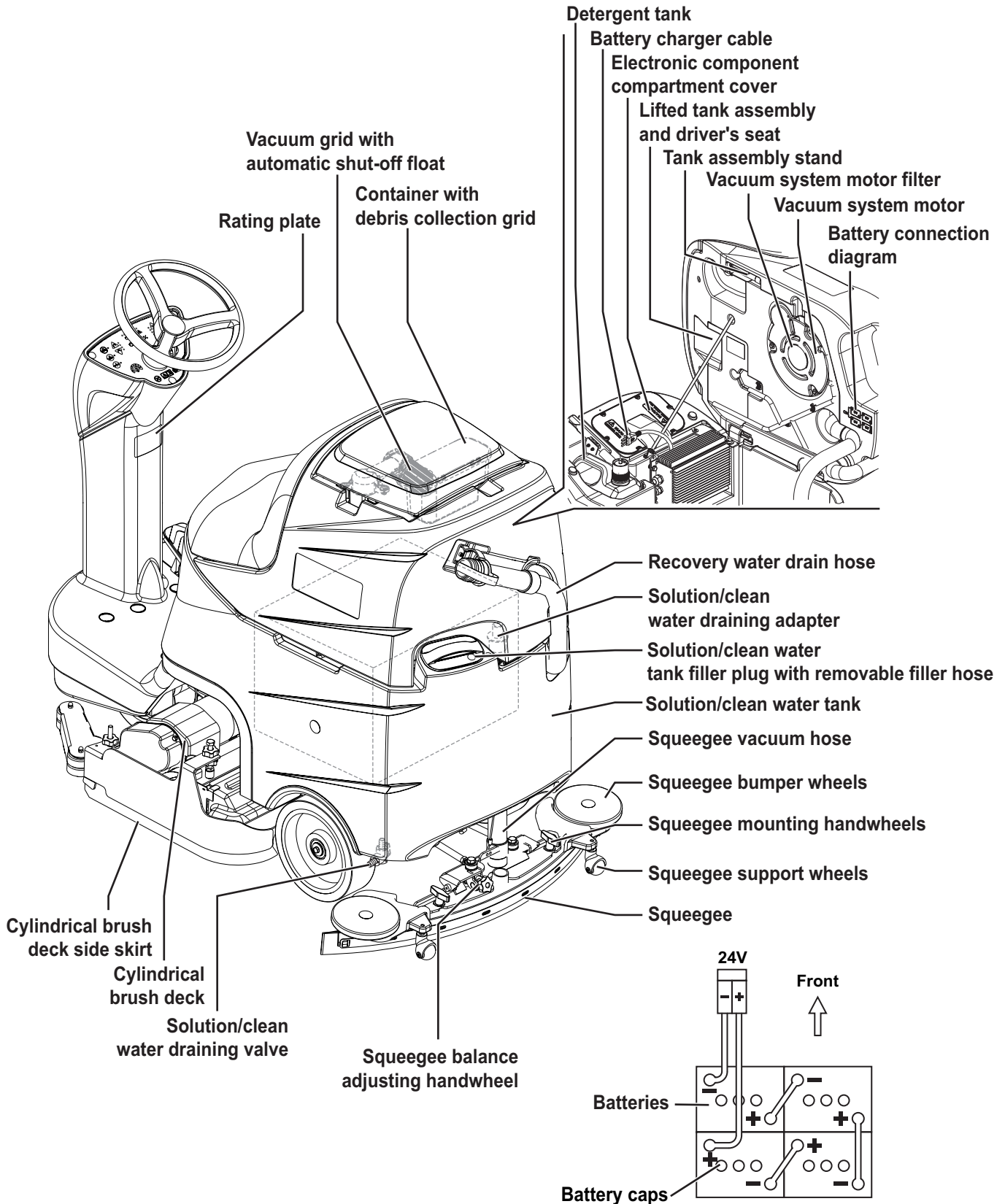

Control Panel

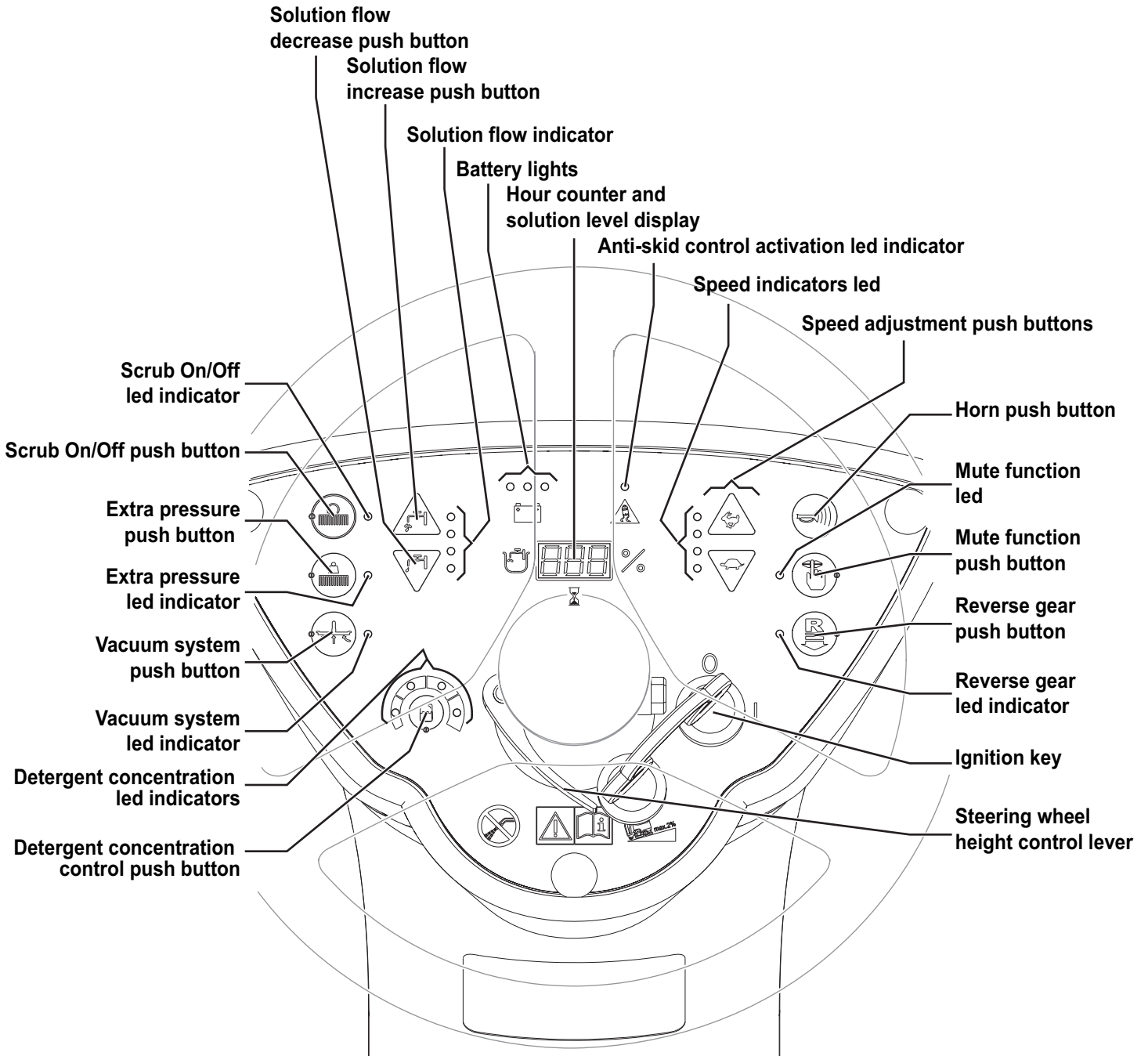

Service and Diagnostic Equipment

Besides a complete set of standard meters, the following instruments are necessary to perform fast checks and repairs on Nilfisk-Advance machines:

- Laptop computer charged with the current version of EzParts, Adobe Reader and (if possible) Internet connection
- Digital Volt Meter (DVM)
- Amperometric pliers with possibility of making DC measurements
- Hydrometer
- Battery charge tester to check 12V batteries
- Static control wrist strap
- Dynamometric wrench set
- A copy of the User Manual and Spare Parts List of the machine to be serviced (provided with the machine or available at www.advance-us.com or other Nilfisk-Advance websites).

The following equipment is also available at Nilfisk-Advance Centers:

- Vacuum water lift gauge, P/N 56205281

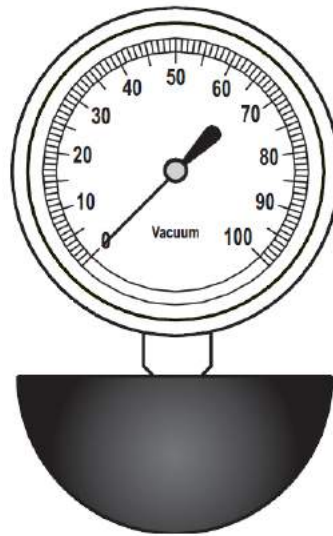

- Italsea universal programmer, P/N 9097297000



Technical Data

General technical data				
Description	SCRUBTEC R 466 - FOCUS II Micro Rider 26D	SCRUBTEC R 471	SCRUBTEC R 471C	SCRUBTEC BOOST® R4 - FOCUS II Micro Rider 28 BOOST
Cleaning width	26 in (660 mm)	28 in (710 mm)	28 in (710 mm)	28 in (710 mm)
Squeegee width	35 in (890 mm)			
Solution/clean water tank capacity	21.1 US gal (80 L)			
Solution/clean water tank capacity	21.1 US gal (80 L)			
Min/max solution flow (with and without Chemical Mixing System)	0 ÷ 0.8 gpm (0 ÷ 3.0 L/min)			
Chemical Mixing System kit detergent concentration settings	0,4% - 0,75% - 1,5% - 2,5%			
Rear wheel diameter	9.8 in (250 mm)			
Rear wheel specific pressure on the floor (*)	130 psi (0.9 N/mm ²)			
Front steering, driving and braking wheel diameter	8.8 in (225 mm)			
Front wheel specific pressure on the floor (*)	72 psi (0.5 N/mm ²)			
Vacuum system motor power	0.56 hp (420 W) (0.9 hp (670 W) optional)			
Drive system motor power	0.4 hp (300 W)			
Maximum speed	3.7 mph (6 km/h)			
Maximum gradient when working	2%			
Sound pressure level at workstation (ISO 11201, ISO 4871, EN 60335-2-72) (LpA)	65 dB(A) ± 3 dB(A)			
Machine sound pressure level (ISO 3744, ISO 4871, EN 60335-2-72) (LwA)	82 dB(A)			83 dB(A)
Vibration level at the operator's arms (ISO 5349-1, EN 60335-2-72)	< 98.4 in/s ² (< 2.5 m/s ²)			
Vibration level at the operator's body (ISO 2631-1, EN 60335-2-72)	< 31.4 in/s ² (< 0.8 m/s ²)			
Battery compartment size (length x width x height)	14.9 x 21.5 x 11.8 in (380 x 540 x 300 mm)			
Battery type	4 6V batteries, 180 Ah C5 (WET)			
	4 6V batteries, 180 Ah C5 (GEL/AGM)			
Standard batteries autonomy	2,5 - 3,5 hours			
Total electrical input	60 A			
Machine height	48.4 in (1,230 mm)			
Machine maximum length	53.5 in (1,360 mm)			
Minimum turning radius	59.0 in (1,500 mm)			
Machine width without squeegee	26.4 in (670 mm)	29,4 in (748 mm)	31,9 in (810 mm)	28.7 in (730 mm)
Vacuum performance	0.0098 MPa (1,000 mm/H ₂ O)			

(*) Machines have been tested under the following conditions:

- With operator on board (165.3 lb - 75 kg)
- Maximum battery size
- Maximum brush and squeegee size
- Full clean water tank
- Optional components installed
- Weight on wheels checked
- Print on the floor checked on cement for each single wheel
- Result expressed as maximum value for front and rear wheels

Technical Data (continued)

Technical data for machines with brush/pad-holder deck		
Description	SCRUBTEC R 466 - FOCUS II Micro Rider 26D	SCRUBTEC R 471
Brush/pad diameter	13 in (330 mm)	14 in (355 mm)
Weight without batteries and with empty tanks	385.8 lb (175 kg)	390,2 lb (177 kg)
Maximum weight with batteries, full tanks and operator (GVW)	983.2 in (446 kg)	987,6 lb (448 kg)
Hourly efficiency [2,5 mph (4 km/h)]	~ 24,488 ft ² (~ 2,275 m ²)	~ 26.909 ft ² (~ 2.500 m ²)
Deck right/left offset (variable)	0 ÷ 3.9 in / 1.0 ÷ 0 in (80 ÷ 100 mm / 25 ÷ 0 mm)	0,6 ÷ 5,9 in / 4,1÷/ 0 in (15 ÷ 150 mm / 105 ÷ 0 mm)
Brush distance from the floor (when lifted)	1.9 in (48 mm)	
Brush/pad-holder motor power	2 x 0.53 hp (2 x 400 W)	
Brush/pad-holder speed	230 giri/min	
Brush/pad-holder pressure with extra-pressure function turned off	66 lb (30 kg)	70,5 lb (32 kg)
Brush/pad-holder pressure with extra-pressure function turned on	105.8 lb (48 kg)	110,2 lb (50 kg)

Technical data for machines with cylindrical deck	
Description	SCRUBTEC R 471C
Cylindrical brush size (diameter x length)	5,7 x 27 in (145 x 690 mm)
Weight without batteries and with empty tanks	396,8 lb (180 kg)
Maximum weight with batteries, full tanks and operator (GVW)	994,2 lb (451 kg)
Hourly efficiency [2,5 mph (4 km/h)]	~ 26.909 ft ² (~ 2.500 m ²)
Deck right/left offset	3,5 / 3,5 in (90 / 90 mm)
Cylindrical brush deck distance from the floor (when lifted)	0,87 in (22 mm)
Cylindrical brush motor power	2 x 0,8 hp (2 x 600 W)
Cylindrical brush speed	720 giri/min
Cylindrical brush pressure	77,1 lb (35 kg)

Technical Data with BOOST® deck	
Description	SCRUBTEC BOOST® R4 - FOCUS II Micro Rider 28 BOOST
Pad size	28 x 14 in (711 x 355.6 mm)
Weight without batteries and with empty tanks	401 lb (182 kg)
Maximum weight with batteries, full tanks and operator (GVW)	1,005 lb (456 kg)
Hourly efficiency [2,5 mph (4 km/h)]	~ 26,909 ft ² (~ 2,500 m ²)
Deck right/left offset (variable)	0 ÷ 8.6 in / 4.9 ÷ 0 in (0 ÷ 220 mm / 125 ÷ 0 mm)
BOOST® deck distance from the floor (when lifted)	1.9 in (48 mm)
BOOST® deck motor power	0.75 hp (560 W)
Motor speed	2,200 giri/min
BOOST® deck pressure with extra-pressure function turned off	66 lb (30 kg)
BOOST® deck pressure with extra-pressure function turned on	105.8 lb (48 kg)

Dimensions

SCRUBTEC R 466 - FOCUS II Micro Rider 26D

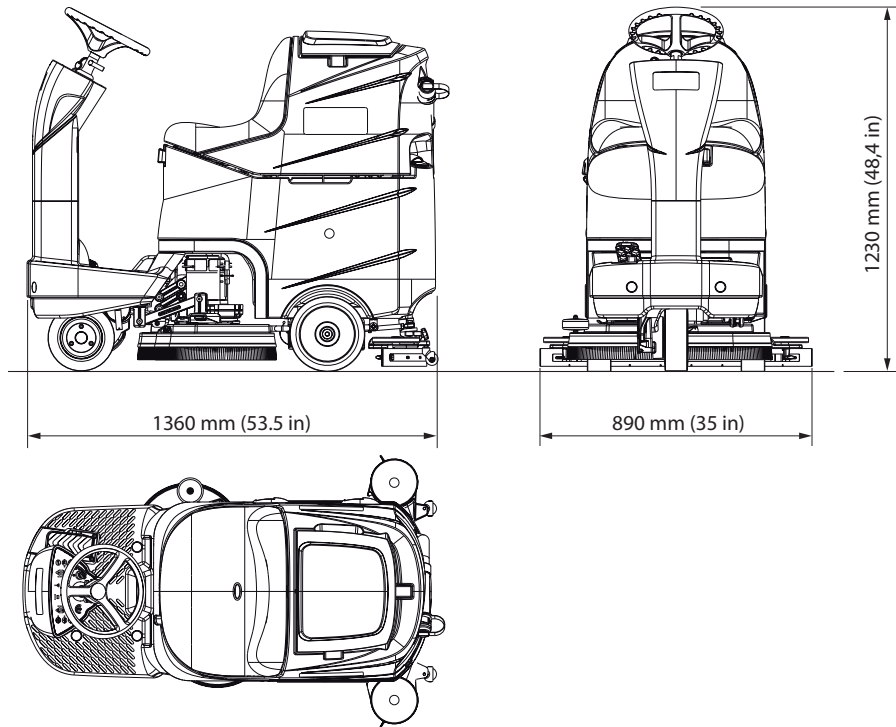

P100678

SCRUBTEC R 471

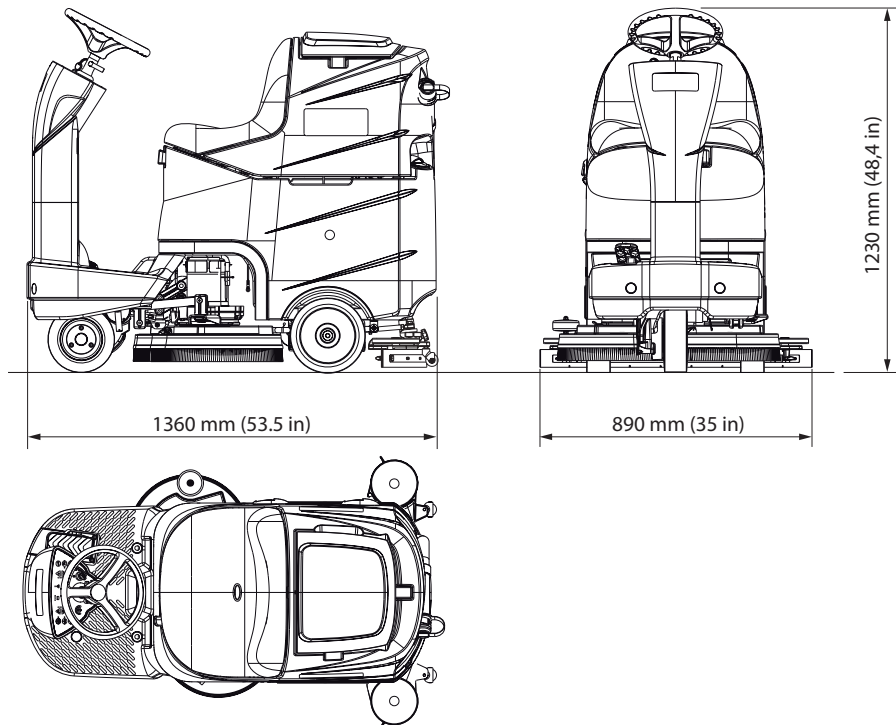

P100679

Dimensions (continued)

SCRUBTEC R 471C

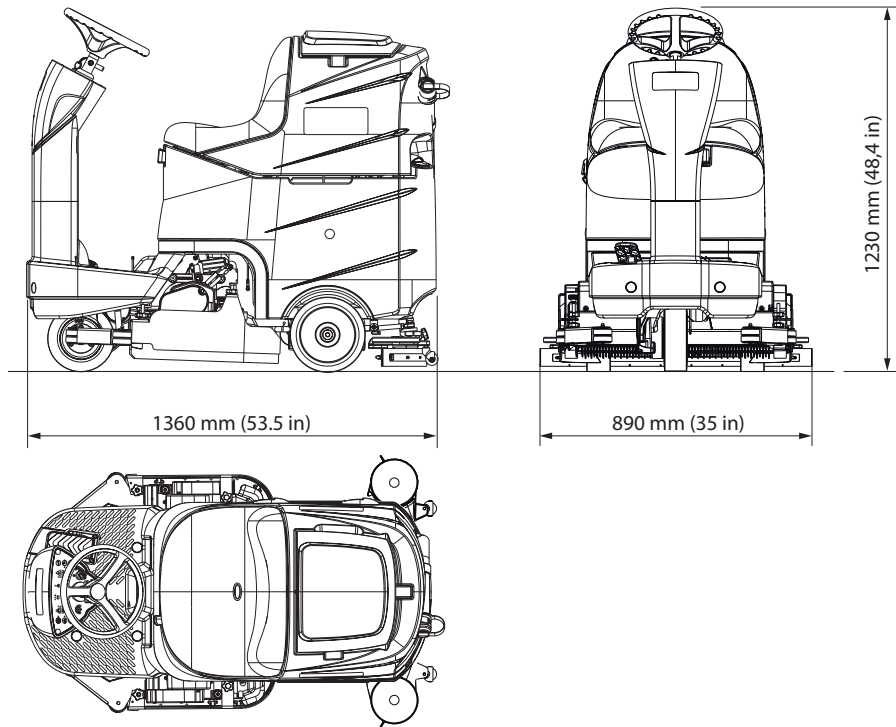

P100680

SCRUBTEC BOOST® R4 - FOCUS II Micro Rider 18 BOOST®

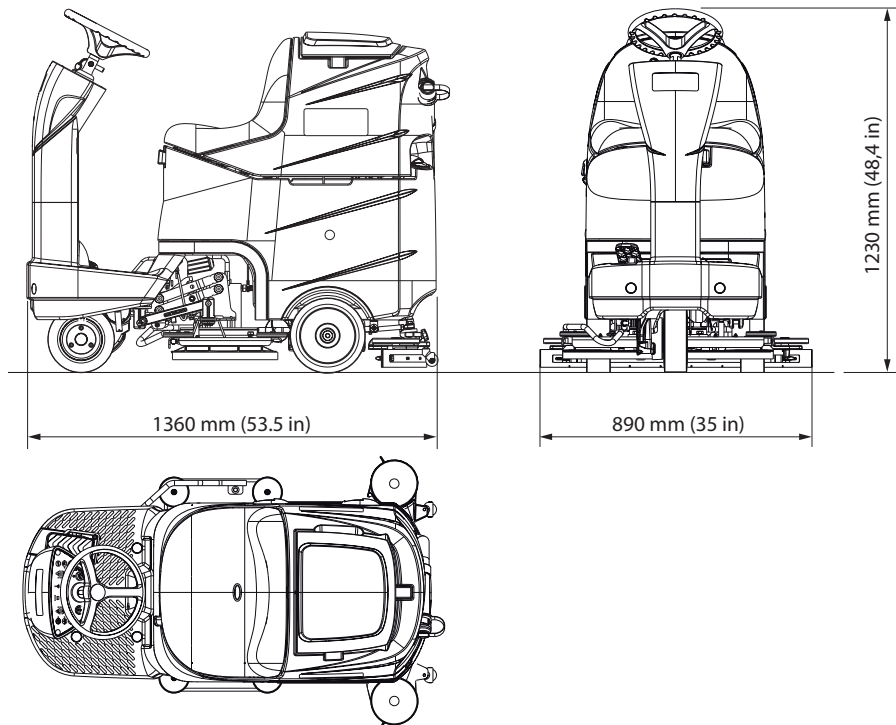

P100681

Maintenance

The lifespan of the machine and its maximum operating safety are ensured by correct and regular maintenance.



Warning! Read carefully the instructions in the Safety chapter before performing any maintenance procedure.

The following tables provides the scheduled maintenance. The intervals shown may vary according to particular working conditions, which are to be defined by the person in charge of the maintenance.

For instructions on maintenance procedures, see the following paragraphs.

Scheduled Maintenance Table

Procedure	Daily, after using the machine	Weekly	Every six months	Yearly
Battery charging				
Squeegee cleaning				
Brush/cylindrical brush cleaning				
Tank, debris collection grid and vacuum grid with float cleaning, and cover gasket check				
Chemical Mixing System system cleaning and draining (optional)				
Squeegee blade check and replacement				
Side skirt check (only for R 471C)				
Solution filter cleaning				
Vacuum system motor filter cleaning				
Battery (WET) fluid level check				
Screw and nut tightening check			(1)	
Check and adjustment of driving belts between motors and cylindrical brushes (only for R 471C)				
Electromagnetic brake efficiency check				
Brush/pad-holder motor carbon brush check or replacement				
Vacuum system motor carbon brush check or replacement				
Drive system motor carbon brush check or replacement				

(1) And after the first 8 working hours.

Chassis System

Frame (main parts)

1. Steering assembly plate holder
2. Tanks and driver's seat holder
3. Rear wheels on fixed axle

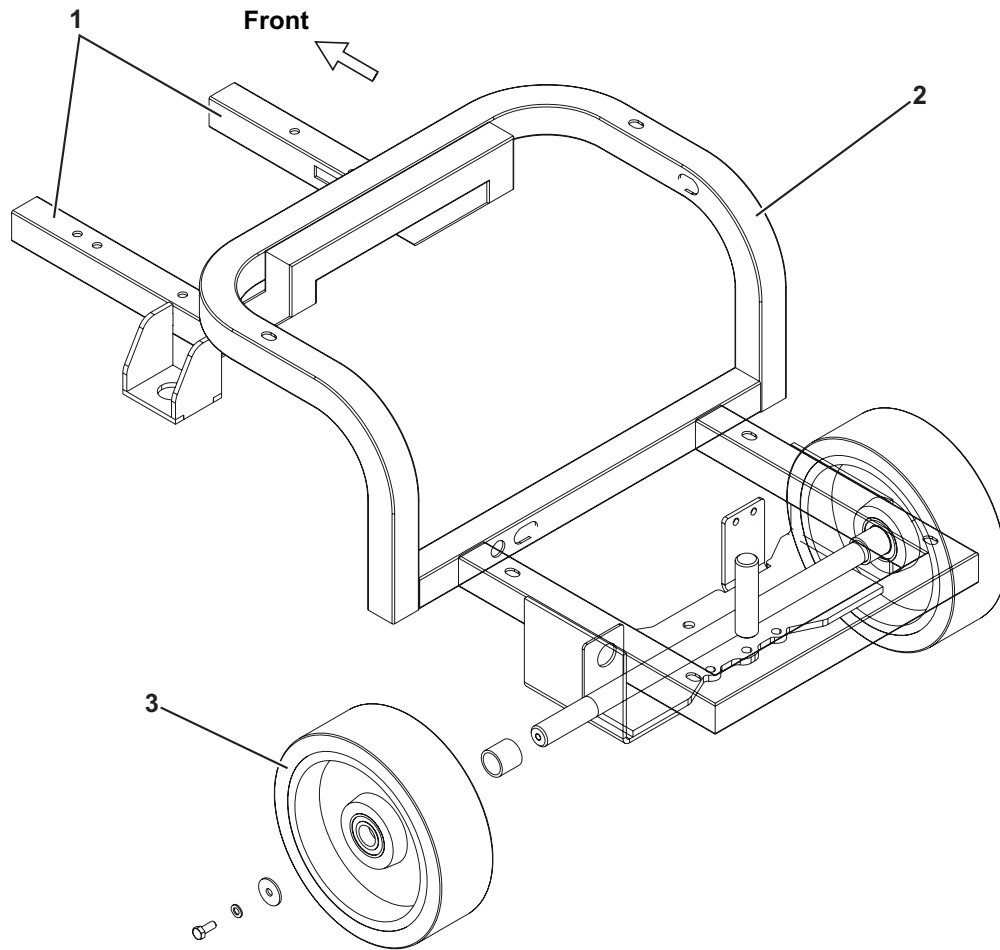

P100682

Control System

Functional Description

The architecture of the electronic system controlling the electrical machine utilities consists of a function electronic board (EB1), and a display electronic board (EB2) which is connected to the dashboard (EB3) - the main user interface.

The function electronic board (EB1) manages all the utilities.

It drives directly the following accessories:

- Drive system motor with electromagnetic parking brake
- Vacuum system motor
- Deck actuator
- Squeegee actuator
- Solution flow solenoid valve
- Detergent pump
- Buzzer

It drives the brush deck motors by means of the electromagnetic switch.

The display electronic board (EB2) manages all the input signals (push-buttons) and the output signals (LED) from dashboard (EB3) to which it is connected by 2 flat cables.

There is also a 3-figure display on the display electronic board (EB2), which is mainly used to display the hour counter, the solution tank level, and for any alarms (see below). There are also 2 microswitches activated by the levers under the steering wheel.

The display electronic board (EB2) sends all the input and output signals of these components to the function electronic board (EB1) using 2-wire 2-way serial communications protocol.

The system also has an on-board battery charger which also communicates with the function electronic board (EB1) using propriety serial protocol, so the operator can see the operating state (charging phase) on the same user interface of the dashboard (EB3).

Wiring Diagram

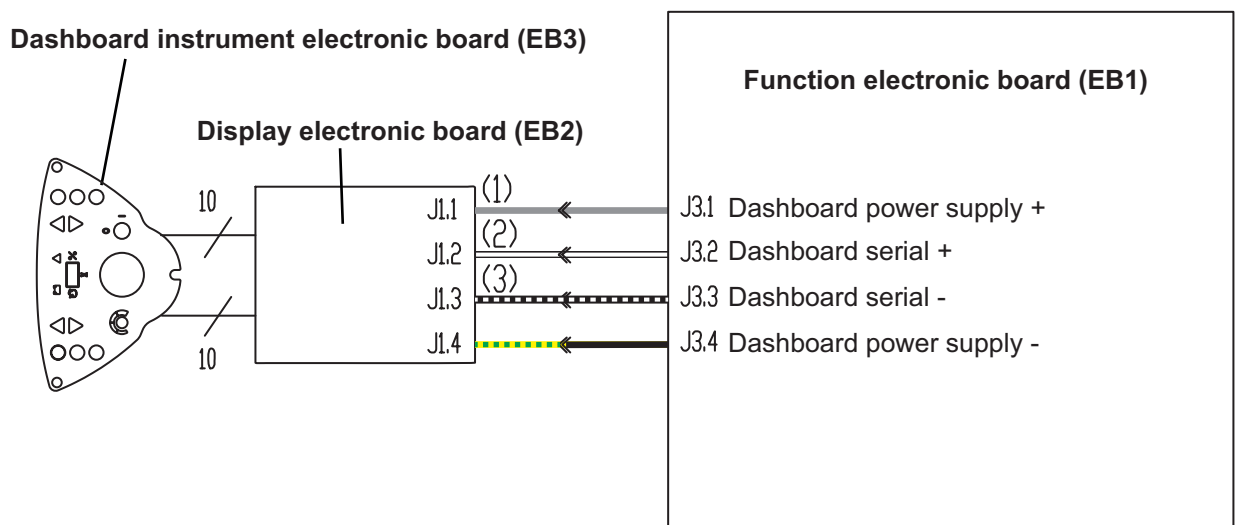

Component Location

- Function electronic board (EB1)
- Display electronic board (EB2)
- Dashboard (EB3)

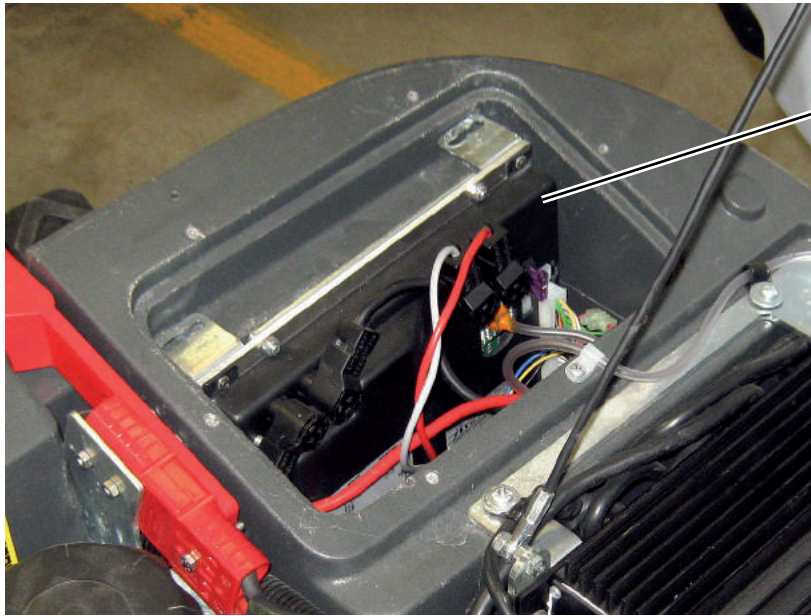

Function electronic board (EB1)

P100684



Display electronic board (EB2)

Dashboard (EB3)

P100685

Function Electronic Board Alarm Codes

The function electronic board indicates a series of alarms in case of malfunction of one or more systems, and in case of abnormal conditions detected in the input signals.

The alarms are shown on the display (71) (except “F6”) by 2 signs following each other: “AL” and “G2”, where G2 is one of the alarm codes (see the descriptions in the following tables).

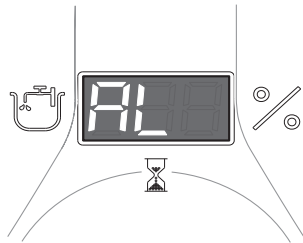

P100686

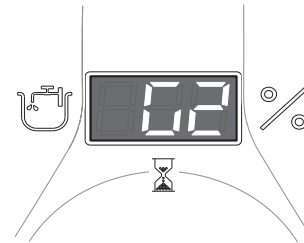

P100687

Also, the alarms are repeated (in case of display malfunction) by the diagnostic LEDs (yellow and red) on the electronic board, as described in the following tables.

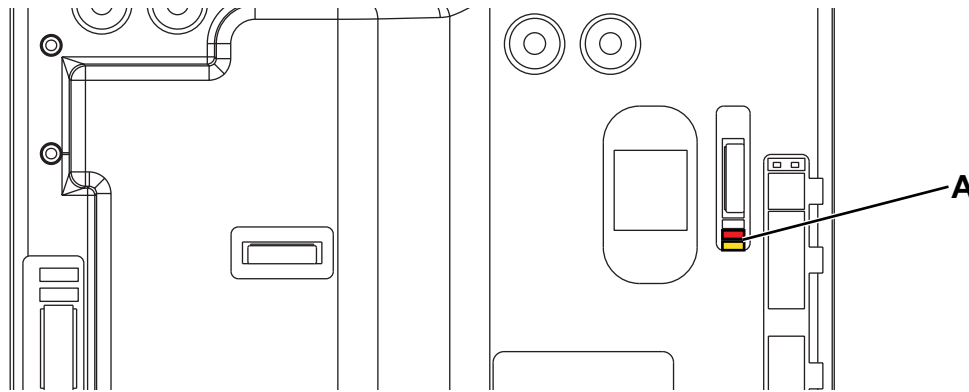

P100688

General alarms

Alarm on the function electronic board - YELLOW LED + RED LED FLASHING

Alarm Code on the display	No. of flashes on the board	Meaning	Condition	Effect	Troubleshooting action
G2	2	EEPROM error.	EEPROM error.	Function block + Default setting reset.	If the machine is normally working after the G2 message appearing, it could be caused by an electromagnetic spike from the environment that didn't damage the system. 1. Check all the parameter (see page 32 - 33) settings (battery type, parameters etc.) because of they could be restored to default.
G3	3	General thermal protection.	The heatsink of the board reached a temperature up to 194 °F (90 °C).	Function block.	1. Check the current flow in the drive motor (it has to be 6-8amps without load and it has to remain below 20 amps during operations). 2. Check the current flow in the vacuum motor (it has to be less than 20 amps). 3. Verify the correct thermal dissipation of the board: the correct installation on the metal bracket, obstacles to the air flow from the bottom (deck area) to the extraction hole on the top cover of the electric box. 4. If all is ok, it could be generated by extreme working conditions like room temperature >30°C, slopes in the working path. The machine has to be maintained off in order to restore the right temperature into the board and then it could be used.

General alarms

Alarm on the function electronic board - YELLOW LED + RED LED FLASHING

<i>Alarm Code on the display</i>	<i>No. of flashes on the board</i>	<i>Meaning</i>	<i>Condition</i>	<i>Effect</i>	<i>Troubleshooting action</i>
G4	4	Blown F2 fuse.	Blown F2 fuse.	Function block.	F2 fuse is a power safety fuse (100 amps rated) and its primary function is to avoid that a short drive so much current to generate smoke or fire into the board. The F2 opening is normally due to a severe damage of the board. <ol style="list-style-type: none"> 1. Open the board plastic cover to verify the condition of the board. 2. If everything seems ok try to substitute F2 fuse otherwise substitute the board. 3. Take care to properly tight the fuse .
G5	5	Wrong KEY sequence.	Voltage dip (of the order of 100ms or less) of the key input.	Function block.	<ol style="list-style-type: none"> 1. Check any bad contact in the key switch. 2. Check for any bad contact in the wires from the key switch to the pin 5 and 6 of J3 connector on the board. 3. If necessary substitute the key switch.
G6	6	No signal from BATTERY CHARGER	No signal from battery charger on the communication yellow wire to pin 11 of J1 connector	The charging battery phase is not shown	<ol style="list-style-type: none"> 1. Check the continuity of the yellow wire from the 3 way charger connector to pin 11 of J1 connector. 2. If ok, it is necessary to substitute the charger or the board.
G7	7	Undervoltage.	The battery voltage stay for more than 10 seconds lower than 18,4 Volt (for WET batteries, 19,6 Volt for GEL-AGM batteries).	Function block.	<ol style="list-style-type: none"> 1. Check the battery voltage without and with load. If necessary substitute the bad batteries. 2. Charge the batteries with a complete charging cycle.
G8	8	Serial communication error with dashboard electronic board.	No signal or decoding error in the communication between the function electronic board (EB1) and the display electronic board (EB2).	No block.	<ol style="list-style-type: none"> 1. Check the 4 wires from the 4 ways connector on the dashboard to the pin 1,2,3,4 of J3. 2. If ok substitute the dashboard.
G9	9	Battery voltage drop.	Battery voltage drop bigger than 3 Volt in less than 1 second.	Drive system + electromagnetic brake block.	G9 typically shows that the red safety button under the seat (that mechanically open the ANDERSON CONNECTOR) was pressed during the machine operation. If this is not the case, check the power wirings from the batteries to the ANDERSON connector: it could be a bad contact in one of these power connections. Otherwise it could be caused by one or more batteries damaged or to be replaced.

Function Electronic Board Alarm Codes (continued)

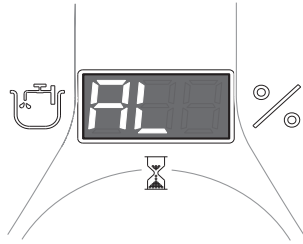

P100686

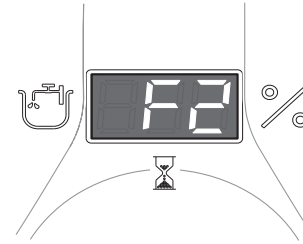

P100689

Function electronic board alarms

Alarm on the function electronic board - RED LED FLASHING

Alarm Code on the display	No. of flashes on the board	Meaning	Condition	Effect	Troubleshooting action
F2	2	BRUSH motor amperometric protection.	The voltage drop measured on the F1 fuse is higher than the value of the parameter (see page 32 - 33) VS1 (for disc deck, VS2 for cylindrical deck).	Brush electromagnetic switch output block.	<ol style="list-style-type: none"> 1. Check the current flow in the brush motors (the sum of the 2 motors has to be under 50 amps on disc decks, under 70 amps on cylindrical decks). 2. If the current is ok check the correct tight of the F1 fuse nuts (F1 fuse is on the bracket under the function board).
F3	3	VACUUM SYSTEM amperometric protection	The current draw in the vacuum motor is higher than 30 Amp for more than 10 seconds.	Vacuum system block	<ol style="list-style-type: none"> 1. Check for any debris into the vacuum motor 2. Check that the vacuum motor fan is free to rotate (bearing stuck ?). 3. If necessary substitute the vacuum motor.
F4	4	DECK ACTUATOR position irregularity.	End-of-stroke microswitch configuration not plausible or end-of-stroke microswitch not reached within 10 seconds.	Deck actuator block.	<ol style="list-style-type: none"> 1. Check the deck actuator wire and its connection to the 6 way J4 connector on the board. 2. Check for any obstacle or excessive friction that don't allow the actuator to move. 3. If necessary substitute the actuator.
F5	5	VACUUM SYSTEM power section damage.	Internal board mosfet short circuit.	Vacuum system block.	<ol style="list-style-type: none"> 1. Check any short in the vacuum motor wiring. 2. Check the vacuum motor operation (try to power it directly). 3. Substitute the board.
F6	6	PRESSURE SWITCH signal fault.	Pressure switch input higher than 4.0 Volt.	Water level visualization missing + water flow and % detergent management fault.	<ol style="list-style-type: none"> 1. Check for the correct positioning of the pressure gauge module into the board: take care of the 2 side connectors that have to be fitted in properly. 2. If the connection is ok, substitute ALL THE pressure gauge KIT.
F7	7	VACUUM SYSTEM output short circuit.	The inrush current draw in the vacuum motor is higher than 100 amps.	Vacuum system block.	<ol style="list-style-type: none"> 1. Check any short in the vacuum motor wiring. 2. Check the vacuum motor operation (try to power it directly). 3. Substitute the vacuum motor.
F8	8	Function general relay fault.	The main relays inside the board is stuck (always closed or always open).	Function block.	Substitute the board.

All “general” and “function” alarms, and their relevant effects remain until reset from KEY input. In case of simultaneous errors, the one with greater priority is shown first (priority order is opposite to the number of flashes).

Function Electronic Board Alarm Codes (continued)

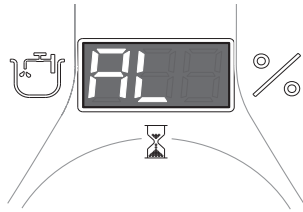

P100686

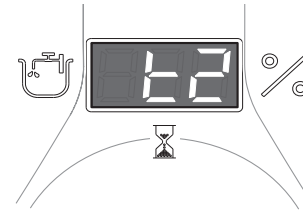

P100690

Drive system alarms

Alarm on the function electronic board - YELLOW LED FLASHING

Alarm Code on the display	No. of flashes on the board	Meaning	Condition	Troubleshooting action
t2	2	Amperometric protection intervention.	Current draw in to the drive motor higher than the parameter (see page 32 - 33) "INOM" for more than parameter (see page 32 - 33) "TMAX" time.	Check the drive motor current draw: it has to be 6-8 amps without load and it has to remain under 20 amps during operation.
t3	3	Electromagnetic brake not present	Open circuit between J5.1 and J5.2	<ol style="list-style-type: none"> 1. Check the continuity of the 2 wires of the electrobrake of the motorwheel up to the 2 way connector J5 on the board. 2. Check for the electrobrake impedance: has to be about 40 Ohms. 3. If necessary substitute the electrobrake.
t4	4	Pedal input activated by ignition.	Pedal output on J3.8 higher than the parameter (see page 32 - 33) "DEADL" when the machine was switched on by the key.	<ol style="list-style-type: none"> 1. Check that the pedal returns into its released position when not pressed. 2. If necessary substitute the pedal.
t5	5	Drive system power section damage.	Internal board mosfet short circuit.	<ol style="list-style-type: none"> 1. Check any short in the main motorwheel wires. 2. Try to disconnect the 2 Ø6 mm fast connectors M1 and M2 from the board, switch on the machine and press the pedal. 3. If the alarm still appears, substitute the board.
t6	6	Pedal input not admitted.	Open circuit between J3.7 and J3.9 or pedal output on J3.8 higher than 5 Volt.	Check the wiring from the pedal and the J3 connector pins 7, 8, 9. From the battery – you have to measure: <ul style="list-style-type: none"> - About 5 Volt on pin 7. - From 0.7 to 4.5 Volt on pin 8 (it has to change moving the pedal). - About 0 – 0.7 Volt on pin 9.
t7	7	Overcurrent (motor D.C.).	Drive motor current higher than 1.5 times the value of the parameter (see page 32 - 33) "IMAX".	<ol style="list-style-type: none"> 1. Check any short in the main motorwheel wires. 2. Check the impedance of the motorwheel motor: it has to be about 0.6 – 0.8 Ohms. 3. If necessary substitute the motorwheel motor.
t8	8	Drive system relay fault.	The Drive system relays inside the board is stuck (always closed or always open).	Substitute the board.

All the drive system alarms activates to cut off the power supply to the driving wheel motor (not to the ELECTROMAGNETIC BRAKE), until reset from KEY input [except alarm t4 which is reset as soon as J3.8 voltage (drive pedal output) became less then the value of the parameter "DEADL" (see table "Function electronic board parameters" page 32 - 33). In case of simultaneous errors, the one with greater priority is shown first (priority order is opposite to the number of flashes).

Function Electronic Board Alarm Codes (continued)

Other alarm indications on the display		
Alarm Code on the display	Meaning	Condition
“---”	Water level signal missing or not as specified.	Pressure switch module output higher than 4.0 Volt.
“888”	Serial communication problem between dashboard electronic board and function electronic board.	Signal missing or errors.
Off	Dashboard electronic board power supply missing.	Voltage between J1.1 and J1.4 less than 12 Volt.

Black-box: Record of Alarms, Battery Management Parameters (see page 32 - 33), Partial Hour Counter

The data indicated in the following table (ALARMS, BATTERY MANAGEMENT DATA) are stored in the non-volatile memory of the electronic board and can be recalled and displayed by the external programmer (ITAL-SEA UNIVERSAL PROGRAMMER, NILFISK P/N 9097297000) connect to port J9. For each stored datum (event) the value HOURS.MINUTES of the TOTAL hour counter is associated when the alarm occurred. The last 20 events are stored. When the total number of events is used up, the next events overwrite the older ones. The data are shown on the programmer display, listed by decreasing order (starting from the latest) as: DATUM - HOUR (1 per page). The UP and DOWN buttons are used to select 1 page at a time. All the stored paged can be scrolled. The “info” button shows the DATUM - EVENT DESCRIPTION for the selected line.

DATUM	EVENT DESCRIPTION	Condition
G2	EEPROM error	See alarm code description
G3	General thermal protection	See alarm code description
G4	Blown F2 fuse	See alarm code description
G5	Wrong KEY sequence	See alarm code description
G6	No signal from BATTERY CHARGER	See alarm code description
G7	Battery undervoltage	See alarm code description
G8	Serial communication error with dashboard electronic board	See alarm code description
G9	Battery voltage drop	See alarm code description
F2	Brush motor protection intervention	See alarm code description
F3	VACUUM SYSTEM overcurrent	See alarm code description
F4	DECK ACTUATOR position irregularity	See alarm code description
F5	VACUUM SYSTEM power section damage	See alarm code description
F6	PRESSURE SWITCH signal fault	See alarm code description
F7	VACUUM SYSTEM output short circuit	See alarm code description
F8	Function general relay fault	See alarm code description
t2	Drive system amperometric protection intervention	See alarm code description
t3	Electromagnetic brake not present	See alarm code description
t5	Drive system power section damage	See alarm code description
t6	Pedal input not admitted	See alarm code description
t7	Drive system overcurrent	See alarm code description
t8	Drive system relay fault	See alarm code description
GB-N	Time of continuous use with discharged batteries	“N” is the number of hours from the key switching ON and OFF during the battery level is under 18,4 Volt for WET, 19,6 for AGM. This event is not recorded if the above time is less than 10 minutes.
GC	Charging cycle interrupted before completion	Battery charger disconnection before PHASE IV (= with red or yellow LED on)
GD-N	Charging phase duration	N = Number of hours from battery charger connection to completion of PHASE II (red LED on) if < 4

Black-box: Record of Alarms, Battery Management Parameters (see page 32 - 33), Partial Hour Counter (continued)

Example 1:

Last stored alarm: alarm G8 occurred when the machine working hours were 24h and 19m, next to last stored alarm: alarm F4 occurred when the machine working hours were 22h and 5m.

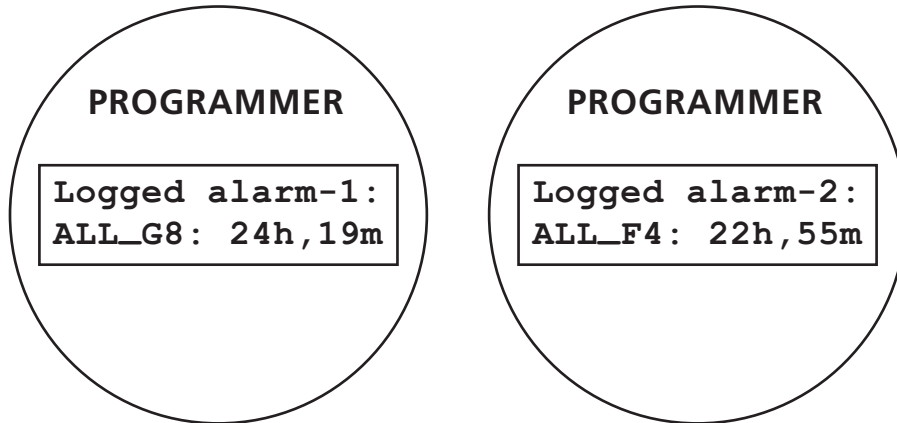

P100691

Example 2:

Charging cycle interrupted before completion when the machine working hours were 15h and 45m (last stored event).

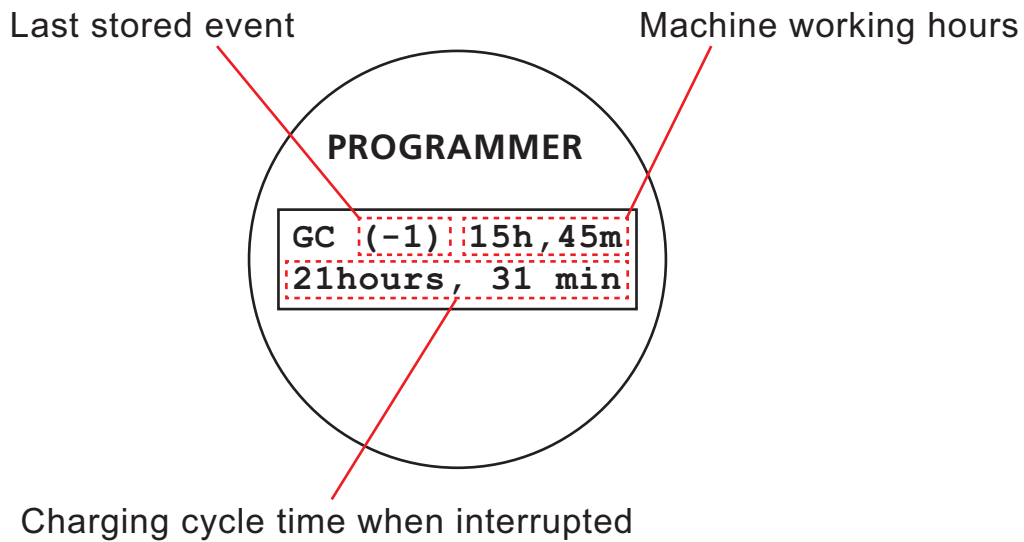

P100692

Display of Current Values of Significant Variables, Hour Counters and Stored Alarms

1. Turn the ignition switch to “0”.
2. Open the electrical component compartment.
3. Connect the **ITALSEA programmer, NILFISK P/N 9097297000** to the function electronic board connector J9 (A).

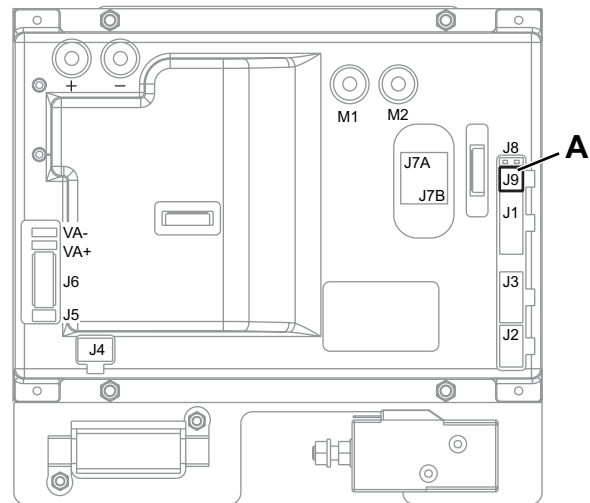
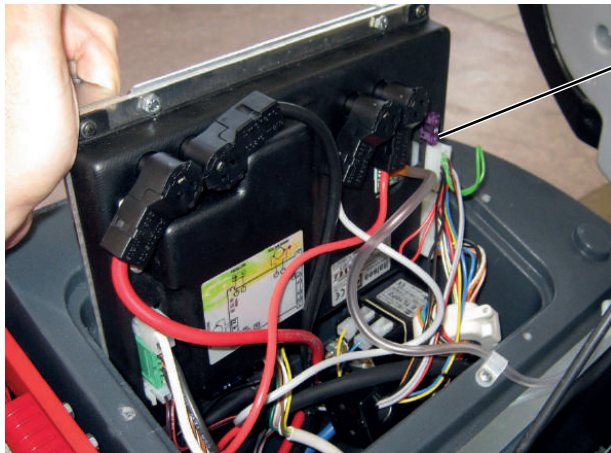

P100693

4. Turn the ignition switch to “T”.
5. Scroll with the UP and DOWN buttons the pages in the order shown in the table below.

Display of Current Values of Significant Variables, Hour Counters and Stored Alarms (continued)

Variable description	Value meaning
Software Release	Software version loaded on the electronic board
Supply Voltage	Battery voltage (V)
Ref. Voltage	Drive pedal input voltage (V)
Drive Motor Voltage	Drive system motor output voltage (V)
Drive Motor Current	Drive system motor current (A)
Brushes Current	Brush deck motor current (mV) (*)
Vacuum Current	Vacuum system motor current (A)
Heatsink Temp.	Temperature detected on the electronic board heatsink (°C)
Hour counter: total	TOTAL HOUR COUNTER (h.min)
Hour counter: drive system	DRIVE SYSTEM HOUR COUNTER (h.min)
Hour counter: brushes	BRUSH HOUR COUNTER (h.min)
Hour counter: vacuum	VACUUM SYSTEM HOUR COUNTER (h.min)
Logged Alarm-N	ALARM STORAGE (possible) (**)

(*) The value is the same as the voltage drop on the F1 fuse, which is proportional to the current but does not have the same value in Amp.

(**) See BLACK-BOX paragraph

Display and Change of Parameters Which can be Set by the Technician

The stored value of each parameter shown in the following table could be modified by the Service Operator from its Default value to another in the range defined from “Min. value” to “Max. value”.

The default value should be ok for most of the applications, however it could be useful to change a parameter value in order to:

- Customize the machine behavior to particular customer needing (like Maximum speed in forward (FVM), max speed in reverse (RVM), maximum and minimum pre-set working speeds (WSMIN and SWMAX if present), reaction time to the pedal pressure variation (AR and DR), time of the CHEMICAL MIXING SYSTEM temporary function (SPT), etc..
- Adapt the board tolerance to particular devices that are a little bit out of their normal tolerances (ex. voltage of the pedal output when released (DEADL), voltage when the pedal is fully pressed (DEADH).
- Adapt the board output power limits to protect the motors in particular heavy duty applications (like Max. current in the deck motors (VS1 for disc, VS2 for cylindrical), max continuous current in the drive motorwheel (INOM) etc.)

1. Turn the ignition switch to “0”.
2. Open the electrical component compartment.
3. Connect the programmer to the function electronic board connector J9 (see figure).
4. Turn the ignition switch to “I”.
5. Press the MODE button.
6. Scroll the parameters with the UP and DOWN buttons to find the one to be changed.
7. Press the MODE button to enter the “change” mode (the parameter starts to flash).
8. Change the value with the UP and DOWN buttons.
9. Store the new set value by pressing the MODE button.

Function Electronic Board Parameters

Parameters which can be set through programming port J9					
Code	Description	Min. values	Default values *	Max. values	Meaning
VRID	Vacuum system partial supply voltage (V)	10	16	20	It is the voltage supplied to the vacuum motor when the SILENCE MODE is active: it could be reduced to reduce further the noise or increased to increase the vacuum performances.
VS1	Brush motor protection threshold 1 (mV)	30	50	90	It is the max current that is possible to supply to the disc brush deck. PAY ATTENTION: increasing this value you will take more overheating risk on the motors.
VS2	Brush motor protection threshold 2 (mV)	30	60	90	It is the max current that is possible to supply to the cylindrical brush deck. PAY ATTENTION: increasing this value you will take more overheating risk on the motors.
DT	Deck actuator m1 microswitch delay (ms)	0	0	10	Engineering parameter to bias the deck actuator normal working position. – Do not modify.
SPT	SPOT function timer (s)	5	60	300	Time of the Chemical Mixing System temporary function (Chemical Mixing System button) after that the normal settings will be restored.
DEADL	Drive pedal bottom dead area (V)	0.0	0.9	1.5	Pedal output voltage when the pedal is in its released position.
DEADH	Drive pedal top dead area (V)	0.0	2.2	2.5	Pedal output voltage when the pedal is fully pressed.
FVM0	Maximum forward speed (%)	10	100	100	Max forward speed.
RVM0	Maximum reverse speed (%)	10	70	100	Max reverse speed.
AR	Maximum acceleration ramp (s)	0.5	3.0	5.0	Time to reach the max forward speed from the stopped position. Increase to have a slower reactive drive behavior, decrease to have a more reactive drive behavior.
DR	Maximum deceleration ramp (s)	0.5	1.0	5.0	Time to reach the machine stopped from the max speed. Increase to have a slower reactive drive behavior, decrease to have a more reactive drive behavior. PAY ATTENTION: increasing this value would make the braking spaces longer.
IR	Maximum deceleration ramp on reversal (s)	0.5	0.5	5.0	Time to reach the machine stopped from the max speed, when the gear is reversed. Increase to have a slower reactive drive behavior, decrease to have a more reactive drive behavior. PAY ATTENTION: increasing this value would make the braking spaces longer.
BRK	Electromagnetic brake activation delay (s)	0.5	1.0	5.0	Delay to the parking brake activation after the machine is stopped. Decrease to allow the machine parking in a slope NOTE: that this machine is not designed to operate on slopes, so in any case advise the customer about that.
INOM	Drive system rated current (A)	10	20	30	It is the max continuous current that is possible to supply to the drive motorwheel. PAY ATTENTION: increasing this value you will take more overheating risk on the motor.

Parameters which can be set through programming port J9					
Code	Description	Min. values	Default values *	Max. values	Meaning
IMAX	Drive system maximum current (A)	10	80	100	It is the max instantaneous current that is possible to supply to the drive motorwheel. PAY ATTENTION: increasing this value you will take more overheating risk on the motor
TMAX	Protection intervention time for IMAX (s)	0	15	60	It is the time reaction of the drive motorwheel overloading protection: this parameter is used in combination with IMAX to have the right response time curve of the drive motor overloading protection system. PAY ATTENTION: increasing this value you will take more overheating risk on the motor
AMAX	Maximum lateral acceleration (g/100)	1	15	100	It is the max side acceleration allowed to the machine. Over this value the drive system will cut the power to the motorwheel in order to maintain the machine stability. PAY ATTENTION: increasing this value you will take more tipping risks
KG	Lateral acceleration control constant	1.0	1.6	2.0	Engineering parameter related to AMAX. - Do not modify.
WSMIN	Minimum driving speed	0	15	100	Maximum speed % setting driving speed on 1 (minimum = 1 LED on)
WSMAX	Maximum driving speed	0	100	100	Maximum speed % setting driving speed on 4 (maximum = 4 LEDS on)

(*) The default value is stored in the electronic board by the manufacturer.

Removal and Installation

Display Electronic Board and Dashboard Electronic Board Replacement

Display Electronic Board Disassembly

1. Drive the machine on a level floor.
2. Turn the ignition key to “0” and disconnect the batteries.
3. Remove the steering wheel height control lever (A).
4. Lift the cover (B) and remove the seeger (C), then remove the steering wheel assembly (D).
5. Lift the covers and unscrew the screws (E), then lift the dashboard assembly (F).
6. Disconnect the connector (G) from the ignition key and the connector (H) from the electronic board.
7. Disconnect the flat connectors (I) of the dashboard electronic board.
8. Unscrew the nuts (J), recover the spacers and remove the display electronic board (K).

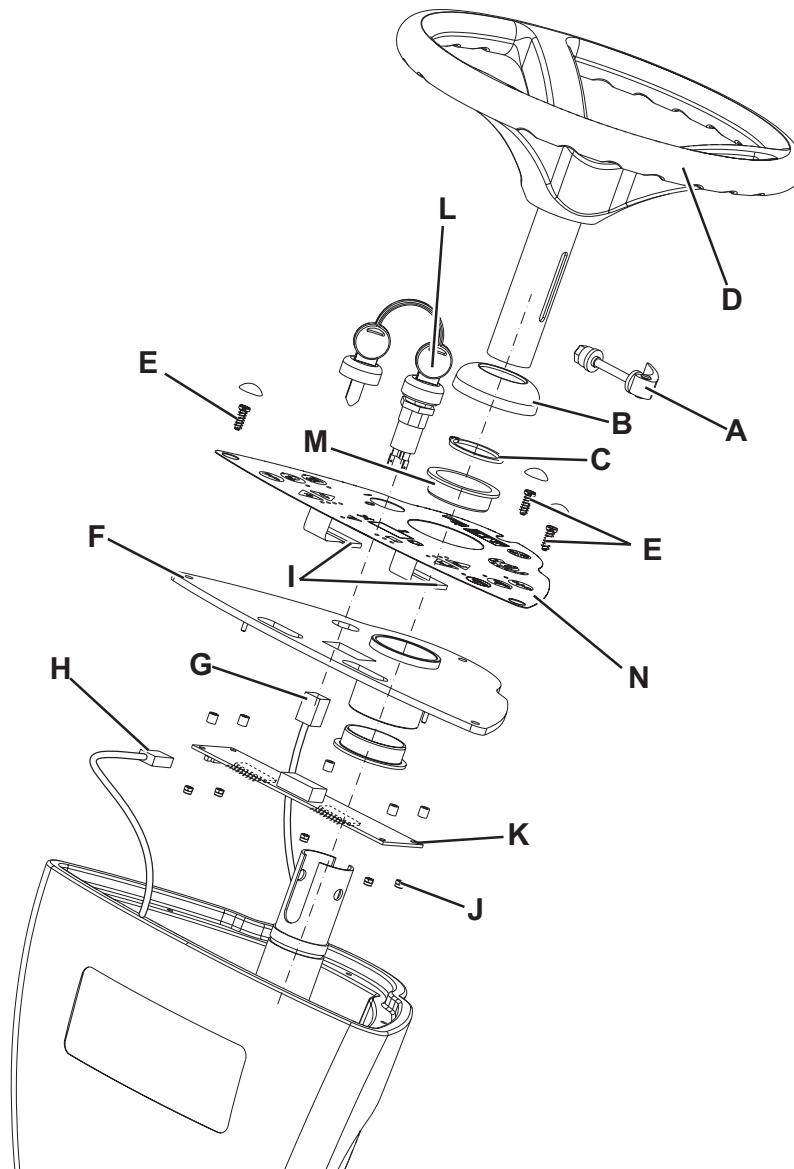

Display Electronic Board and Dashboard Electronic Board Replacement (continued)

Dashboard Electronic Board Disassembly

9. Perform steps 1 to 7 of the display electronic board disassembly.
10. Remove the ignition key (L).
11. Remove the bush (M).
12. Carefully lift and remove the dashboard electronic board (N) from the plate (F).

Assembly

13. Assemble the components in the reverse order of disassembly, and note the following:
 - Install the dashboard electronic board (N) by passing the flat connectors (I) into the slots of the plate (F), then carefully install it on the plate.

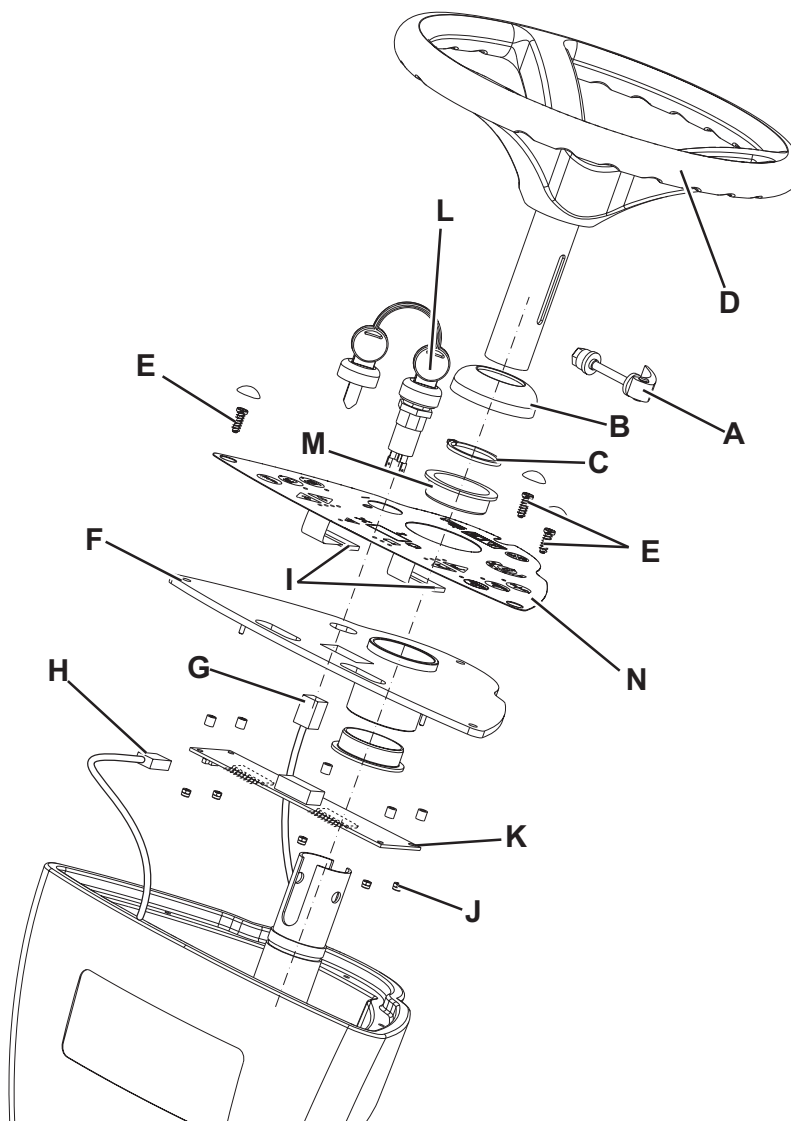

Function Electronic Board Lay-Out and Disassembly/Assembly

Disassembly

1. Drive the machine on a level floor.
2. Turn the ignition key to “0” and disconnect the batteries.
3. Lift the recovery tank assembly.
4. Remove the 6 screws and remove the electronic component compartment cover.
5. Remove the 2 mounting screws of the function electronic board assembly and carefully remove it from the housing.
6. Disconnect the following connections sequentially:
 - (A) and (B) Power supply connection (+) and (-).
 - (C and D) Driving wheel connection (M1) and (M2).
 - (E) Pressure switch module connection (J7A and J7B).

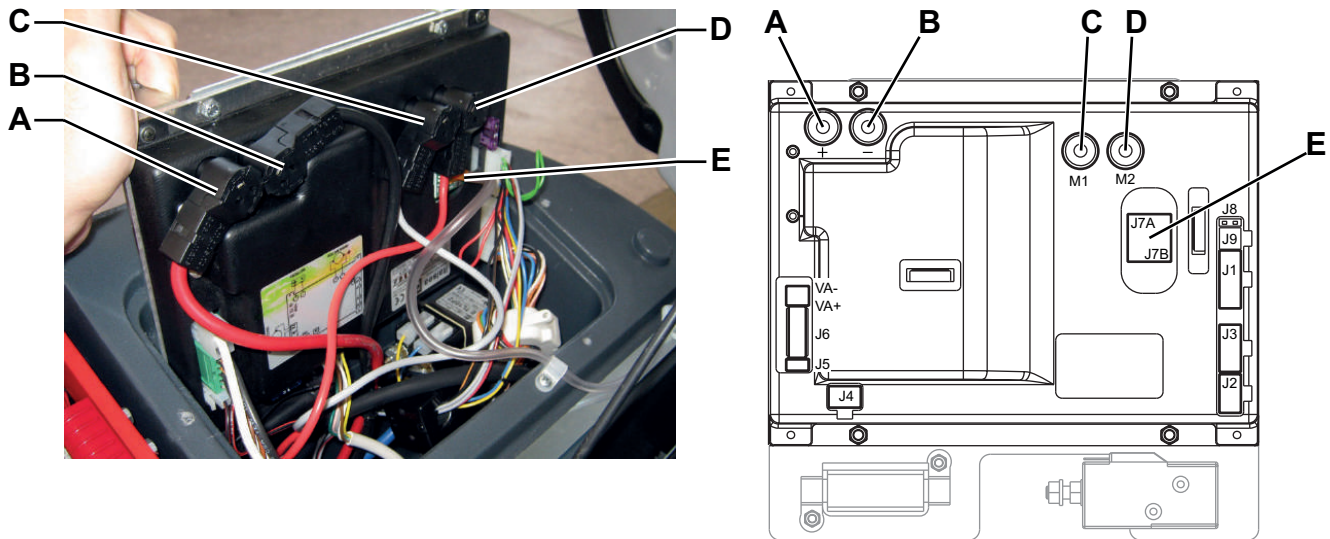

P100695



Warning! Do not try to remove the pressure switch module by pulling the transparent hose: the connection between the hose and sensor can be irretrievably damaged. Remove the module by forcing on the PCB as shown in the figure.

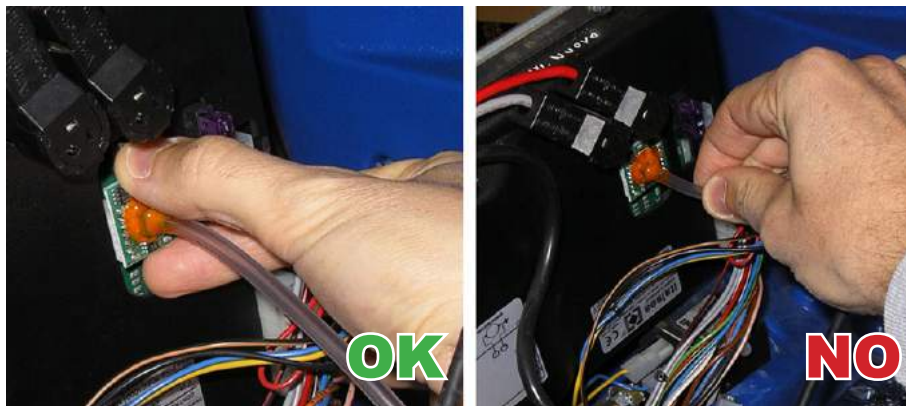

P100696

Function Electronic Board Lay-Out and Disassembly/Assembly (continued)

- (F) Electrical component wiring harness connection (J1).
- (G) Foot board wiring harness connection (J3).
- (H) Frame wiring harness connection (J2).
- (I) Vacuum system wiring harness connection (VA+ and VA-).

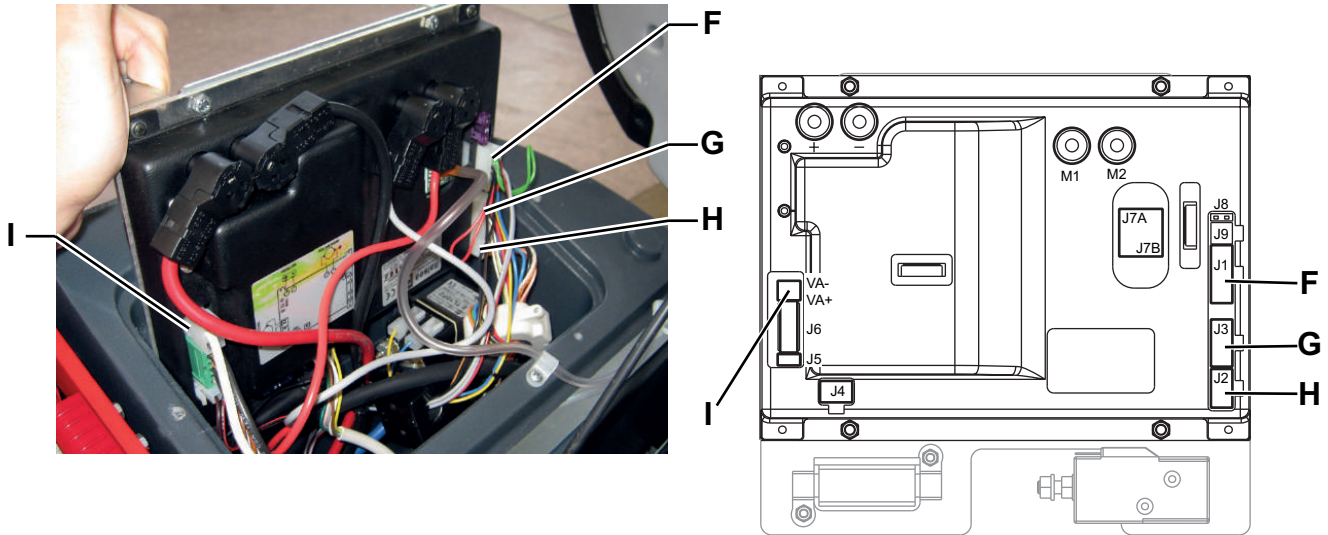

P100697

- (J) Recovery tank wiring harness connection (J6).
- (K) Electromagnetic brake wiring harness connection (J5).
- (L) Brush deck actuator wiring harness connection (J4).

7. Remove the function electronic board mounting screws (M) from the plate.

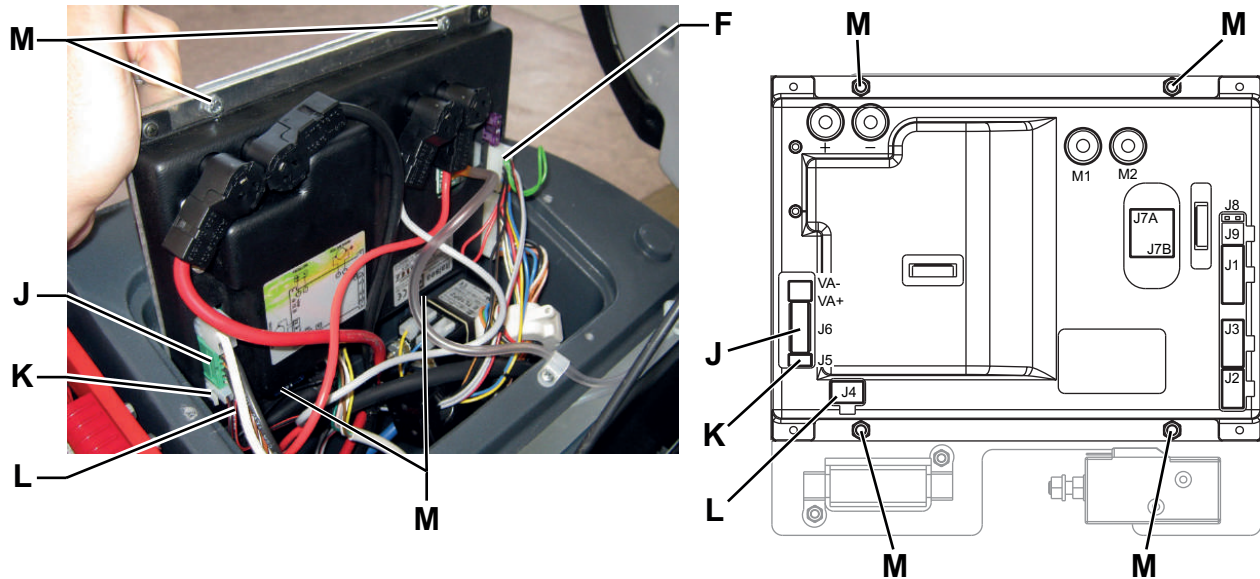

P100698

Assembly

8. Assemble the components in the reverse order of disassembly.

Specifications

Connectors on the function electronic board

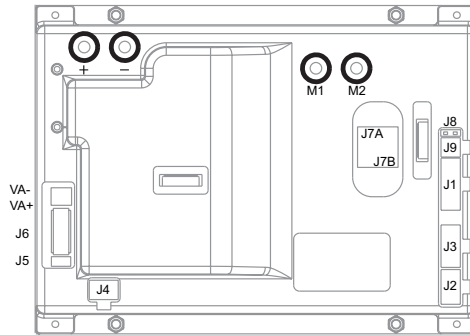

Power connections (male RADSOK terminals Ø6mm (AMPHENOL P/N N01 060 0001 1 or equivalent))					
Ref.	Description	Electronic board in/out	V ref.	I max.	Connected to
B+	Electronic board power supply +	in	24V	120A	BAT+
B-	Electronic board power supply -	in	24V	120A	BAT-
M1	Drive system motor +	out	24V	100A	M3+
M2	Drive system motor -	out	24V	100A	M3-

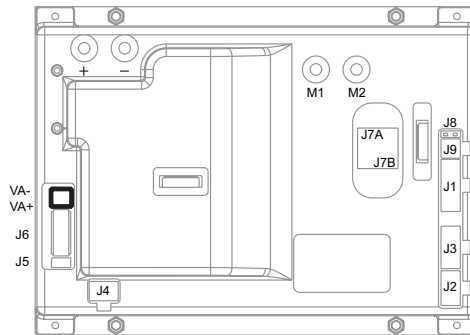

Vacuum system connections (2-ways male faston 6.3x0.8 – pitch 6.5mm)					
Ref.	Description	Electronic board in/out	V ref.	I max.	Connected to
VA+	Vacuum system power supply +	out	0V	30A	M2+
VA-	Vacuum system power supply -	out	10-24V	30A	M2-

Connectors (continued)

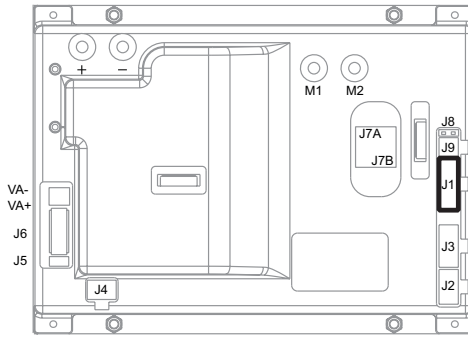

J1: MOLEX MINIFIT type, 12-ways vertical					
PIN	Description	Electronic board in/out	V ref.	I max.	Connected to
1	Brush electromagnetic switch power supply +	out	24V	<1A	ES1
2	Brush electromagnetic switch power supply -	out	0V	<1A	ES1
3	Brush fuse voltage drop reading +	in	0V	<1A	F1
4	Brush fuse voltage drop reading -	in	0V	<1A	F1
5	Power supply for N/A version configurator	out	0V	<1A	J1.6
6	N/A version configurator return	in	0V	<1A	J1.5
7	Power supply for deck configurator	out	0V	<1A	J1.8
8	Deck configurator return	in	0V	<1A	J1.7
9	Consent for battery charger	out	24V	<1A	CH.1
10	Enabling from battery charger	in	24V	<1A	CH.2
11	Battery charger data communication slot	in/out	5V	<1A	CH.3
12	Auxiliary power supply + (under key)	out	24V	<1A	-

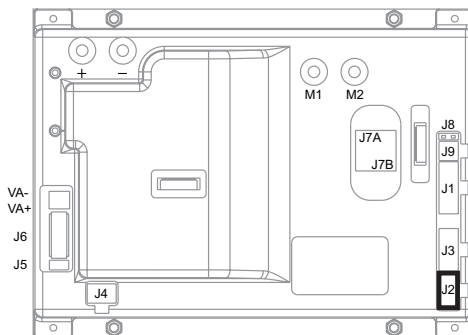

J2: MOLEX MINIFIT type, 8-ways vertical					
PIN	Description	Electronic board in/out	V ref.	I max.	Connected to
1	Solenoid valve power supply +	out	24V	1A	EV1
2	Solenoid valve power supply -	out	0V	1A	EV1
3	Detergent pump power supply +	out	24V	<1A	M4
4	Detergent pump power supply -	out	0V	<1A	M4
5	Buzzer power supply +	out	24V	<1A	BZ1.+ / PR1+
6	Buzzer power supply -	out	0V	<1A	BZ1.cont
7	Auxiliary power supply + (under key)	out	24V	<1A	-

8	Auxiliary power supply -	out	0V	<1A	-
---	--------------------------	-----	----	-----	---

Connectors (continued)

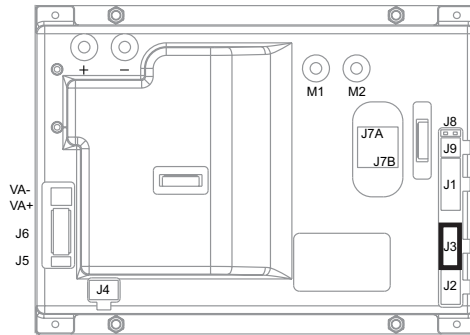

J3: MOLEX MINIFIT type, 10-ways vertical					
PIN	Description	Electronic board in/out	V ref.	I max.	Connected to
1	Dashboard power supply +	out	24V	<1A	EB2.1
2	Dashboard serial +	in/out	5V	<1A	EB2.2
3	Dashboard serial -	in/out	0V	<1A	EB2.3
4	Dashboard power supply -	out	0V	<1A	EB2.4
5	Power supply for key circuit	out	24V	<1A	K1
6	Return from key	in	24V	<1A	K1
7	Pedal potentiometer power supply +	out	5V	<1A	RV1.F
8	Pedal potentiometer return -	In	0-5V	<1A	RV1.E
9	Pedal potentiometer power supply -	out	0V	<1A	RV1.D
10	-				

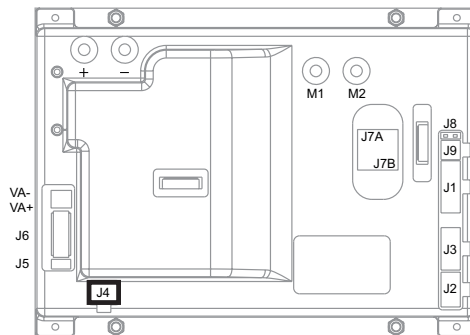

J4: MOLEX MINIFIT type, 6-ways vertical					
PIN	Description	Electronic board in/out	V ref.	I max.	Connected to
1	Actuator power supply - microswitch	out	0V	<1A	M5.m0,1,2
2	Return from microswitch actuator m0	in	0V	<1A	M5.m0
3	Return from microswitch actuator m1	in	0V	<1A	M5.m1
4	Return from microswitch actuator m2	in	0V	<1A	M5.m2
5	Deck actuator power supply +/-	out	0/24V	8A	M5
6	Deck actuator power supply -/+	out	0/24V	8A	M5

Connectors (continued)

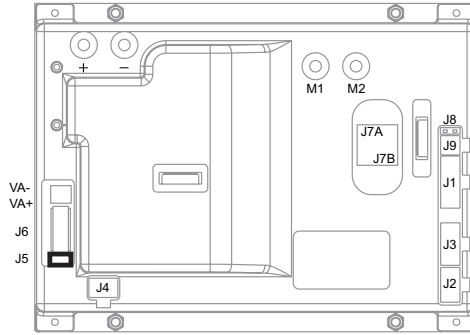

J5: MOLEX MINIFIT type, 2-ways vertical

PIN	Description	Electronic board in/out	V ref.	I max.	Connected to
1	Driving wheel brake power supply +	out	24V	1A	BRK
2	Driving wheel brake power supply -	out	0V	1A	BRK

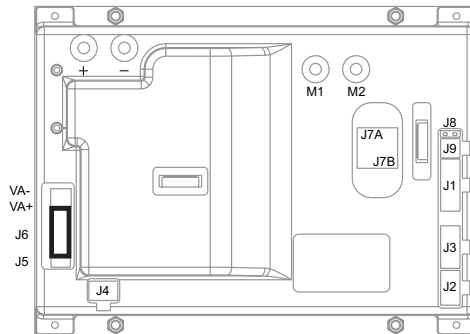

J6: TYCO MODU1 type, 6-ways vertical

PIN	Description	Electronic board in/out	V ref.	I max.	Connected to
1	Squeegee actuator power supply +/-	out	0/24V	8A	M6
2	Squeegee actuator power supply -/+	out	0/24V	8A	M6
3	Flashing light power supply +	out	24V	<1A	BE
4	Lamp / seat microswitch / float power supply -	out	0V	<1A	BE / SW1,2
5	Return from driver's seat microswitch	in	0V	<1A	SW1
6	Return from float	in	0V	<1A	SW2

Connectors (continued)

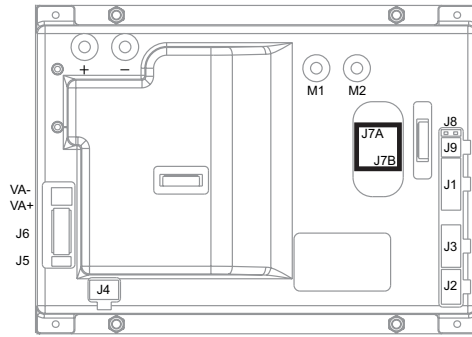

J7: PRESSURE SWITCH connector, Berger type, 3+3-ways vertical ()

A1	Pressure switch power supply +	out	5V	<1A	Press.A1
A2	Pressure switch power supply -	out	0V	<1A	Press.A2
A3	-	-	-	-	Press.A3
B1	-	-	-	-	Press.B1
B2	Pressure switch signal +	in	0-5V	<1A	Press.B2
B3	Pressure switch signal -	in	0V	<1A	Press.B3

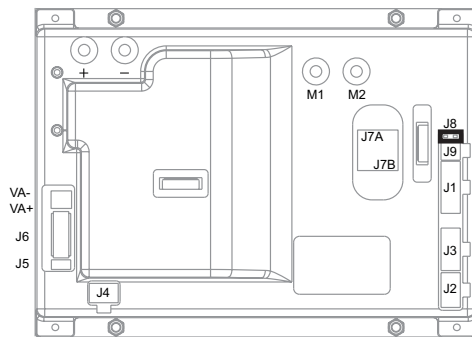

J8: JUMPER, 2-ways vertical

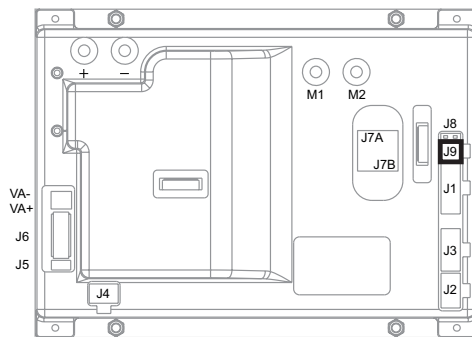

J9: MOLEX MINIFIT type, 4-ways vertical

Connector for parameter programming

Electrical System

Functional Description

The batteries (two 12V or four 6V) are connected in series by bridge cables.

The battery charger (CH) is connected to the machine by two connectors (C) (power connection to the batteries) and C3 (3-way signal connection). The grey cables (terminals 1 and 2 of connector C3) are short-circuited in battery charger CH when it is not connected to the electrical mains. If this connection is not made, all machine functions are disabled.

If the optional battery charger has not been installed, the relevant bridge must be used on connector C3.

The yellow cable (terminal 3 of connector C3) is the data cable between board EB1 and battery charger CH. This connection is used to set battery charger charging curves directly on the machine dashboard (see User Manual) and displays the state of the battery charger when charging, on the 3 battery dashboard LEDs:

Red LED lit = main charging phase

Yellow LED lit = equalization phase (charge completion)

Green LED lit = charging phase successfully completed

Wiring Diagram

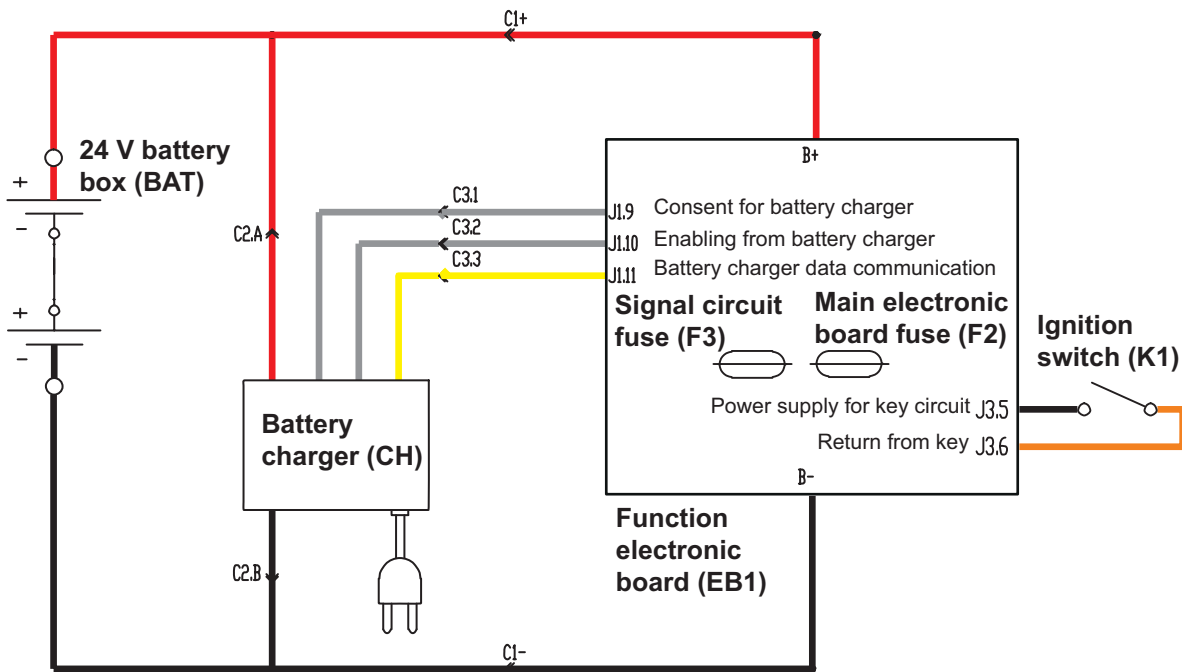

Component Location

- Batteries (BAT)
- Battery connections
- Battery charger (CH)
- Electrical panel
- Battery connector (C1)
- Function electronic board (EB1)

Battery charger (CH)

Battery connector (C1)



Batteries (BAT)

Battery connections

P100700

Electrical panel

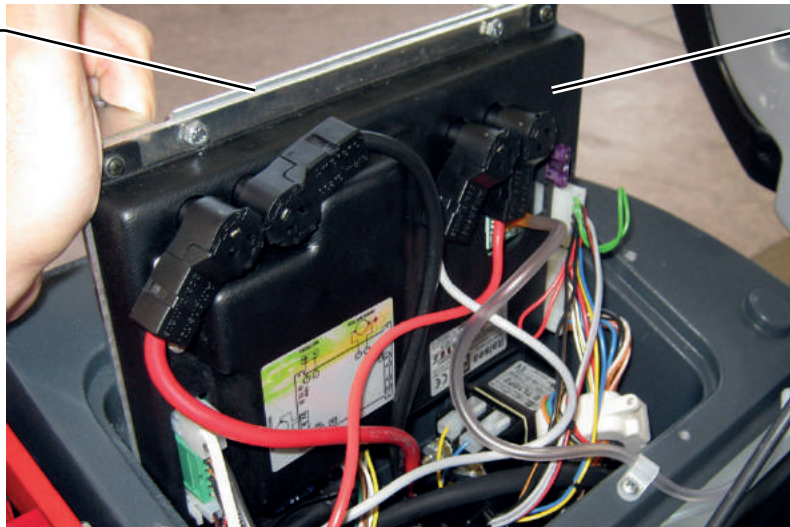

Function electronic board (EB1)

P100701

Maintenance

Charge condition display

	INDICATION	TRANSITION THRESHOLD (VOLT)		CONSEQUENCE
		WET	GEL	
1	GREEN LED: fixed - YELLOW LED: fixed	22 V	22.2 V	-
2	YELLOW LED: fixed - RED LED: flashing	20.4 V	21.6 V	Brushes OFF
3	Safety threshold	19.4 V	20.6 V	Vacuum system OFF
4	Drive threshold	18.4 V	19.6 V	Drive system OFF

Fuse and Electromagnetic Switch Check/Replacement

1. Drive the machine on a level floor.
2. Turn the ignition key to “0” and disconnect the batteries.
3. Remove the screws and remove the electronic component compartment cover.
4. Remove the mounting screws of the function electronic board assembly and remove it from the housing.
5. Check/replace the following fuses:
 - (F1) 50A fuse - Brush motors.
 - (F2) 100A MIDI fuse - Function electronic board (drive and vacuum system).
 - (F3) 3A blade fuse - Signal circuit.
 - (F4) 15A blade fuse - Deck and squeegee lifting actuator.
6. Further move the function electronic board assembly to remove the electromagnetic switch (ES1).
7. Place the function electronic board assembly in its housing, tighten the mounting screws and install the electronic component compartment cover.

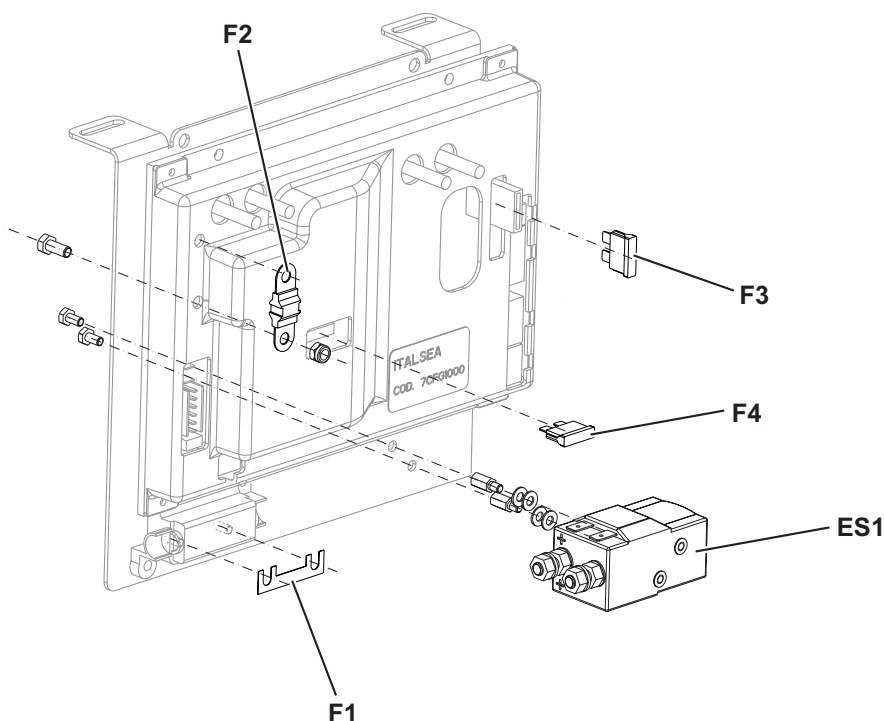

Troubleshooting

See the other chapters related to the use of the electrical system.

Trouble	Possible Causes	Remedy
The machine is not working	The batteries (BAT) are discharged or its connections are not efficient	Charge the batteries or clean the connections
	The batteries (BAT) are broken	Check the battery no-load voltage
	The battery charger (CH) is broken	Replace
	The fuses (F2, F3) are open	Replace
	The wiring harness is cut or pressed or short circuited	Repair
	The ignition key (K1) does not work	Replace



Note:

A damage to the battery charger or its connections can prevent the machine from operating properly.

General Wiring Diagram

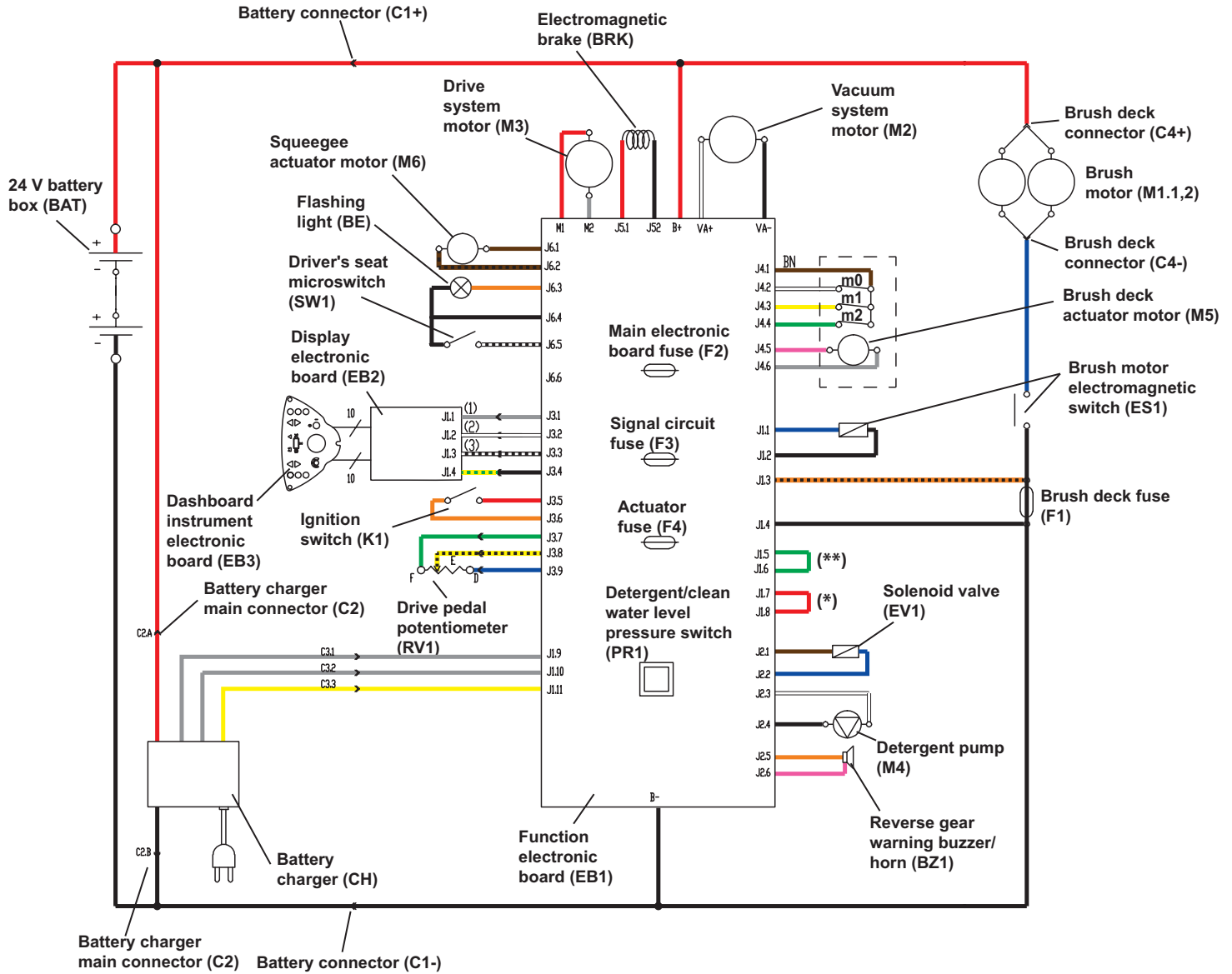

(*) Only for versions with disc brush deck
 (**) For Nilfisk-Alto scrubbers version only

Specifications

Battery compartment size (length x width x height)		14.9 x 21.2 x 11.8 in (380 x 540 x 300 mm)
Battery type		4 6 V batteries, 180 Ah C5 (WET)
		4 6 V batteries, 180 Ah C5 (GEL/AGM)
Standard batteries autonomy (capacity)		2.5 - 3.5 hours
Battery charger	Model	24V 25A
	Input voltage	85Vac+264Vac, 50Hz+60Hz
	Charging procedure	by microprocessor
	Efficiency	> 85%
	Environmental protection class	IP66
	Maximum input current	15Arms
Total machine electrical input		60 A

Recovery System

Functional Description

The water recovery system removes the dirty water from the floor and pipes it to a recovery tank. When the machine is running, the dirty water on the floor is collected by the squeegee blades and collected through the slots in the same, piped through the vacuum hose and into the tank by the airflow created by Vacuum system motor (M2). The dirty water is piped into the recovery tank, while the airflow continues to the vacuum fan. A tank with a screen collects the largest debris going through the recovery tank hose. The automatic float in the vacuum screen stops Vacuum system motor (M2) from collecting any liquids. When the automatic float closes and shuts down the vacuum system, the vacuum system motor noise will increase and the floor will not be dried.

When the recovery tank is full it can be emptied through the drain hose.

Wiring Diagram

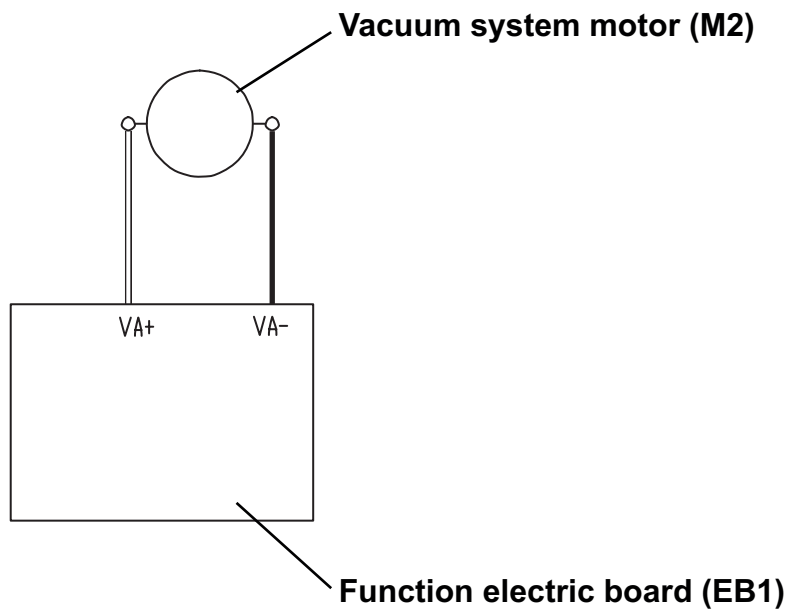

Component Location

- Recovery tank
- Recovery tank cover
- Gasket cover
- Container with debris collection grid
- Float ball and cage
- Vacuum system motor (M2)
- Squeegee vacuum hose
- Recovery water drain hose
- Vacuum system wiring harness connection
- Function electronic board (EB1)



P100705

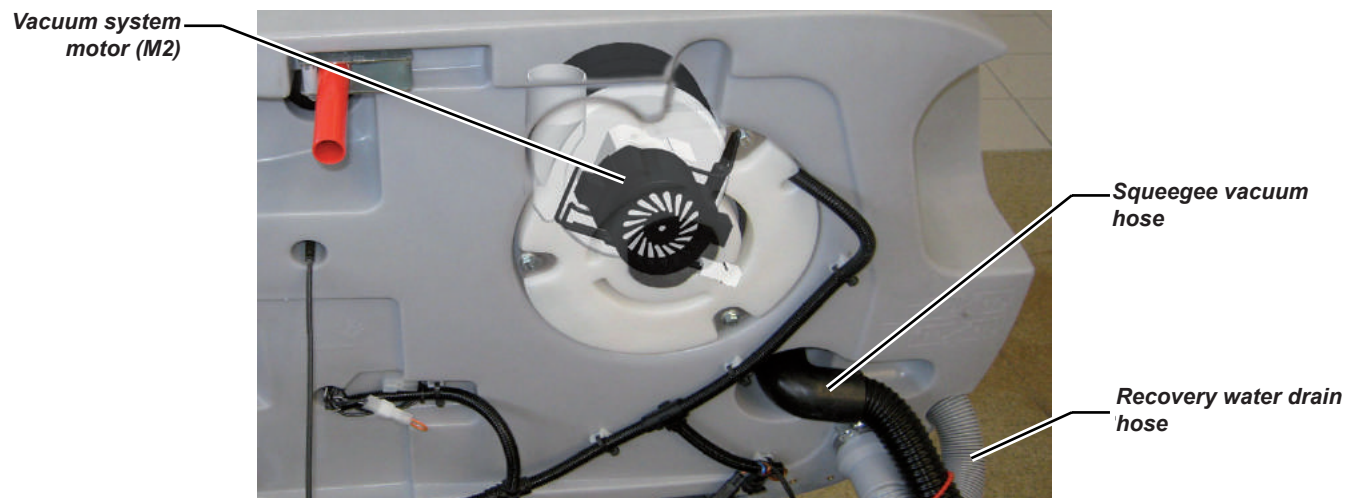

P100706

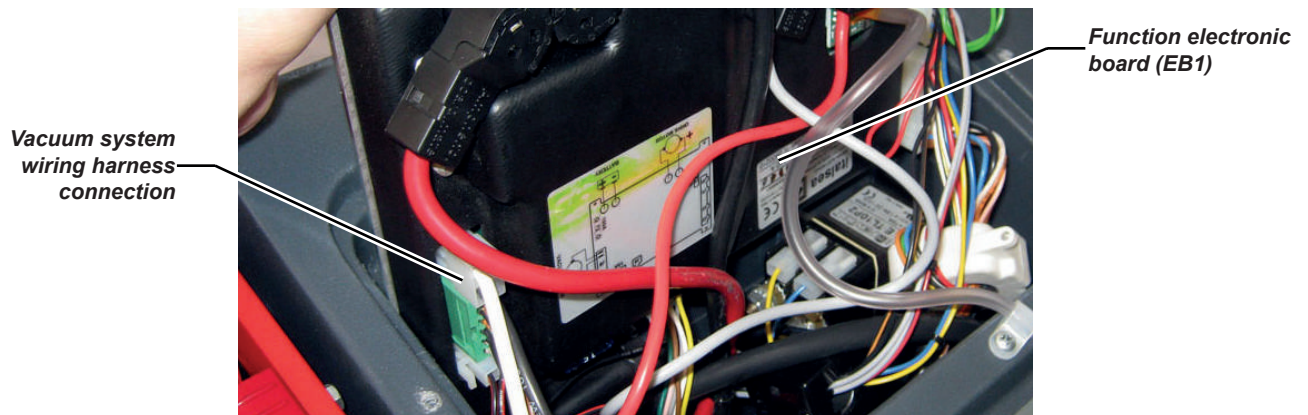

P100707

Maintenance and Adjustments

Recovery Tank Cleaning

1. Drive the machine to the appointed disposal area.
2. Turn the ignition key to “0”.
3. Open the recovery tank cover.
4. Clean and wash the cover and the recovery tank with clean water.
5. Empty the recovery tank with the drain hose.
6. Clean the vacuum grid, release the fasteners (A), open the grid (B) and recover the float (C) then clean carefully and reinstall.
7. Clean the container with debris collection grid (G), remove the container, remove the cover (H), then clean carefully and reinstall the vacuum hose.
8. Check the tank cover gasket (D) for integrity.



Note: The gasket (D) creates vacuum in the tank that is necessary for vacuuming the recovery water.

9. If necessary replace the gasket (D) by removing it from its housing (E). When assembling the new gasket, install the joint (F) in the lower area, as shown in the figure.
10. Check that the seating surface (I) of the gasket (D) is integral, clean and adequate for the gasket itself.
11. Close the recovery tank cover.

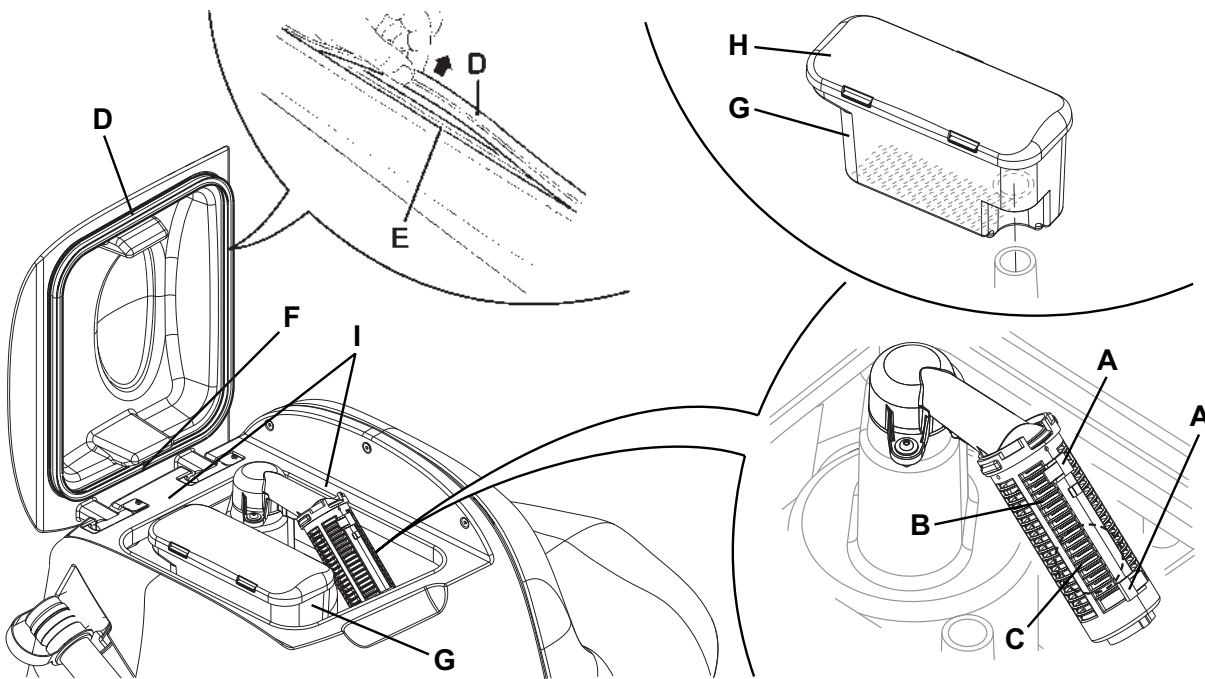

Troubleshooting



Trouble	Possible Causes	Remedy
The vacuum system motor does not turn on	The wiring harness between function electronic board (EB1) and vacuum system motor (M2) is damaged	Repair
	The vacuum system motor carbon brushes are worn	Replace
	The dashboard instrument electronic board (EB3) is faulty	Replace
	The vacuum system motor is faulty	Check the electrical input
Dirty water vacuuming is insufficient or there is no vacuuming	The vacuum grid with automatic shut-off float is activated because the recovery tank is full	Drain the recovery tank
	The filter is dirty	Clean
	The vacuum grid with automatic shut-off float is dirty	Clean
	The tank cover is not correctly positioned	Adjust
	The tank cover gasket is not efficient	Clean or replace
	The vacuum system motor filter is dirty	Clean
	The vacuum gaskets are damaged or do not match perfectly	Repair or replace

Removal and Installation

Vacuum system motor electrical input check



Warning! This procedure must be performed by qualified personnel only.

1. Install an Amp clamp (A) on one cable (B) of the batteries.
2. Turn the ignition key to "I".
3. Turn on the vacuum system by pressing the vacuum system push button  and check that the motor electrical input is **16 - 19 A at 24 V**.
4. Turn off the vacuum system motor by pressing the vacuum system push button .
5. Remove the Amp clamp (A).
6. If the amperage exceeds the specifications, check the motor carbon brushes (see the procedure in the relevant paragraph).
7. If necessary, remove the vacuum system motor (see the procedure in the relevant paragraph), and check the condition of its moving parts.
8. If the above-mentioned procedures do not restore normal current draw, the motor must be replaced (see the procedure in the relevant paragraph).

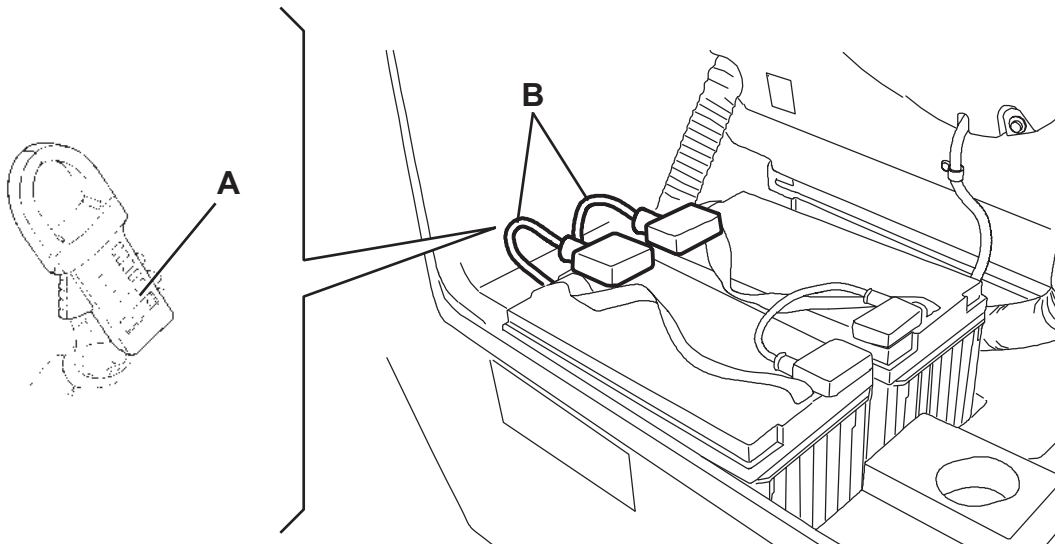

Vacuum System Motor Carbon Brush Check/Replacement

1. Remove the vacuum system motor (see the procedure in the following paragraph).
2. At the workbench, remove the screws and the cover (A) from the vacuum system motor (B).
3. Remove the screws (C).
4. Disconnect the electrical connections (D).
5. Remove the carbon brushes (E).
6. Check the carbon brushes (E) for wear. Replace the carbon brushes when:
 - The contact with the motor armature is insufficient
 - The carbon brushes are worn,
 - The carbon brush contact surface is not integral,
 - The carbon brush when the stroke residual is less than 0.12 in (3 mm),
 - The thrust spring is broken, etc.
7. If necessary, replace the carbon brushes. Replace the carbon brushes as an assembly.
8. Assemble the components in the reverse order of disassembly.

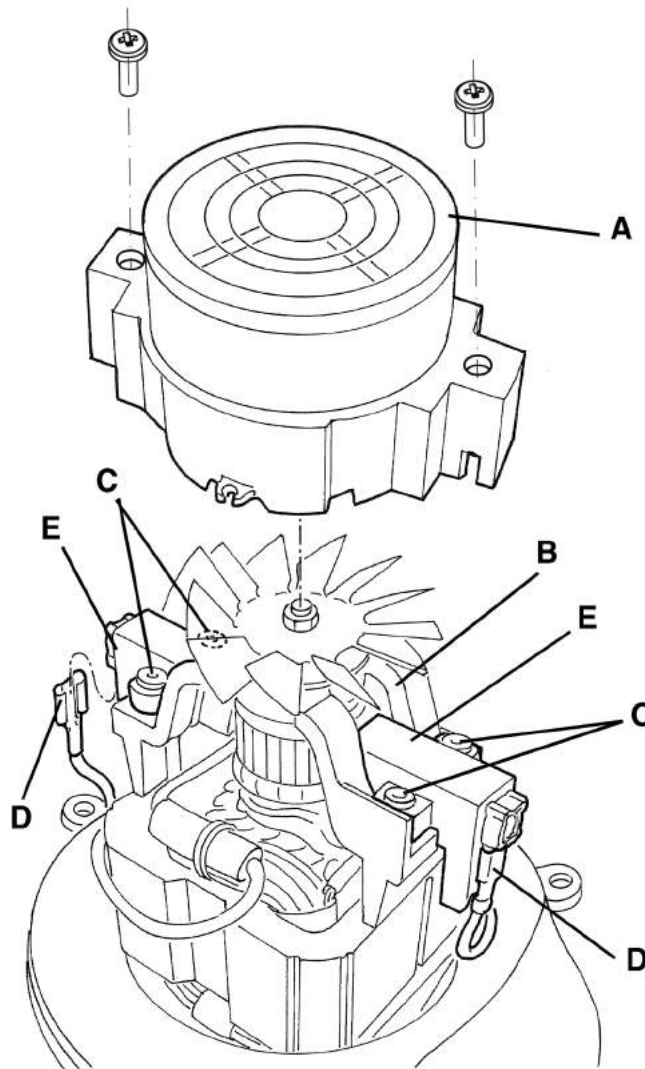

Vacuum System Motor Disassembly/Assembly

Disassembly

1. If there is recovery water in the tank, drain it.
2. Turn the ignition key to “0” and disconnect the batteries.
3. Lift the recovery tank assembly.
4. Remove the screws (A) and recover the washers.
5. Remove the motor cover (B).
6. Remove the filter (C) and the gasket (D).
7. Remove the motor (E) or (L), the sound-deadening pipe (F) and the sound-deadening panel (G).
8. Disconnect the connector (H) of the motor (E).
9. Check the efficiency of the gasket (I) and, if necessary, replace it.

Assembly

10. Assemble the components in the reverse order of disassembly.

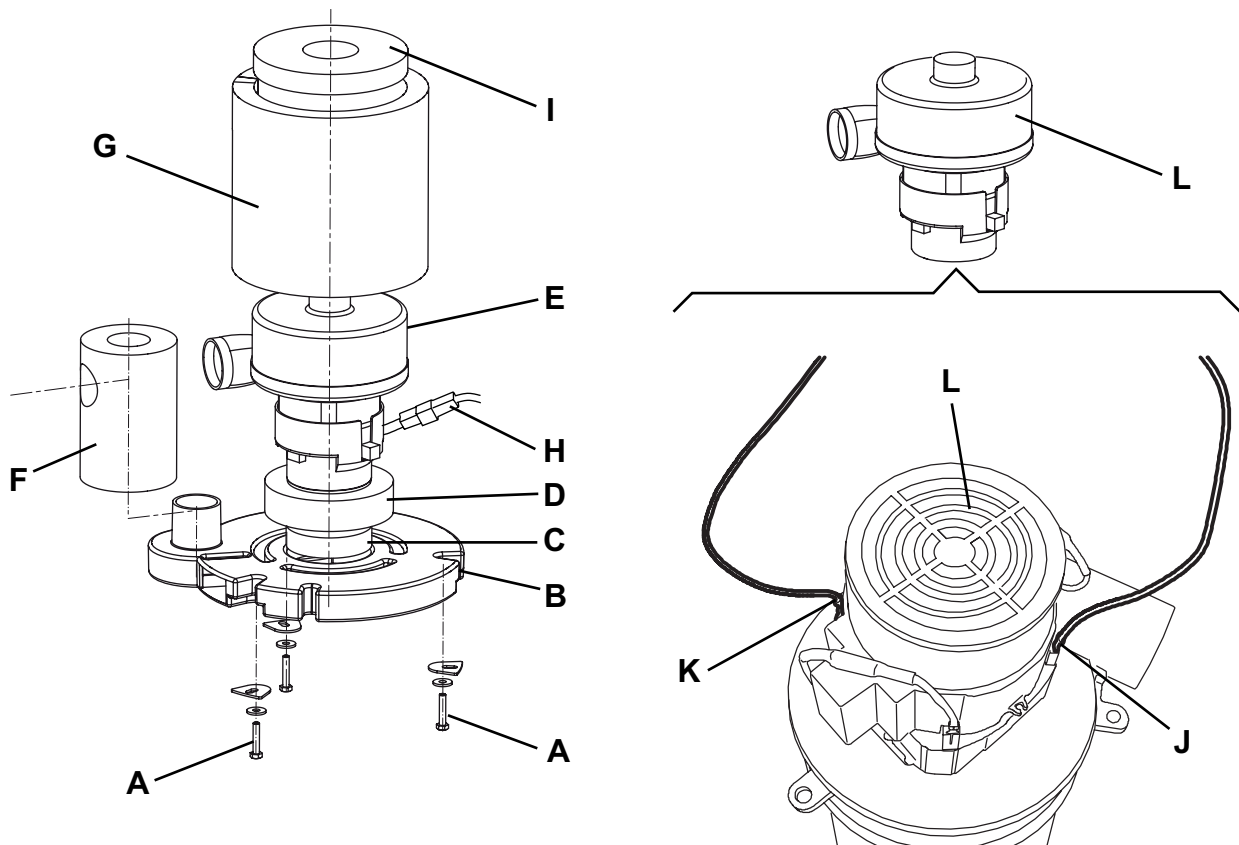

Specifications

Description	SCRUBTEC R 466 - FOCUS II Micro Rider 26D	SCRUBTEC R 471	SCRUBTEC R 471C	SCRUBTEC BOOST® R4 - FOCUS II Micro Rider 28 BOOST
Recovery tank capacity	21 US gal (80 L)			
Vacuum system motor technical data	0.56 hp (420 W)			
	20.8A VDC 24V			
	14900 rpm			
	0.0146 MPa (1,448 mmH ₂ O) (Blocked)			
	26.1 l/sec			
Vacuum performance	0.0098 MPa (1,000 mmH ₂ O) (Blocked)			

Scrub System, Cylindrical

Functional Description

The cylindrical brush system can be started by the operator.

The cylindrical brushes turn in opposite directions towards the centre of the deck.

The rotating brush system cleans the surface of the floor. The deck, where brushes suitable for cleaning the particular type of floor are installed, is the main part of the brush system.

The brush deck is mounted on a “magic deck” pantograph system with an electrical actuator. The “magic deck” system also traverses the deck to the side if it collides with an obstacle.

The electrical actuator, with limit microswitches, lifts and lowers the deck. The operating and washing pressure depends on the weight of the deck. The cylindrical brush system does not have extra pressure function.

The brushes rotate when the brush motors are activated by the function electronic board when the pedal is pressed.

The cylindrical brushes are driven by a belt and pulley transmission system.

The brush system uses the solution to wash the floor.

The 2 side skirts direct the washing water towards the rear squeegee.

There is also a removable box on the deck where the debris cleaned by the brushes collects.

In case of brush motor overload, a safety system stops the brushes after about one minute of continuous overload. The overload is shown by the three battery warning leds flashing simultaneously.

The overload is detected monitoring the sum of current flow on the motors. The current is measured by a voltage drop verification across the brush system fuse (F1). If the voltage drop become over the value stored in the “VS2” parameter (default = 70 mV), the 3 battery leds start flashing simultaneously and if the overload persist, after a variable delay depending on the overload amount, the motors will stop.

To start scrubbing again after a brush stop due to an overload, stop the machine by turning the ignition key to “0”. Turn on the machine by turning the ignition key to “I”.

In summary, the brush motor running needs the following conditions/inputs:

- Seat microswitch closed
- Brushes function enabled
- Drive pedal pressed
- Battery level not in red light blinking condition.

Wiring Diagram

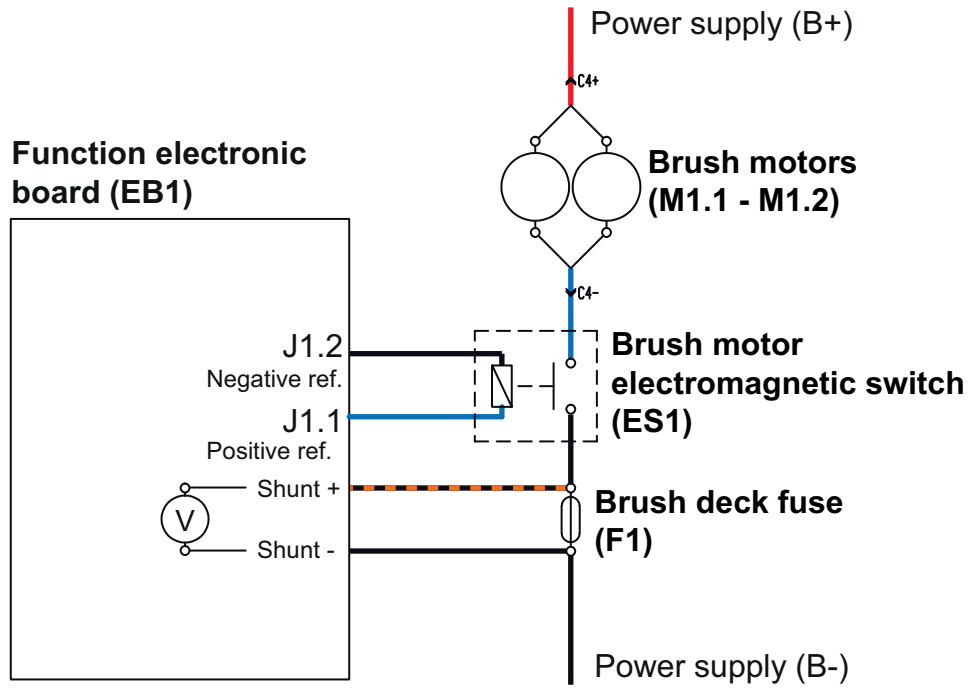

P100712

Actuator Wiring Diagram

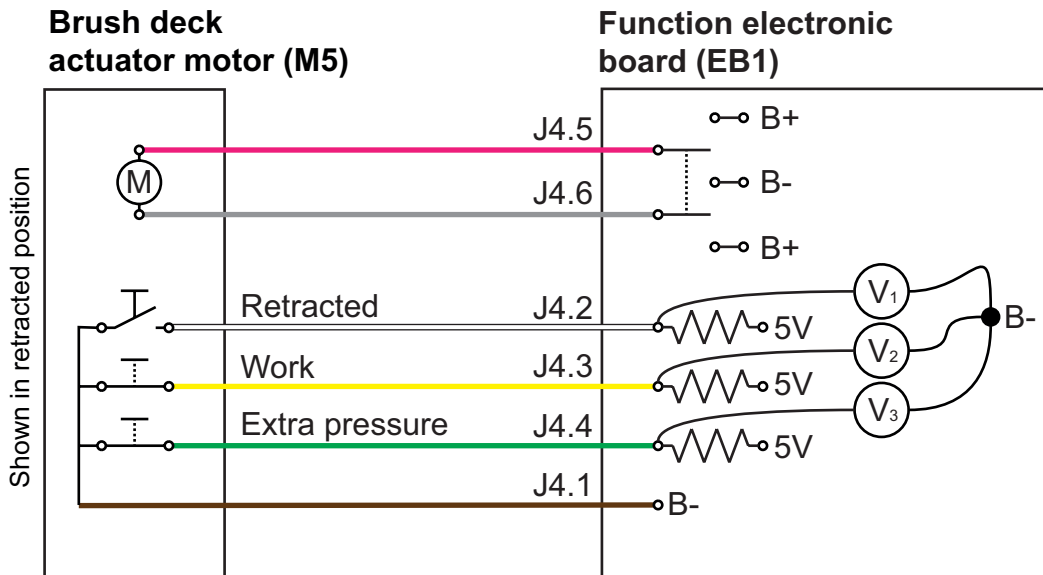

P100713

Voltage reference	Actuator position		
	Retracted	Work	Extrapressure
V ₁	5V	0V	0V
V ₂	0V	5V	0V
V ₃	0V	0V	5V

Component Location

- Cylindrical brush deck
- Debris container
- Side skirts
- Crankcase belt protection
- Front deck protection
- Motor pulley
- Roller belt tensioner
- Driving belt
- Brush pulley
- Support brush

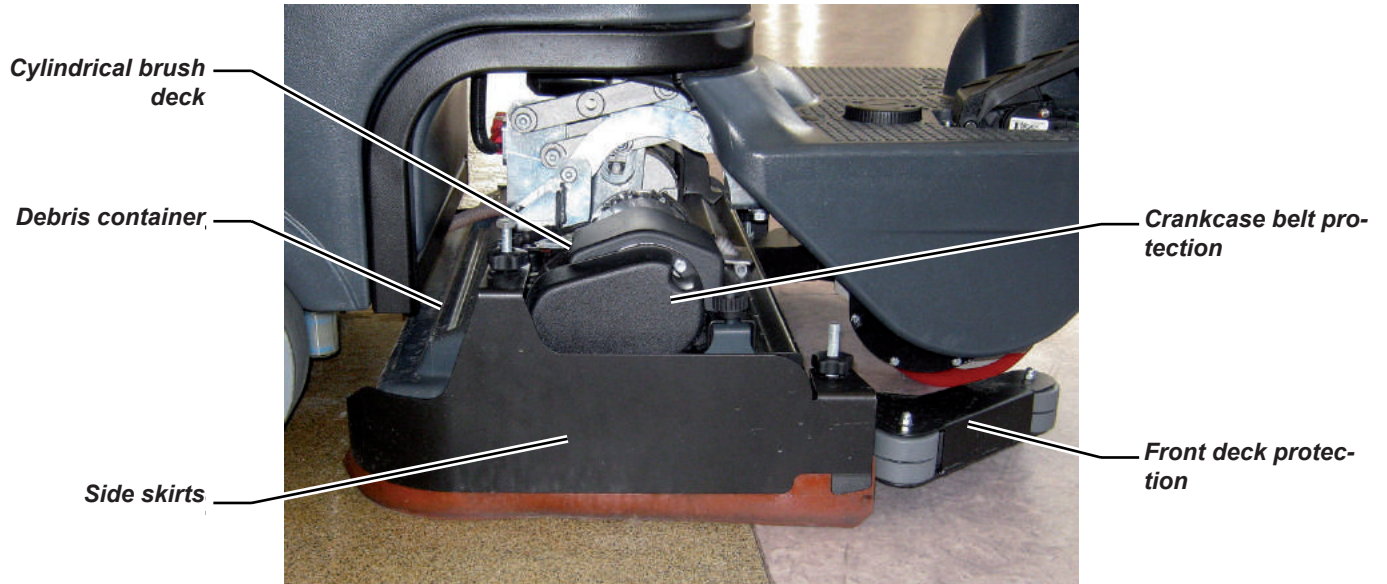

P100714

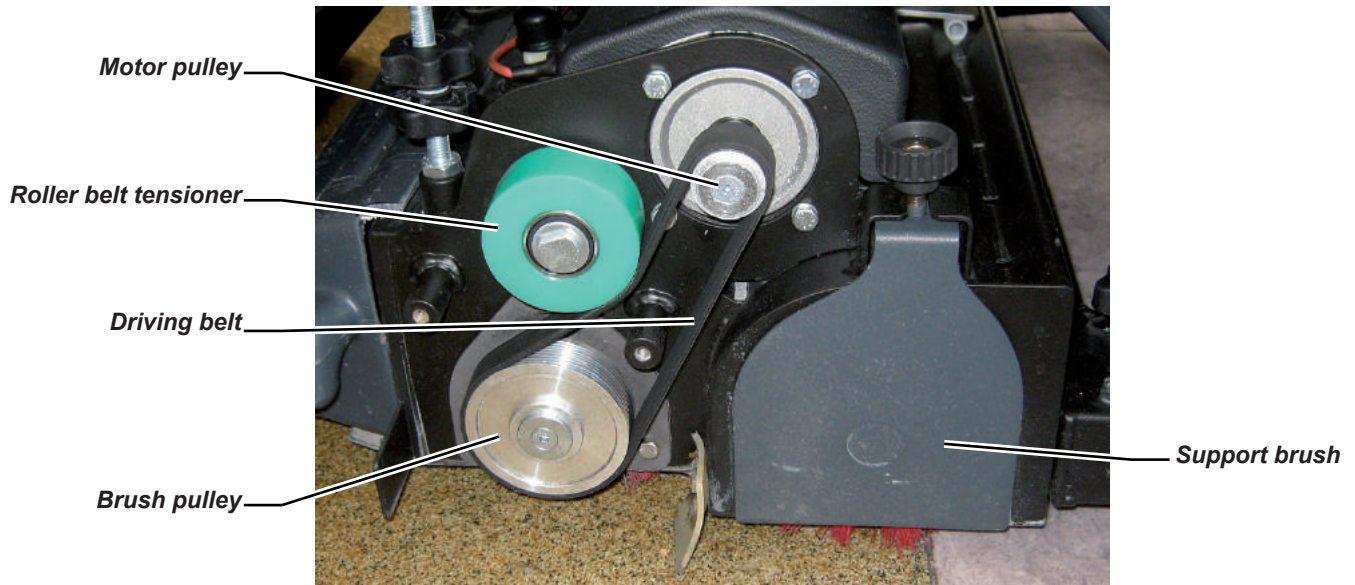

P100715

Component Location (continued)

- Brush deck lifting/lowering actuator
- Brush motor electromagnetic switch (ES1)
- Brush motor (M1.1 - M1.2)
- Function electronic board (EB1)
- Brush deck fuse (F1)
- Actuator system wiring harness connection

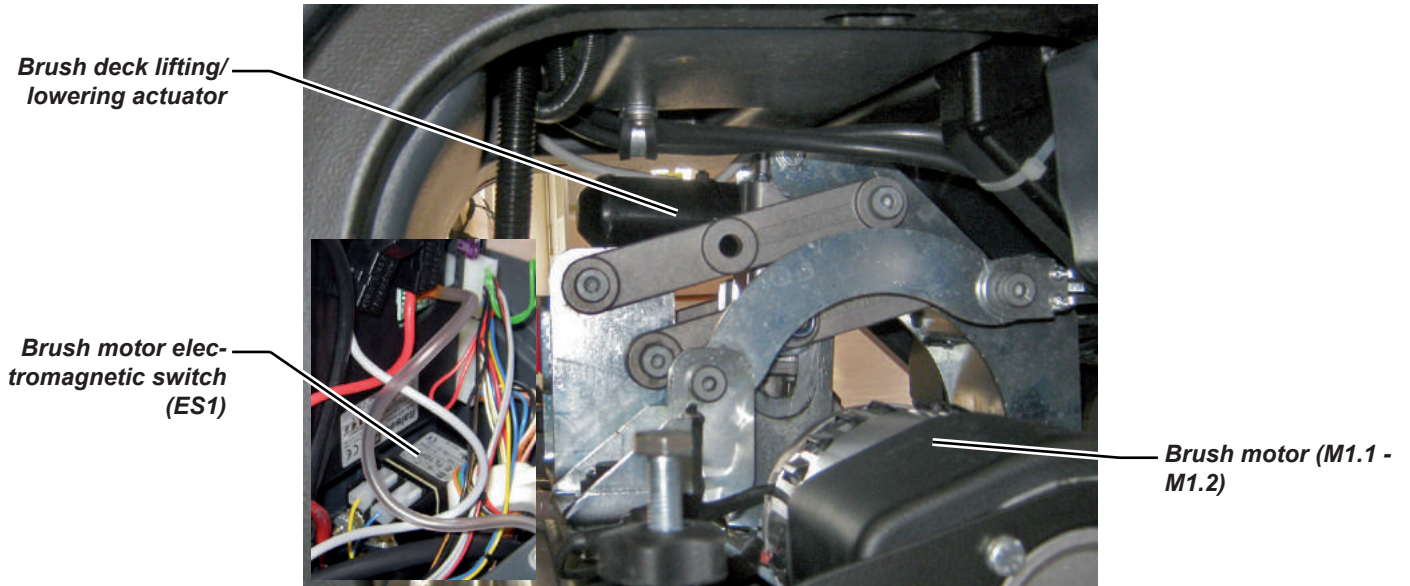

P100716

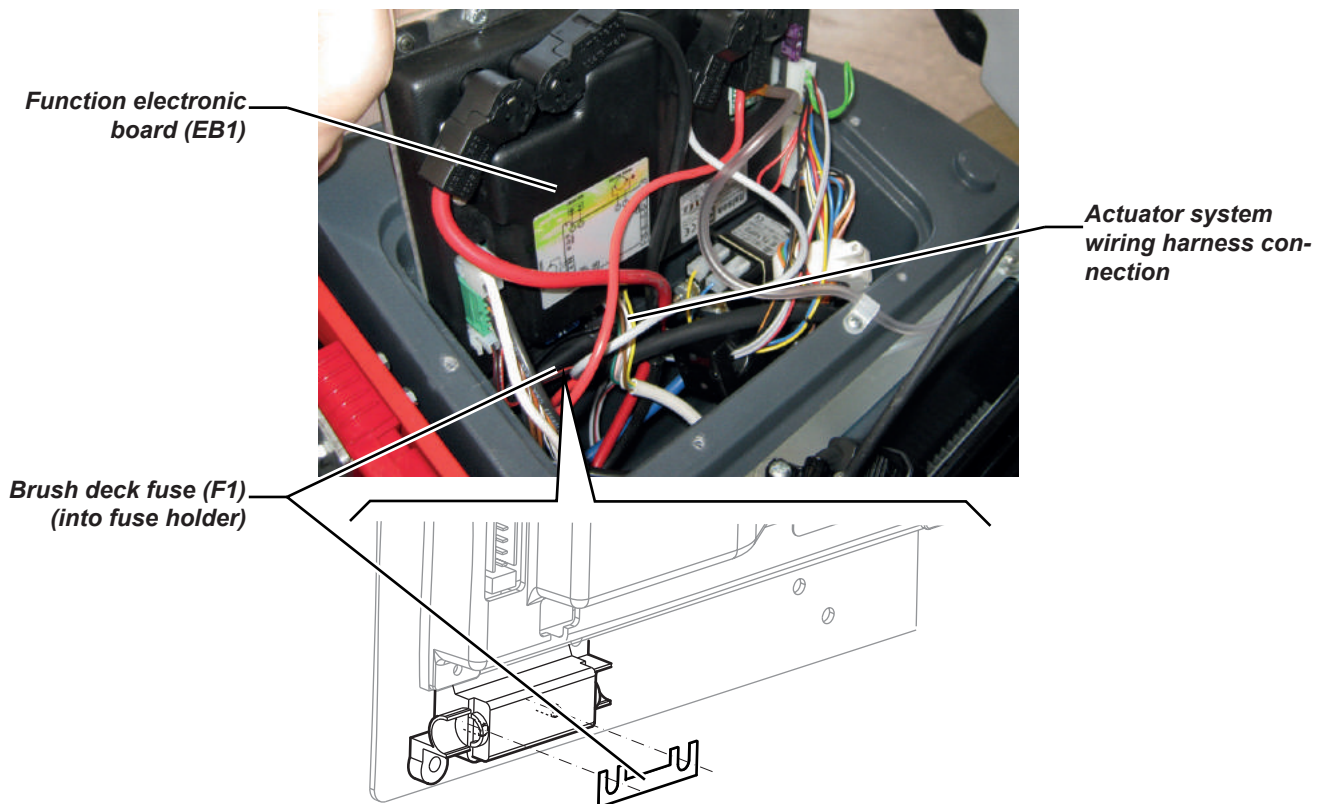

P100717

Maintenance and Adjustments

Cylindrical brush installation/removal

1. Insert the ignition key and turn it to “I”.



Warning! Before pressing the scrub On/Off push button , always check that, between the deck and the machine there is no foreign material which may prevent the deck from lifting.

2. Lift the deck by pressing the scrub On/Off push button .
3. Turn the ignition key to “0” and remove it.
4. On both sides of the machine, loosen the knobs (A) and remove the side skirt assemblies (B).
5. Unscrew the knobs (C) and remove the lids (D) by pushing the knobs downwards.
6. Install the cylindrical brushes (E), or remove them to install new ones.
7. The cylindrical brushes must be installed on either sides.
8. Install the lids (D) and fasten them with the knobs (C).
9. Install the side skirt assemblies (B), fasten them with the knobs (A).



Warning! If the machine is not perfectly assembled it can cause damages to people and properties. Always check that all components are assembled before starting the machine. Carefully inspect the machine before using it.

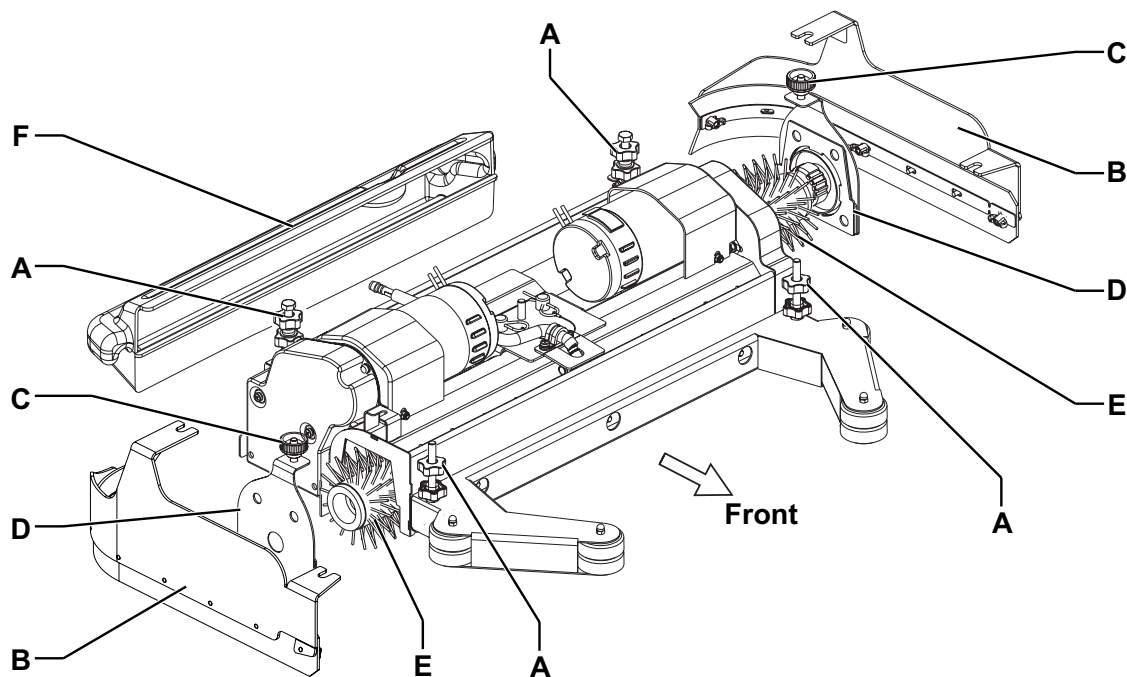

Side skirt check and replacement

Check

1. Drive the machine on a level floor.
2. Turn the ignition key to "0".
3. On both sides of the machine, loosen the knobs (A) and remove the side skirt assemblies (B).
4. Wash and clean the skirt.
5. Check that the skirt lower edge (C):
 - Lays down on the same level, along all its length;
 - Is integral and free from cuts and lacerations;
 - Has the inner corner (D) that is not worn;
6. Otherwise overturn or replace the skirts according to the following procedure.

Overturning or replacement

7. Remove the wing nuts (E), then remove the retaining strip (F).
8. Remove the skirt blade (G) and, if possible, overturn the blade to replace the lower inner corner (D) with the opposite one. If the other corner is worn too, replace the blade.

Assembly and height adjustment

9. Assemble the blades (G) and skirt assembly (B) in the reverse order of disassembly.
10. Start the machine and lower the cylindrical brush deck, then check that the side skirt blades (G):
 - Slightly touch the floor;
 - Collect the solution.
11. If necessary stop the machine and adjust the skirt height by loosening the knob (A) and turning the knobs (H).
12. After adjusting, tighten the knob (A).

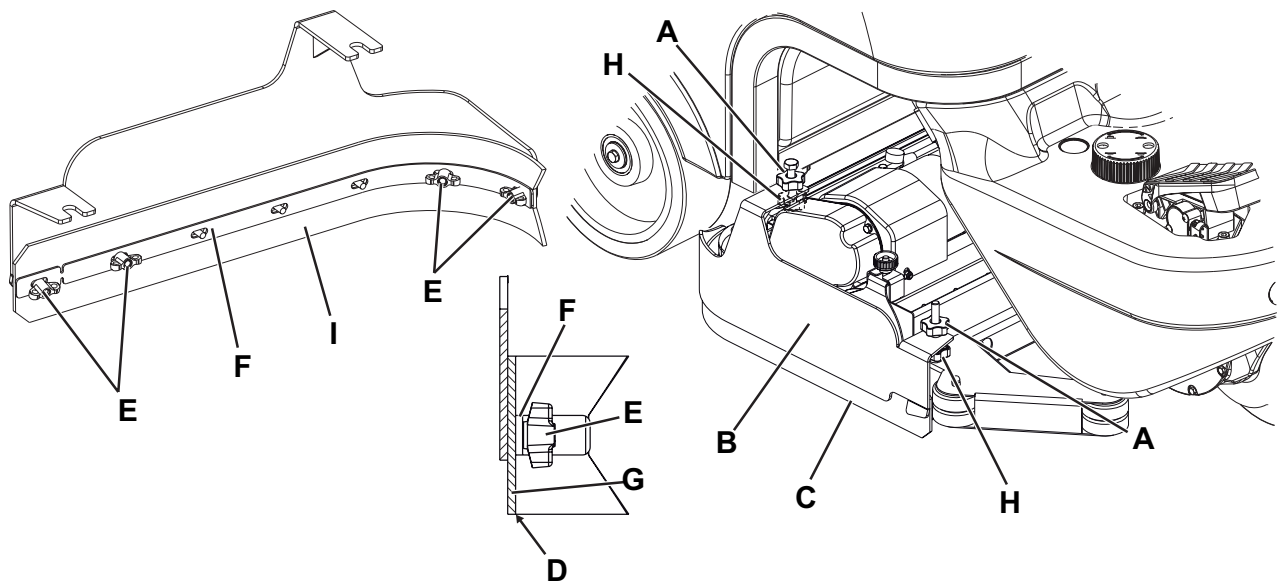

Troubleshooting

Open circuit

- The Brush deck fuse (F1) determines an open in the supply circuit of the brush deck motors. This system allows to prevent the wiring from being damaged under overload conditions.
- The open in the fuse can be caused by the following:
 - Short circuit in the brush motor wiring harness; fault in the motor.

Trouble	Possible Causes	Remedy
All brushes do not turn	The brush motor electromagnetic switch wiring harness is damaged	Repair
	The function electronic board (EB1) is faulty	Replace
	The wiring harness between function electronic board (EB1) and brush motor electromagnetic switch (ES1) is damaged	Repair
	The brush motor electromagnetic switch (ES1) is damaged	Replace
	The brush motor fuse (F1) is open	Replace
One brush does not rotate	The motor carbon brushes are worn	Replace
	Bulky debris or cords around the brushes or between the brushes and its flange	Remove and clean the brushes
	The motor is faulty	Repair or replace
	The wiring harness is damaged	Repair
The brush cannot be lifted/lowered		See the Electrical System chapter, function electronic board error codes
	The deck lifting/lowering actuator (M5) end-of-stroke microswitches are broken	Replace the actuator
	The deck lifting/lowering actuator (M5) is broken	Replace
	Open circuit in the actuator wiring harness	Check the connections according to the instructions in the Electrical System chapter, Troubleshooting paragraph
	The actuator fuse (F4) is open	Replace
	The function electronic board (EB1) is damaged	Replace
The machine does not collect the solution completely	The side skirts are not properly adjusted	Adjust/replace

Removal and Installation

Removing and Installing the Brush Deck

Disassembly

1. Drive the machine on a level floor or on a hoisting system to facilitate the disassembly procedures.
2. Remove the side skirt assemblies, the cylindrical brushes and debris container.
3. Turn the ignition key to "I", lower the cylindrical brush deck by pressing the scrub On/Off push button  and then turn the ignition key to "0".
4. Disconnect the red connector (A).
5. Disconnect the solution hose union (B).
6. Remove the safety pins (C).
7. Unscrew the mounting nut (D) and recover the

washer.

8. Turn the ignition key to "I", lift the deck holder (E) by pressing the scrub On/Off push button  and then turn the ignition key to "0".
9. Turn the steering wheel all the way to the left to remove the cylindrical brush deck.
10. With a second operator who helps to keep the deck holder (E) further lifted, remove the cylindrical brush deck (F).

Assembly

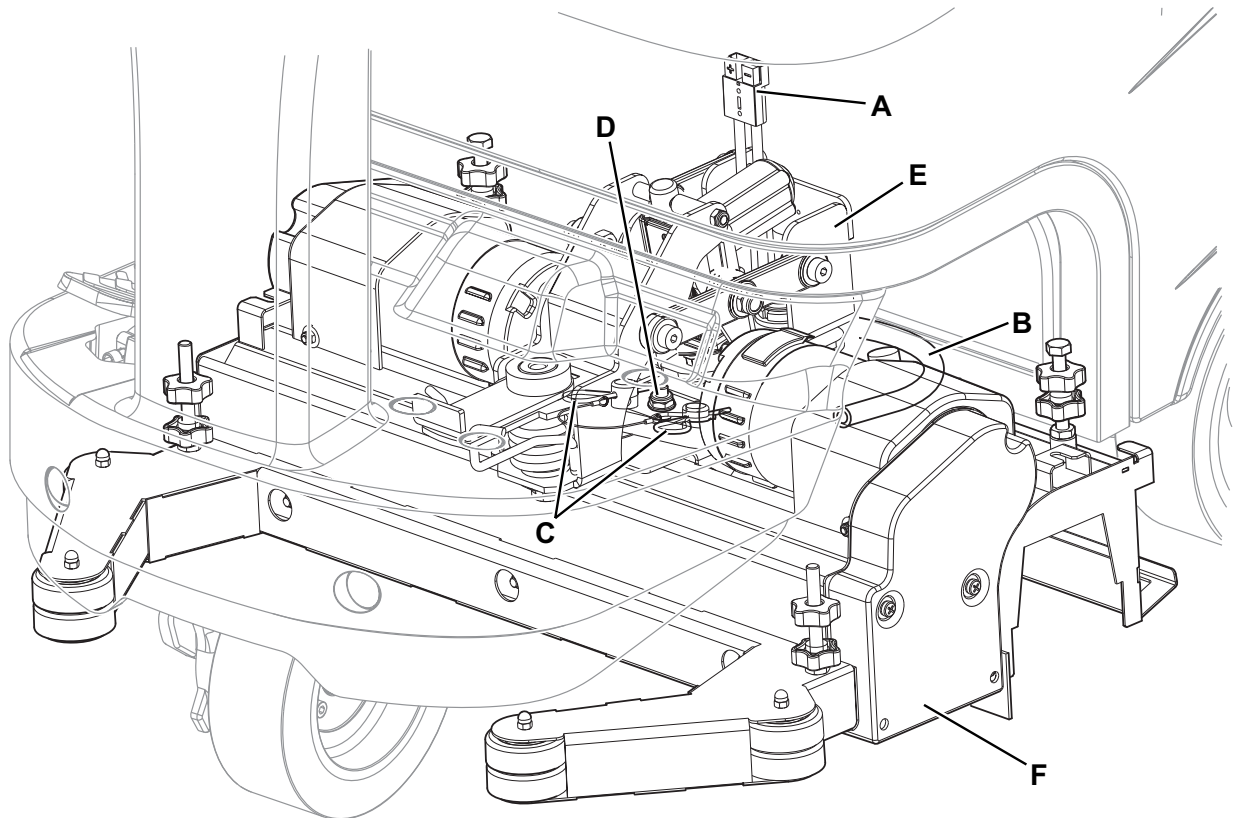

11. Assemble the components in the reverse order of disassembly.



Brush motor electrical input check



Warning! This procedure must be performed by qualified personnel only.

1. Drive the machine on a level floor.
2. Remove the brushes.
3. Place two wooden shims (E) under the side areas of the cylindrical brush deck (C) as shown in the figure. Wooden shim thickness must be 25 mm.
4. Use a jumper wire to disable the driver's seat microswitch.
5. Disconnect the driving wheel connector to disable the drive system.
6. Turn the ignition key to "I" and lower the cylindrical brush deck with the scrub On/Off push button .
7. Install an amp clamp (E) on one cable (F) or (H) of the brush motor.
8. Turn on the brushes by pressing the drive pedal, then check that the electrical input of the right (G) or left motor (I) is 4 to 6 A at 24V.
9. Turn off the brushes by releasing the drive pedal and lift the brush deck by pressing the scrub On/Off push button .
10. Turn the ignition key to "0".
11. Remove the amp clamp (E).

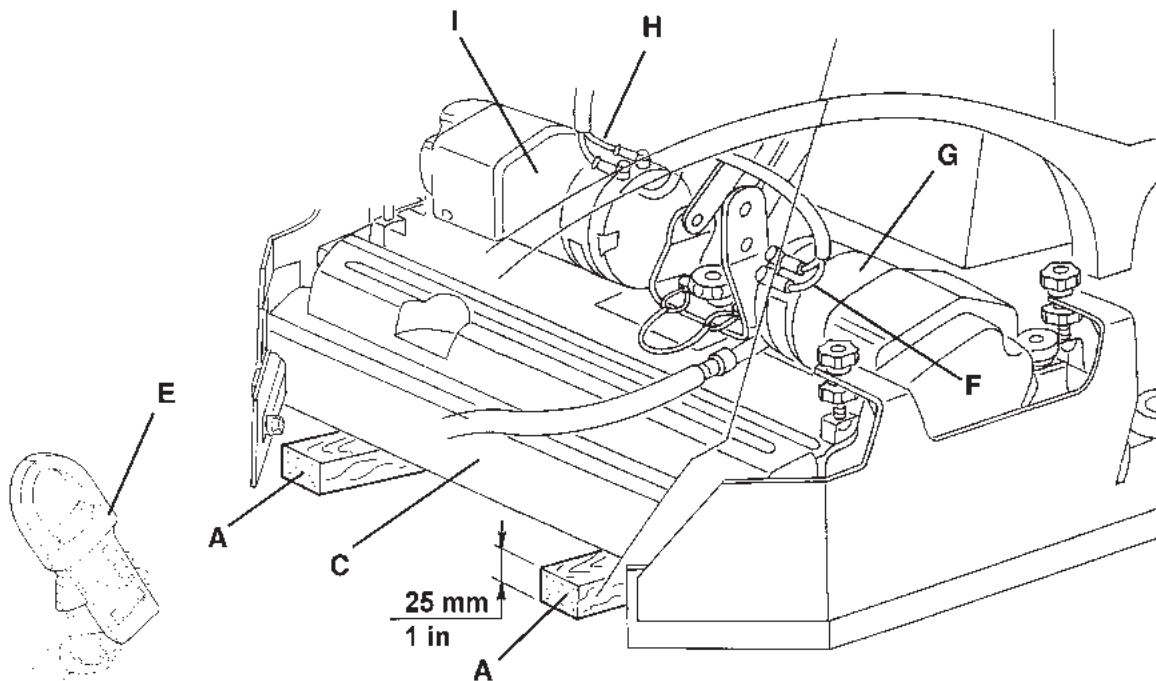

Brush Motor Electrical Input Check (continued)

12. If the electrical input is higher, perform the following procedures to detect and correct the abnormal input:



Note: If the electrical input is higher than the maximum allowed value, the 3 battery warning lights  flash simultaneously.

13. Check the tightening of F1 fuse screws.
14. Check if there is dust or dirt (ropes, cables, etc.) on the brush hubs.
15. Check the motor carbon brushes (see the procedure in the following paragraph).
16. Remove the motors (see the procedure in “Brush motor Disassembly/Assembly” paragraph), and check the condition of all components. If the above-mentioned procedures do not lead to a correct electrical input, it is necessary to replace the motors.

Reset

17. Connect the driving wheel connector.
18. Remove the jumper wire and enable the driver's seat microswitch.
19. Remove the wooden shims and install the brushes.

Brush Motor Carbon Brush Check/Replacement

Check

1. Remove the brush motor.
2. At the workbench, remove dust and debris from the motor, especially in the area of the protection clamp (A).
3. Remove the protection clamp (A).
4. For each carbon brush, move the protection (B) and remove the screws (C).
5. Remove the carbon brushes (D).
6. Check the carbon brushes (D) for wear. Replace the carbon brushes when:
 - The contact with the motor armature is insufficient,
 - The carbon brushes are worn,
 - The carbon brush contact surface is not integral,
 - The carbon brushes when the stroke residual is less than 0.12 in (3 mm),
 - The thrust spring is broken, etc.
7. Replace the carbon brushes as an assembly.

Reset

8. Assemble the components in the reverse order of disassembly.

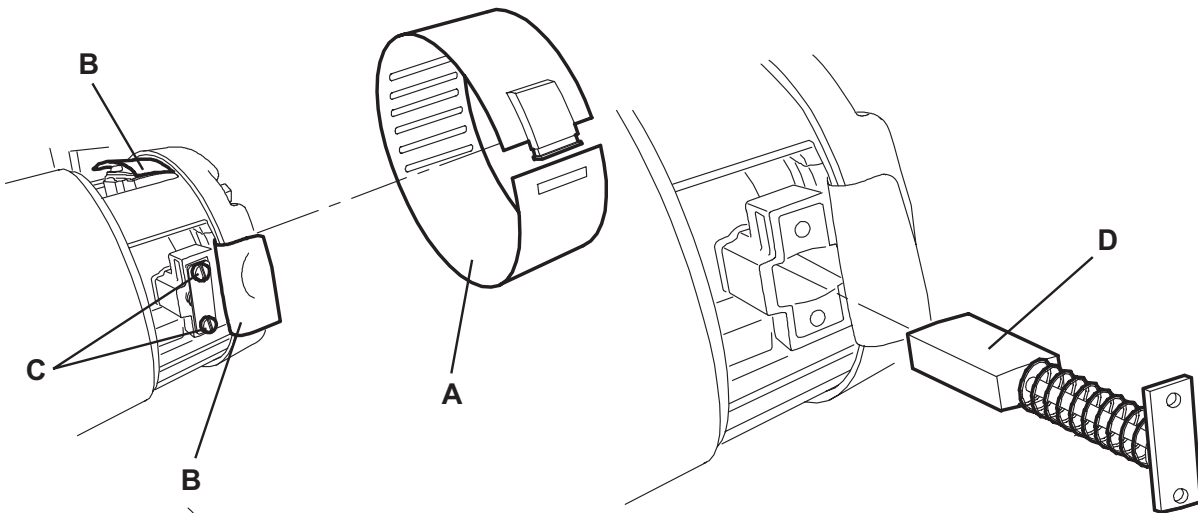

P100722

Brush Motor Disassembly/Assembly

Disassembly

1. Remove the cylindrical brush deck (see the procedure in “Cylindrical Brush Deck Disassembly/Assembly” paragraph).
2. On the machine side where the brush motor has to be removed, unscrew the knobs and remove the side skirt assembly.
3. Remove the screws (A) and remove the case (B).

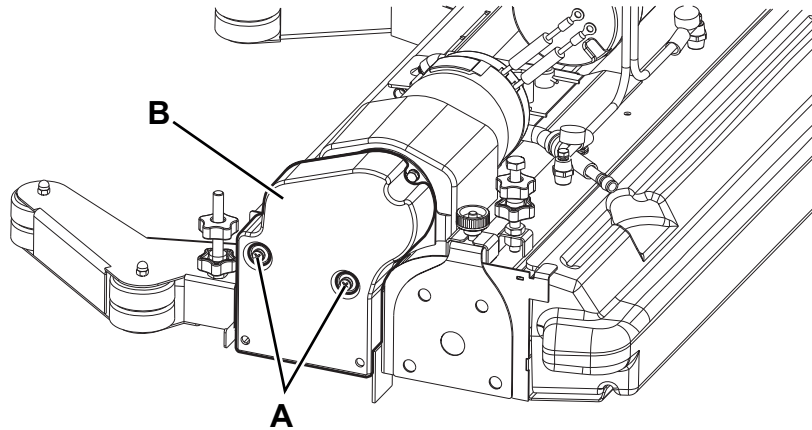

P100723

Brush Motor Disassembly/Assembly (continued)

5. Remove the guard (C).
6. Loosen the nut (D) and move the pulley (E) to loosen the belt (F).
7. Remove the belt (F).
8. Remove the screws (G).
9. Remove the motor (H).

Assembly

10. Assemble the components in the reverse order of disassembly, and note the following:
 - The electrical connections (L) of the motor (H) must be turned to the rear side of the cylindrical brush deck.
 - The connection (J) of the carbon brush protection clamps (I) must be positioned as shown in the figure.
 - Install the belt (F) and tension it properly (see the procedure in the relevant paragraph).



Note: For further information on deck components see the Parts List.

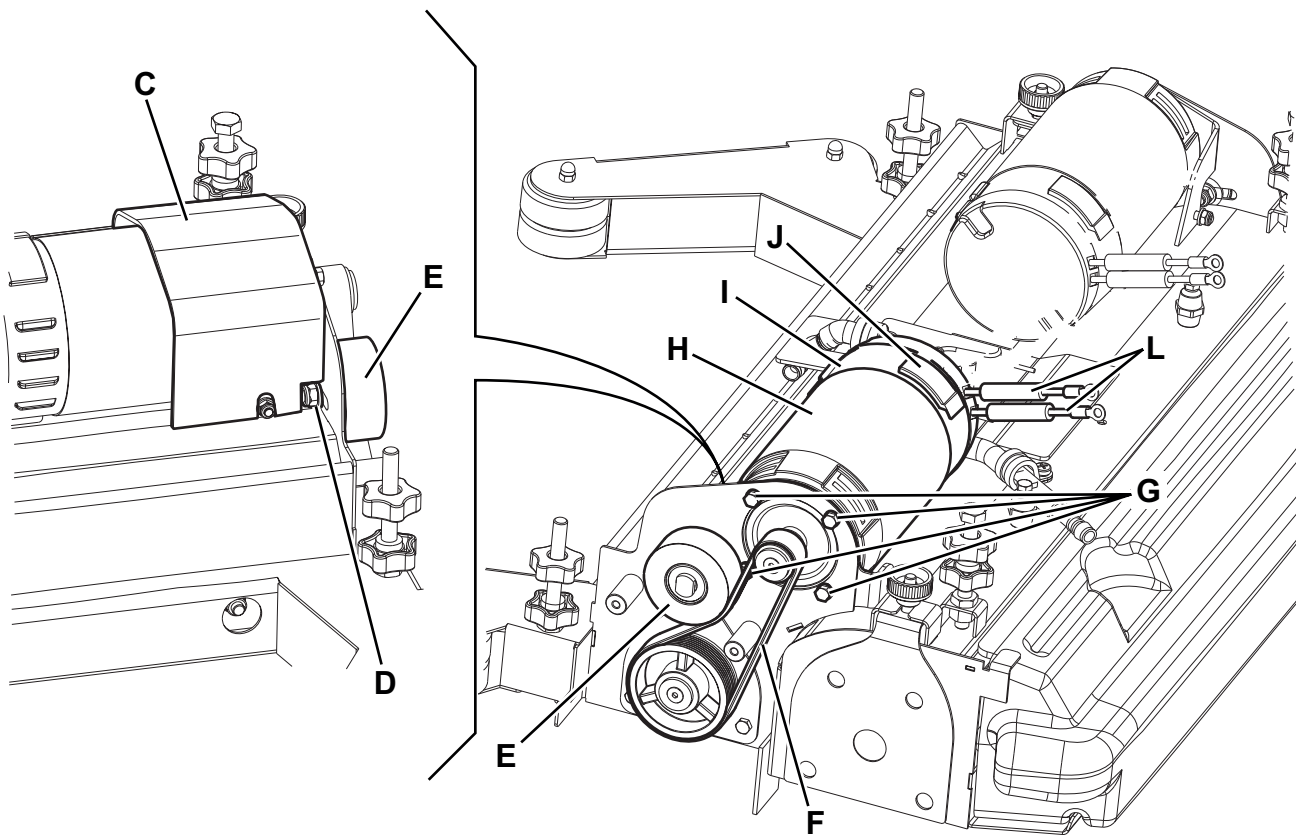

Check/replacement/adjustment of driving belts between motors and cylindrical brushes

Check

1. Drive the machine on a level floor.
2. Lower the brush deck by pressing the scrub On/Off push button .
3. Turn the ignition key to "0" and disconnect the batteries.
4. On both sides of the machine, unscrew the knobs and remove the side skirt assemblies.
5. Remove the screws (A) and remove the covers (B).
6. Visually inspect the driving belt (C) for integrity, cuts, tears or cracks and, if necessary, replace it according to the following procedure.
7. Check the driving belt tension (C) according to the following procedure.

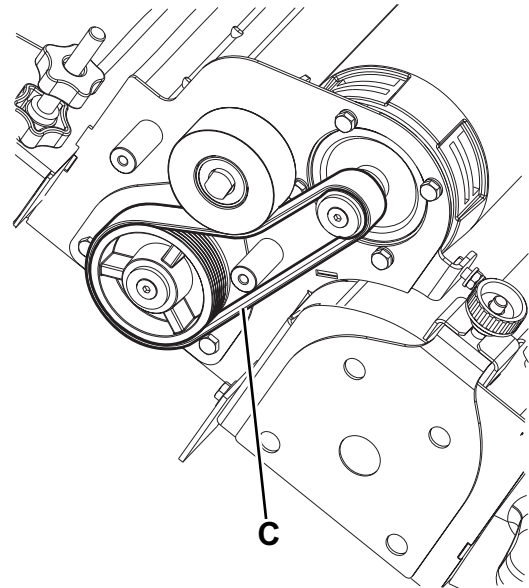
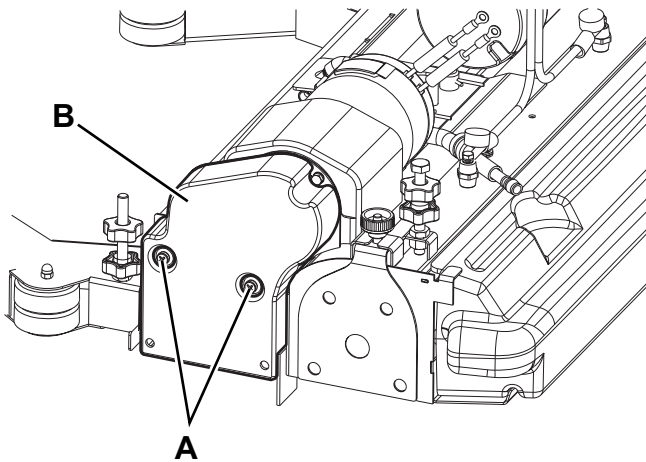

P100725

Check/replacement/adjustment of driving belts between motors and cylindrical brushes (continued)

Replacement

8. If the belt (C) is to be replaced, remove the guard (D), loosen the nut (E) and move the pulley (F) to loosen the belt.
9. Remove or replace the driving belt.
10. Stretch the driving belt (according to the following procedure).

Belt tensioning

11. Check the tension of the driving belt (C) between motor and brush. The tension is correct when the driving belt bends for 5 mm when pressing the driving belt in its centre with a force of 10 kg (G).
12. If necessary, stretch the driving belt according to the following procedure:
13. Remove the cover (D), loosen the nut (E) and adjust the position of the pulley (F) as necessary. When tensioning procedure has been performed, tighten the nut (E).
14. Repeat step 11.

Reset

15. Install the guard (D) and perform steps 3, 4 and 5 in the reverse order.

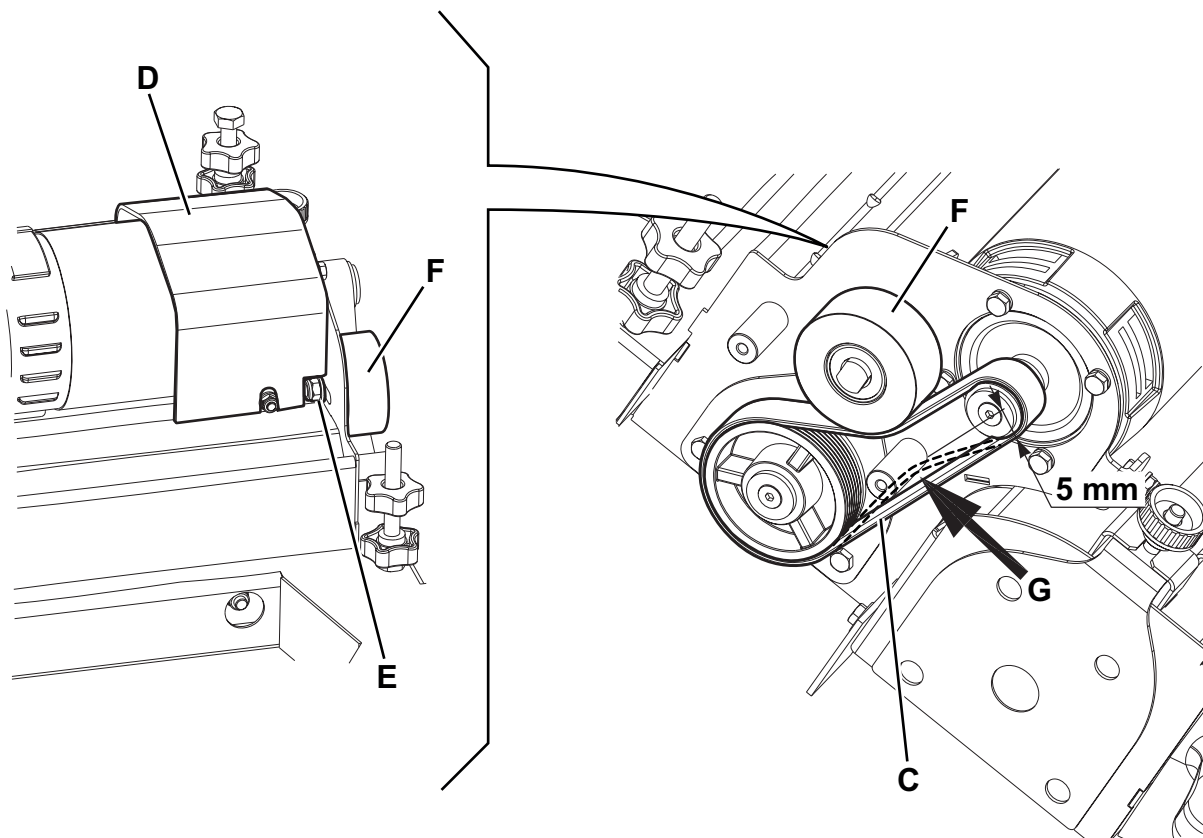

Brush Deck Lifting/Lowering Actuator Disassembly/Assembly

Disassembly

1. Lower the brush deck.
2. Remove the cylindrical brush deck (see the procedure in “Cylindrical Brush Deck Disassembly/Assembly” paragraph).
3. Turn the ignition key to “0” and disconnect the batteries.
4. Disconnect the actuator connector (see the function electronic board).
5. Remove the screw (A) and recover nuts, bushings and washers.
6. Remove the screw (B) and recover the washer.
7. Remove the actuator (C).

Assembly

8. Assemble the components in the reverse order of disassembly.

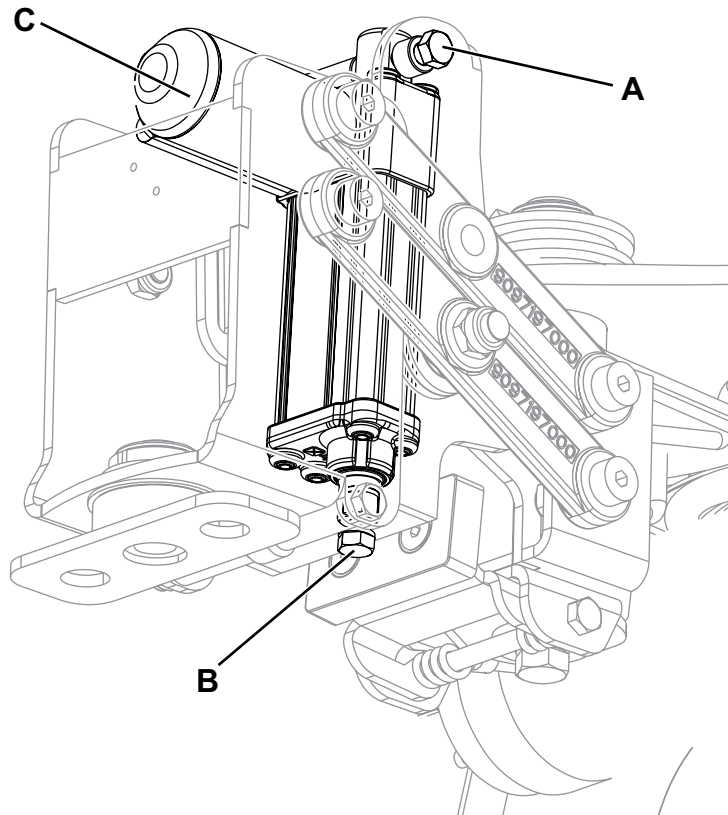

Specifications

Description		SCRUBTEC R 471C
Cleaning width		28 in (710 mm)
Cylindrical brush size (diameter x length)		5.7 x 27.2 in (145 x 690 mm)
Deck right/left offset		3.5 / 3.5 in (90 / 90 mm)
Cylindrical brush deck distance from the floor (when lifted)		0.8 in (22 mm)
Brush electromagnetic switch		24V 70A
Cylindrical brush motor technical data		2 x 0.8 hp (2 x 600 W 24V)
		1800 rpm
Actuator technical data	Maximum load	700 N
	Maximum speed	16 mm/s
	Voltage	24V
	Protection class	IP 65
Cylindrical brush speed		720 rpm
Cylindrical brush pressure		77.1 lb (35 kg)

Scrub System, Disc

Functional Description

The disc brush system can be started by the operator.

The disc brushes turn in opposite directions towards the centre of the header.

The rotating brush system cleans the surface of the floor. The deck, where brushes suitable for cleaning the particular type of floor are installed, is the main part of the brush system.

The brush deck is mounted on a “magic deck” pantograph system with an electrical actuator and gas spring.

The “magic deck” system lets the brush deck traverse sideways and the steering system turn thanks to a rack.

The “magic deck” system also traverses the deck to the side if it collides with an obstacle.

The electrical actuator, with limit microswitches, lifts and lowers the deck. The operating and washing pressure depends on the weight of the deck. The actuator and gas spring provide extra pressure function. The extra pressure function can be selected with the specific button on the dashboard.

The brushes rotate when the brush motors are activated by the function electronic board when the pedal is pressed.

The brush system uses the solution to wash the floor.

In case of brush motor overload, a safety system stops the brushes after about one minute of continuous overload. The overload is shown by the three battery warning leds flashing simultaneously.

The overload is detected monitoring the sum of current flow on the motors. The current is measured by a voltage drop verification across the brush system fuse (F1). If the voltage drop become over the value stored in the “VS2” parameter (default = 70 mV), the 3 battery leds start flashing simultaneously and if the overload persists, after a variable delay depending on the overload amount, the motors will stop.

If the overload takes place when the extra pressure function is on, the system automatically turns the extra pressure function off. If the overload persists, the brushes stop.

To start scrubbing again after a brush/pad-holder stop due to overload, stop the machine by turning the ignition key to “0”. Turn on the machine by turning the ignition key to “I”.

In summary, the brush motor running needs the following conditions/inputs:

- Seat microswitch closed
- Brushes function enabled
- Drive pedal pressed
- Battery level not in red light blinking condition.

Wiring Diagram

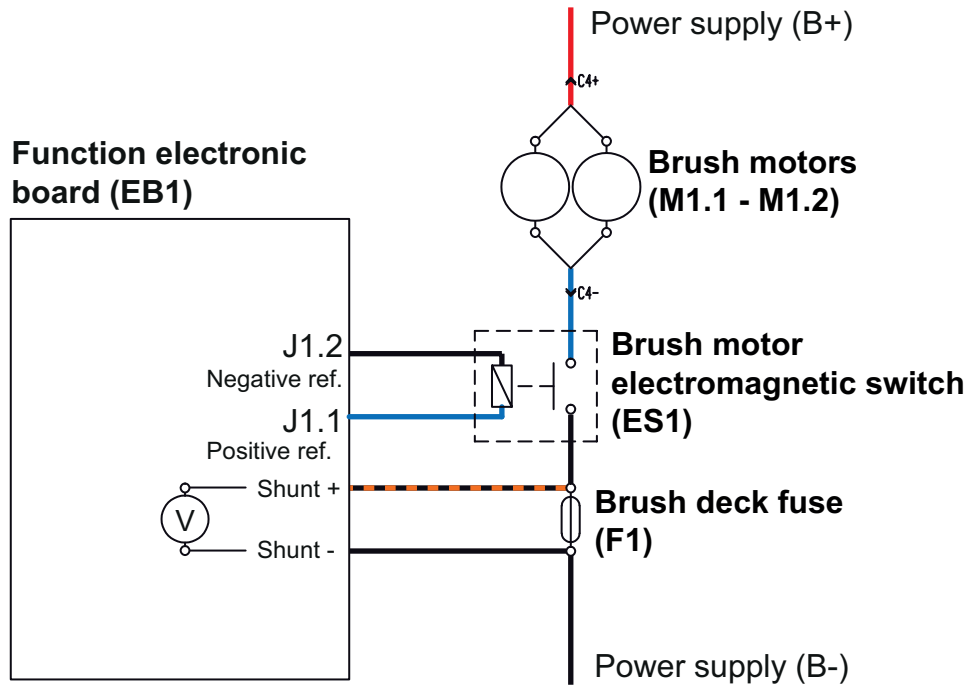

P100712

Actuator Wiring Diagram

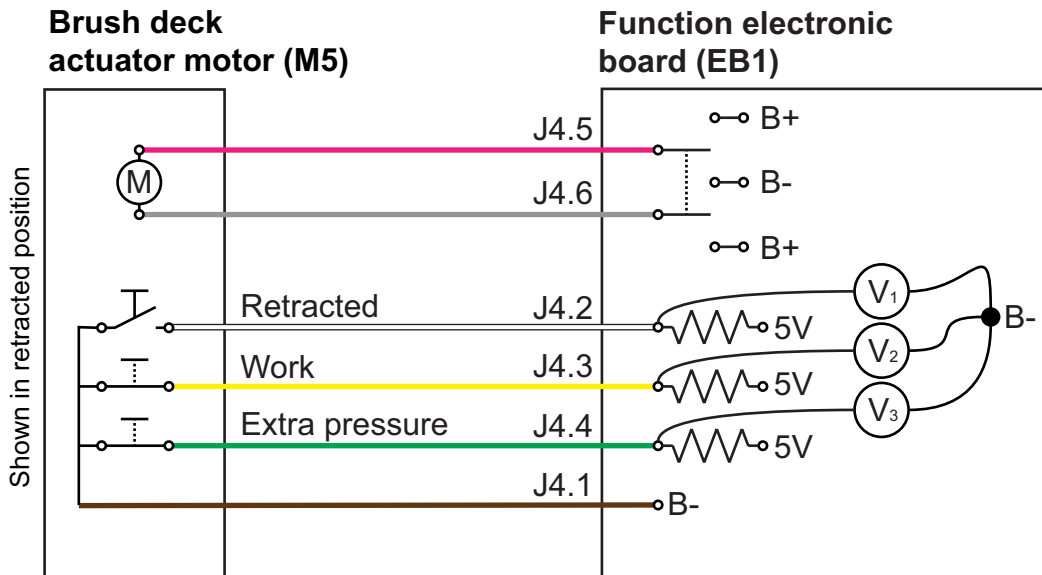

P100713

Voltage reference	Actuator position		
	Retracted	Work	Extrapressure
V ₁	5V	0V	0V
V ₂	0V	5V	0V
V ₃	0V	0V	5V

Component Location

- Disc brush deck
- Brush gearmotor (M1, M2)
- Drive hub
- “Magic deck” system
- Brush deck lifting/lowering actuator (M5)
- Gas spring for extra pressure
- Brush electromagnetic switch (ES1)

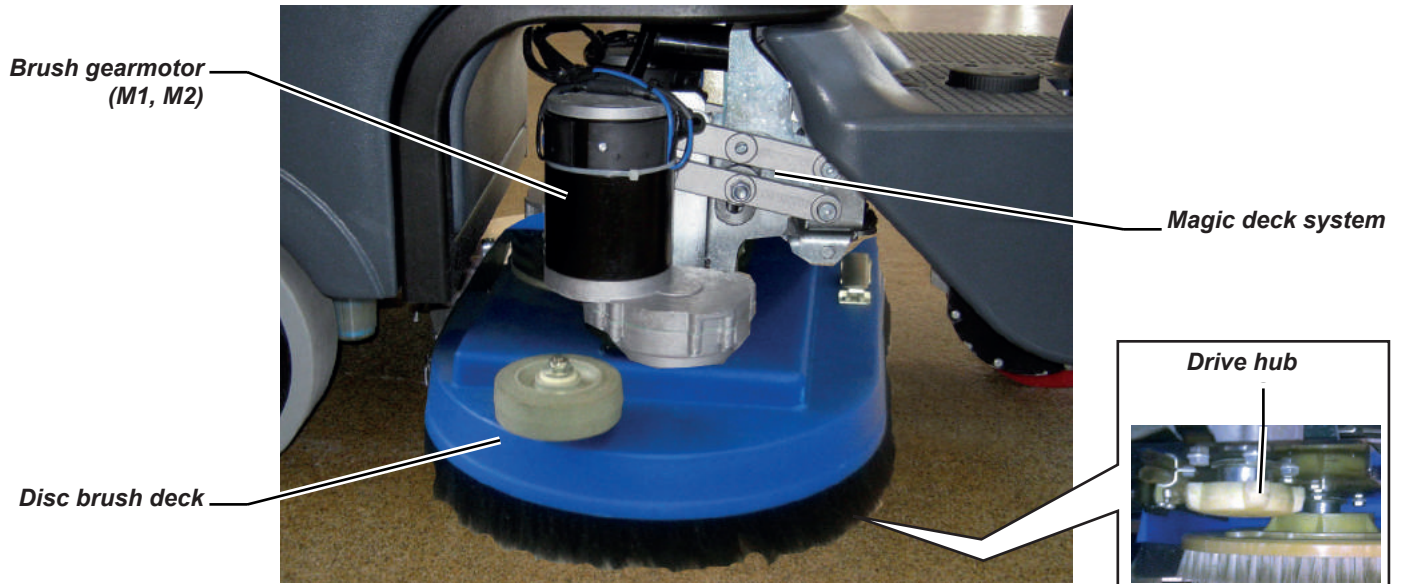

P100728

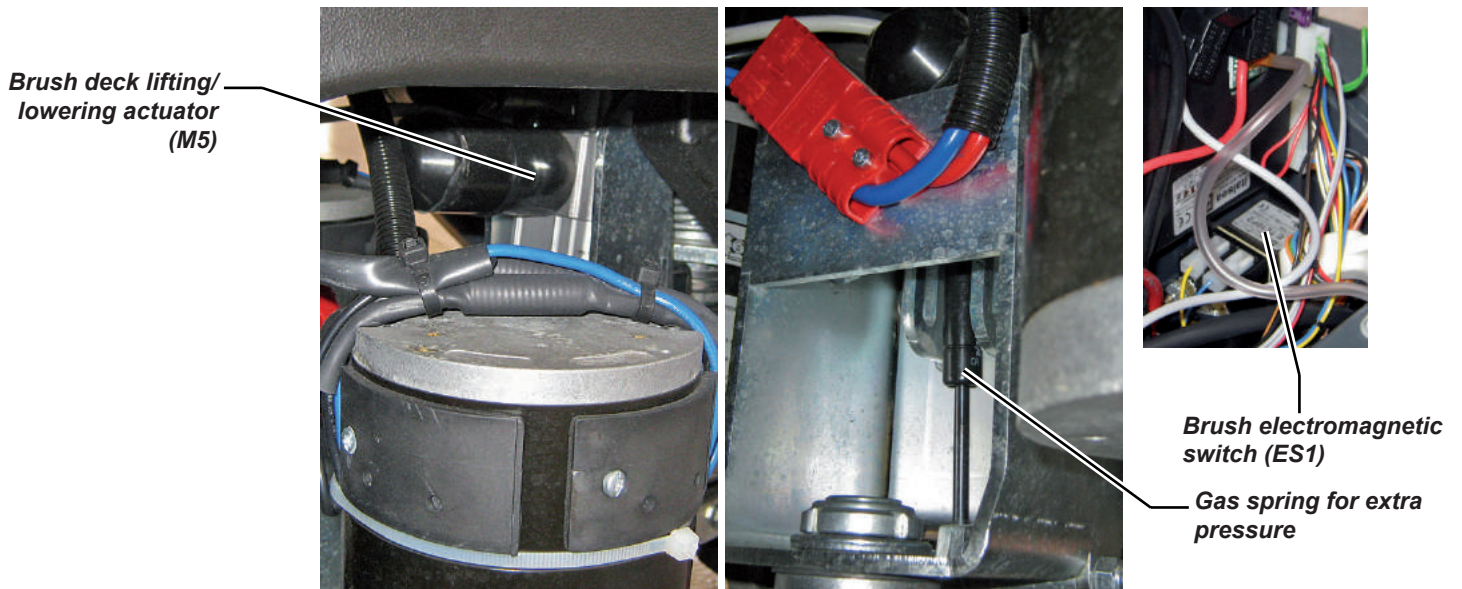

P100729

Component Location (continued)

- Brush deck fuse (F1)
- Actuator system wiring harness connection
- Function electronic board (EB1)

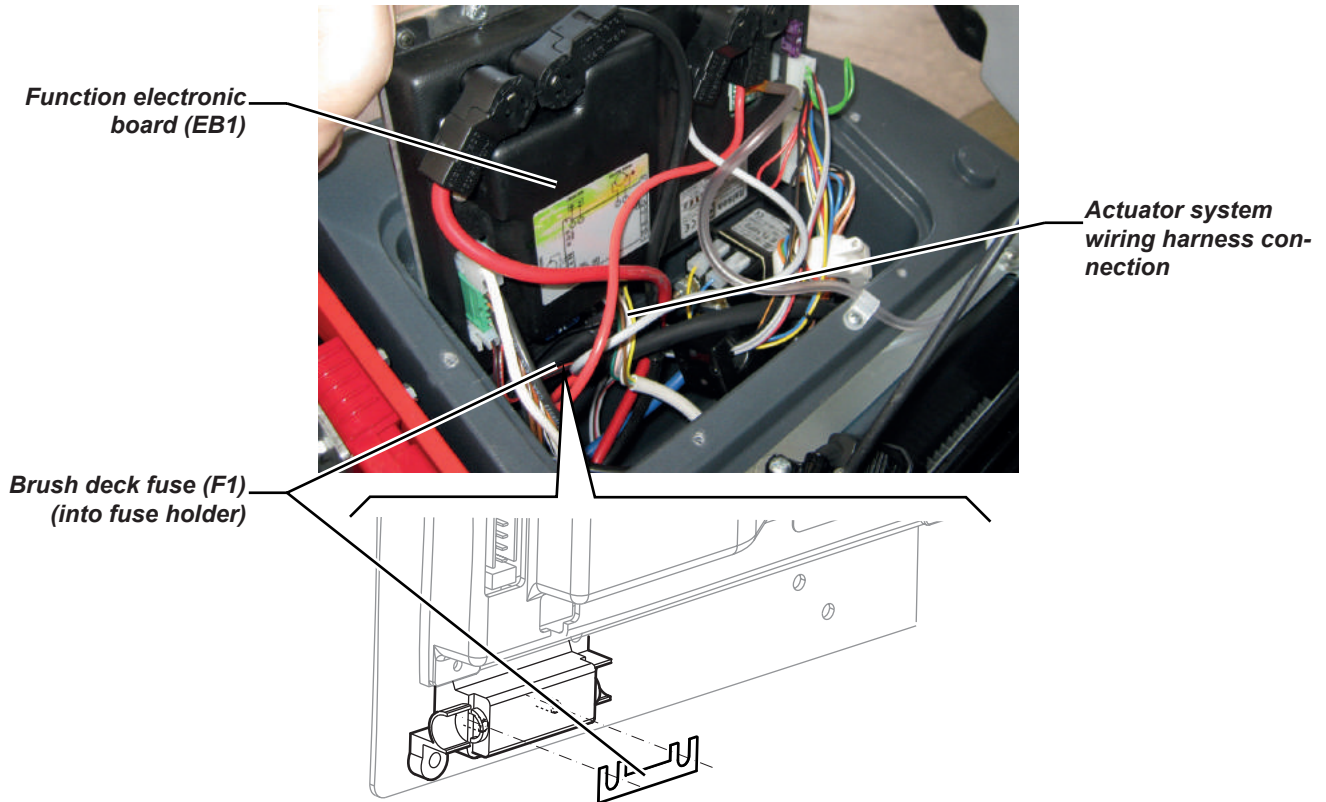



Maintenance and Adjustments

Brush/pad-holder installation/removal

1. Insert the ignition key and turn it to "I".



Warning! Before pressing the scrub On/Off push button , always check that, between the deck and the machine there is no foreign material which may prevent the deck from lifting.

2. Lift the deck by pressing the scrub On/Off push button .
3. Turn the ignition key to "0".
4. Manually move the deck assembly to the left, then release the lever (D) and disassemble the covers (E) and (F) from the deck.
5. Install the brushes/pad-holders on the deck drive hub (G) by pushing them upwards until they are engaged.
6. To remove the brushes/pad-holders perform steps 1 to 3, then release them from the hub by pushing firmly downwards.



Warning! If the machine is not perfectly assembled it can cause damages to people and properties. Always check that all components are assembled before starting the machine. Carefully inspect the machine before using it.

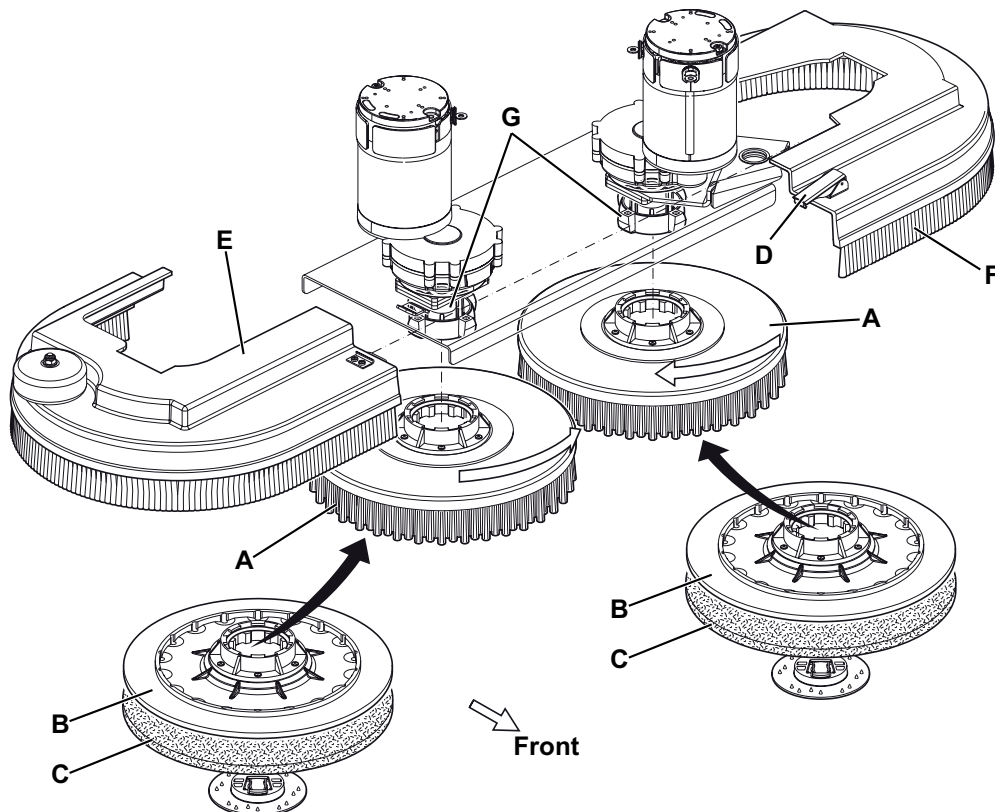

Troubleshooting

Open circuit

- The fuse (F1) determines an open in the supply circuit of the brush deck motors. This system allows to prevent the circuits from being damaged under overload conditions.
- The open in the fuse can be caused by the following:
 - Short circuit in the brush motor wiring harness; fault in the motor.

Trouble	Possible Causes	Remedy
All brushes do not turn	The brush motor electromagnetic switch wiring harness is damaged	Repair
	The function electronic board (EB1) is faulty	Replace
	The wiring harness between function electronic board (EB1) and brush motor electromagnetic switch (ES1) is damaged	Repair
	The brush motor electromagnetic switch (ES1) is damaged	Replace
	The brush motor fuse (F1) is open	Replace
One brush does not rotate	The motor carbon brushes are worn (replace).	Replace
	Bulky debris or cords around the brushes or between the brushes and its flange	Remove and clean the brushes
	The motor is faulty	Repair or replace
	The wiring harness is damaged	Repair
The brush cannot be lifted/lowered		See the Electrical System chapter, function electronic board error codes
	The deck lifting/lowering actuator (M5) end-of-stroke microswitches are broken	Replace the actuator
	The deck lifting/lowering actuator (M5) is broken	Replace
	Open circuit in the actuator wiring harness	Check the connections according to the instructions in the Electrical System chapter, Troubleshooting paragraph
	The actuator fuse (F4) is open	Replace
	The function electronic board (EB1) is damaged	Replace

Removal and Installation

Removing and Installing the Brush Deck

Disassembly

1. Drive the machine on a level floor or on a hoisting system to facilitate the disassembly procedures.
2. Remove the brushes/pad-holder.
3. Turn the ignition key to "I".
4. Lower the brush/pad-holder deck by pressing the scrub On/Off push button .
5. Turn the ignition key to "0".
6. Disconnect the red connector (A).

7. Disconnect the solution hose union (B).
8. Remove the screw (C) and recover the nut.
9. Remove the safety pins (D).
10. Remove the mounting nut (E) and recover the washer, then remove the brush/pad-holder deck (F).

Assembly

11. Assemble the components in the reverse order of disassembly.

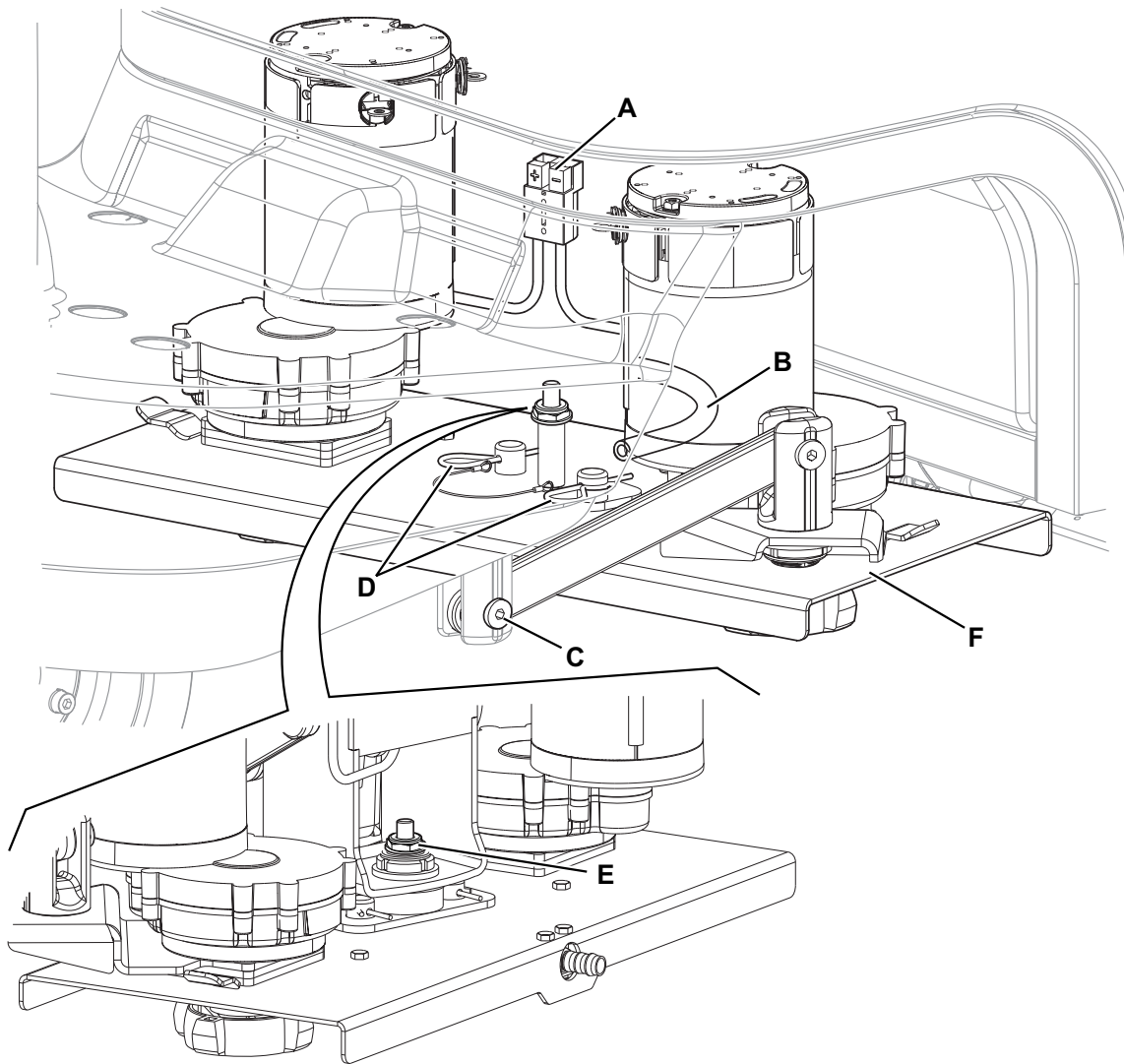

Brush motor electrical input check





Warning! This procedure must be performed by qualified personnel only.

1. Drive the machine on a level floor.
2. Remove the brushes.
3. Place two wooden shims (A) under the side areas of the deck (B) as shown in the figure. Wooden shim thickness must be 25 mm.



Warning! Keep the wooden shims at an appropriate distance from the brush hubs.

4. Use a jumper wire to disable the driver's seat microswitch.
5. Disconnect the driving wheel connector to disable the drive system.
6. Turn the ignition key to "I" and lower the brush/pad-holder deck with the scrub On/Off push button .
7. Install an amp clamp (E) on one cable (F) or (H) of the brush motor.
8. Turn on the brushes by pressing the drive pedal, then check that the electrical input of the right (G) or left motor (I) is 3 to 4 A at 24V.
9. Turn off the brushes by releasing the drive pedal and lift the brush/pad-holder deck by pressing the scrub On/Off push button .
10. Turn the ignition key to "0".
11. Remove the amp clamp (E).

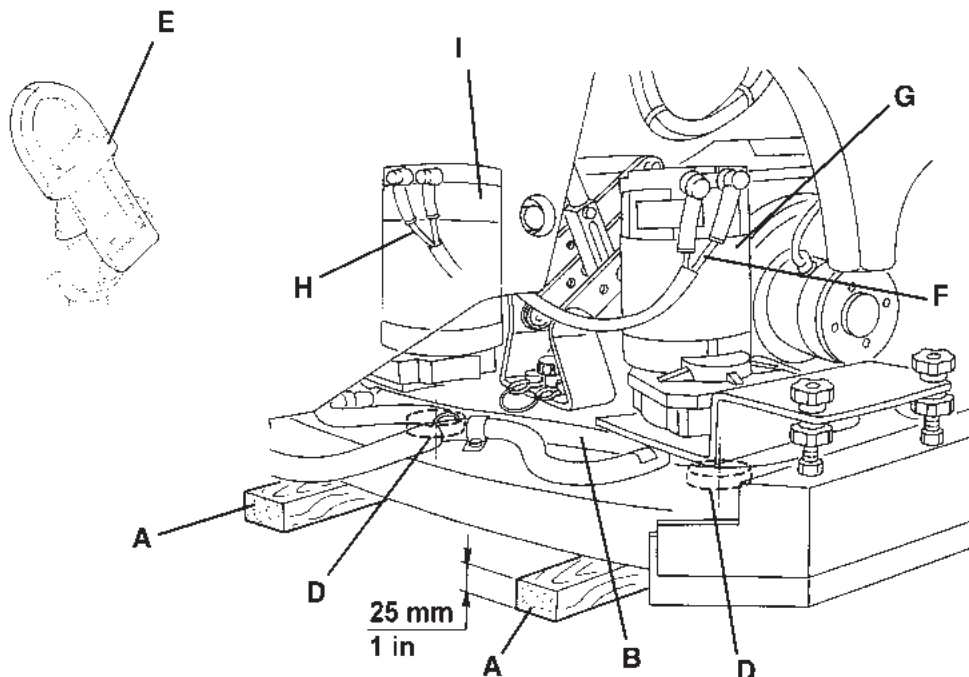

Brush Motor Electrical Input Check (continued)

12. If the electrical input is higher, perform the following procedures to detect and correct the abnormal input:



Note: If the electrical input is higher than the maximum allowed value, the 3 battery warning lights  flash simultaneously.

13. Check the tightening of F1 fuse screws.
14. Check if there is dust or dirt (ropes, cables, etc.) on the brush hubs.
15. Check the motor carbon brushes (see the procedure in the following paragraph).

Remove the motors (see the procedure in “Brush motor Disassembly/Assembly” paragraph), and check the condition of all components. If the above-mentioned procedures do not lead to a correct electrical input, it is necessary to replace the motors.

Reset

16. Connect the driving wheel connector.
17. Remove the jumper wire and enable the driver's seat microswitch.
18. Remove the wooden shims and install the brushes.

Brush Motor Carbon Brush Check/Replacement

Check

1. Remove the brush/pad-holder deck.
2. Remove dust and dirt from the motor carbon brush support area (A).
3. Disengage the fasteners (B) and (C), then remove the four carbon brush supports (A). If necessary, disconnect the electrical connections (D).
4. Check the carbon brushes (E) for wear. Replace the carbon brushes when:
 - The contact with the motor armature is insufficient,
 - The carbon brushes are worn,
 - The carbon brush contact surface is not integral,
 - The carbon brushes when the stroke residual is less than 0.12 in (3 mm),
 - The thrust spring is broken, etc.
5. If necessary, disconnect the connections (F) and remove the carbon brushes with their supports (A) and replace them.
6. Replace the carbon brushes as an assembly.

Reset

7. Assemble the components in the reverse order of disassembly, and note the following:
 - When connecting the terminals (F), take care of their insulation from the surrounding parts of the frame.

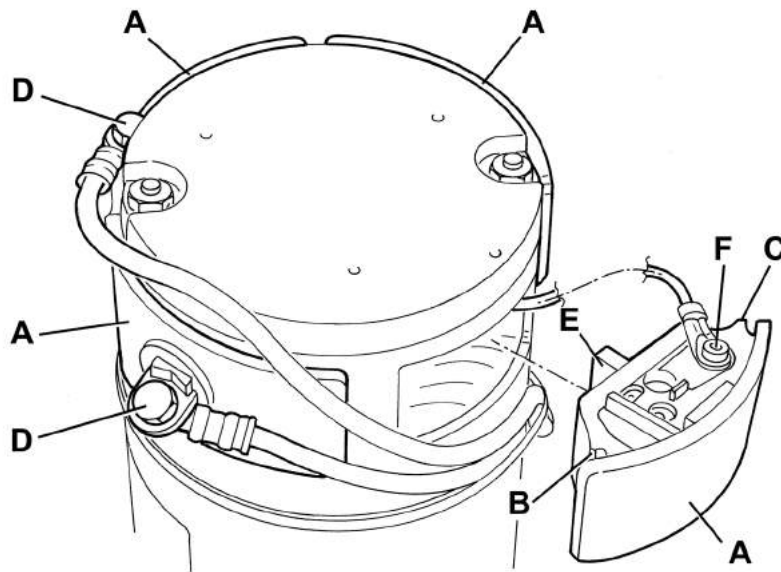

Brush Motor Disassembly/Assembly

Disassembly

1. Remove the brush/pad-holder deck.
2. At the workbench, remove the screw (A) from the reduction unit which has to be disassembled.
3. Remove the hub assembly (B) with a puller.
4. Remove the screws (C).
5. Remove the gearmotor (D).
6. Recover the key (E).

Assembly

7. Assemble the components in the reverse order of disassembly.



Note: For further information on deck components see the Parts List.

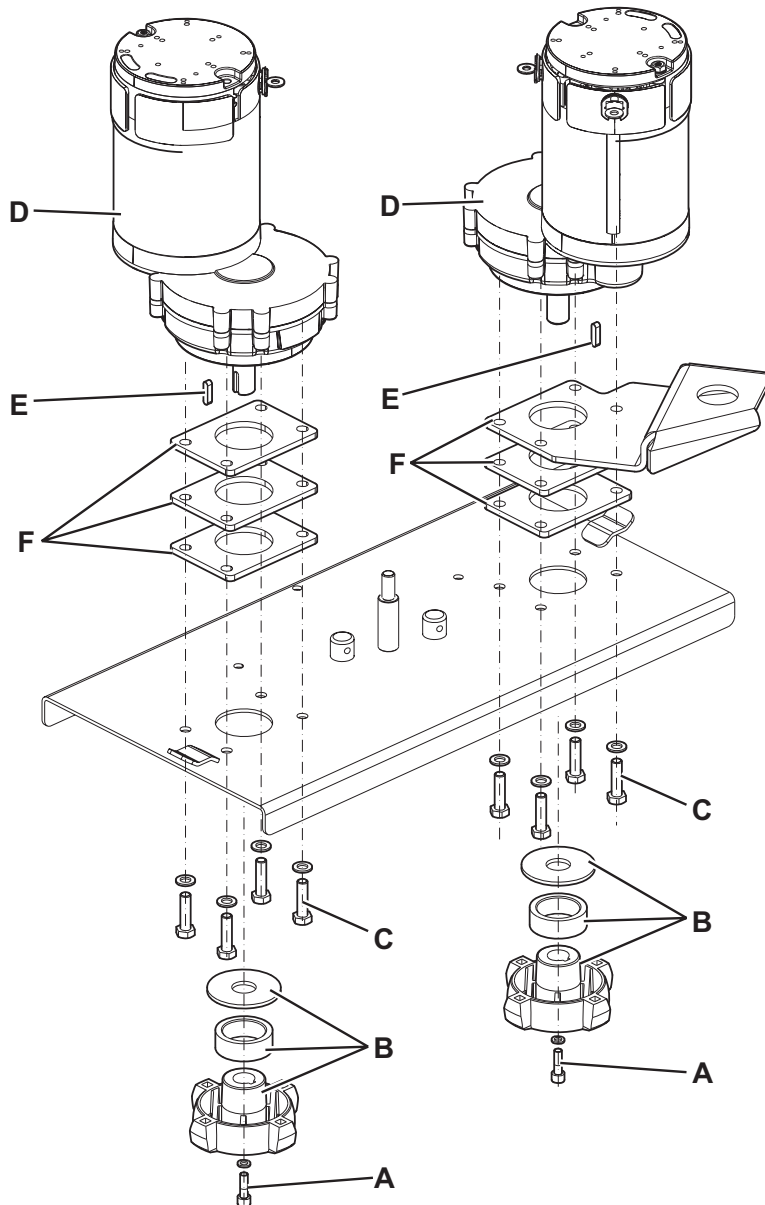

Brush Deck Lifting/Lowering Actuator Disassembly/Assembly

Disassembly

1. Lower the brush deck.
2. Remove the deck.
3. Turn the ignition key to “0” and disconnect the batteries.
4. Disconnect the actuator connector (see the function electronic board).
5. Remove the screw (A) and recover nuts, bushings and washers.
6. Remove the screw (B) and recover the washer.
7. Remove the actuator (C).

Assembly

8. Assemble the components in the reverse order of disassembly.

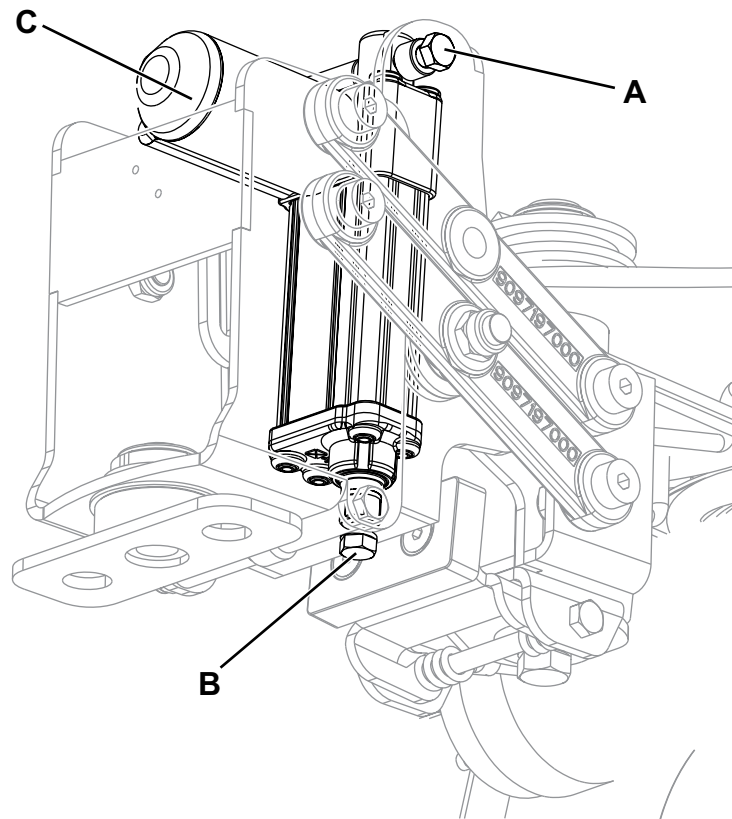

Brush Deck Adjuster Spring Disassembly/Assembly

Disassembly

1. Drive the machine on a level floor.
2. Remove the brush deck.
3. Turn the ignition key to “0” and disconnect the batteries.
4. Remove the front fairing (see the procedure in “Front Fairing Disassembly/Assembly” paragraph, Steering System section).
5. Place a wooden shim (A) under the deck holder assembly. Wooden shim thickness must be 160 mm.
6. Unscrew the ring nut (B), recover the washer, then carefully remove the spring (C).
7. If necessary, replace the spring taking care to properly place the elastic ends (D) on the frame.

Assembly

8. Assemble the components in the reverse order of disassembly, and note the following:
 - Tighten the ring nut (B) so that the deck holder assembly can turn freely.

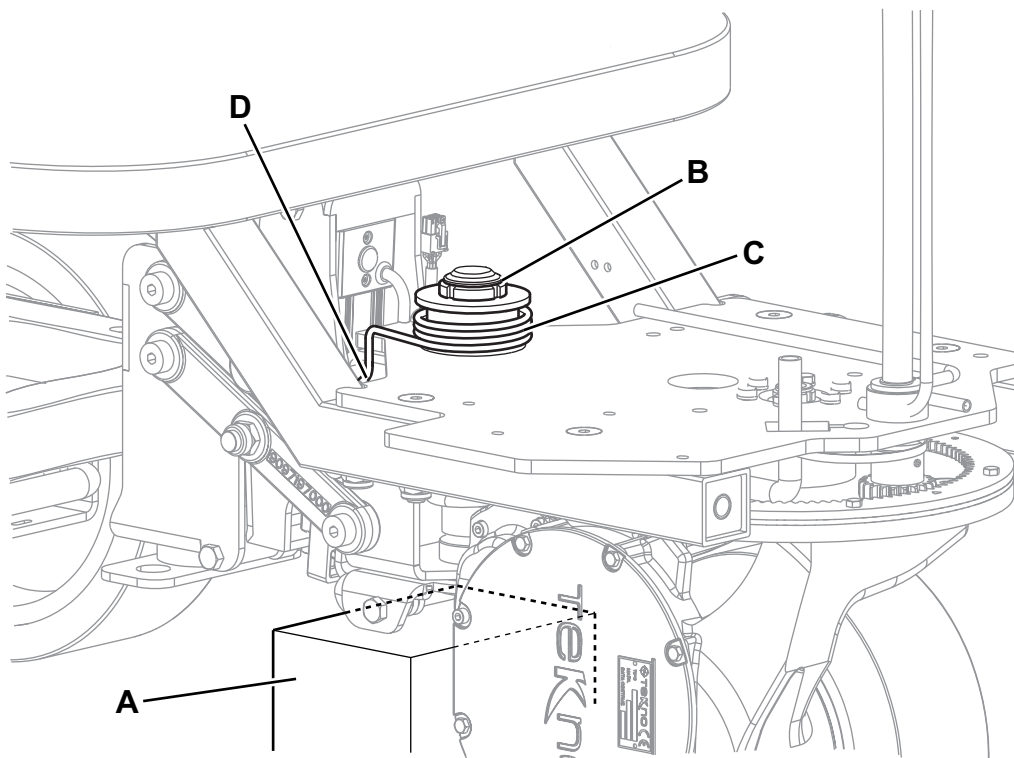

Brush Deck Drive Guide Disassembly/Assembly

Disassembly

1. Drive the machine on a level floor.
2. Remove the brush/pad-holder deck and leave the deck holder assembly lifted.
3. Turn the ignition key to “0” and disconnect the batteries.
4. Turn the steering wheel to accommodate the position of the drive guide (A) to be removed.
5. Under the machine, remove the screws (B) and the drive guide (A).
6. Replace the drive guide if it is too worn.

Assembly

7. Assemble the components in the reverse order of disassembly.

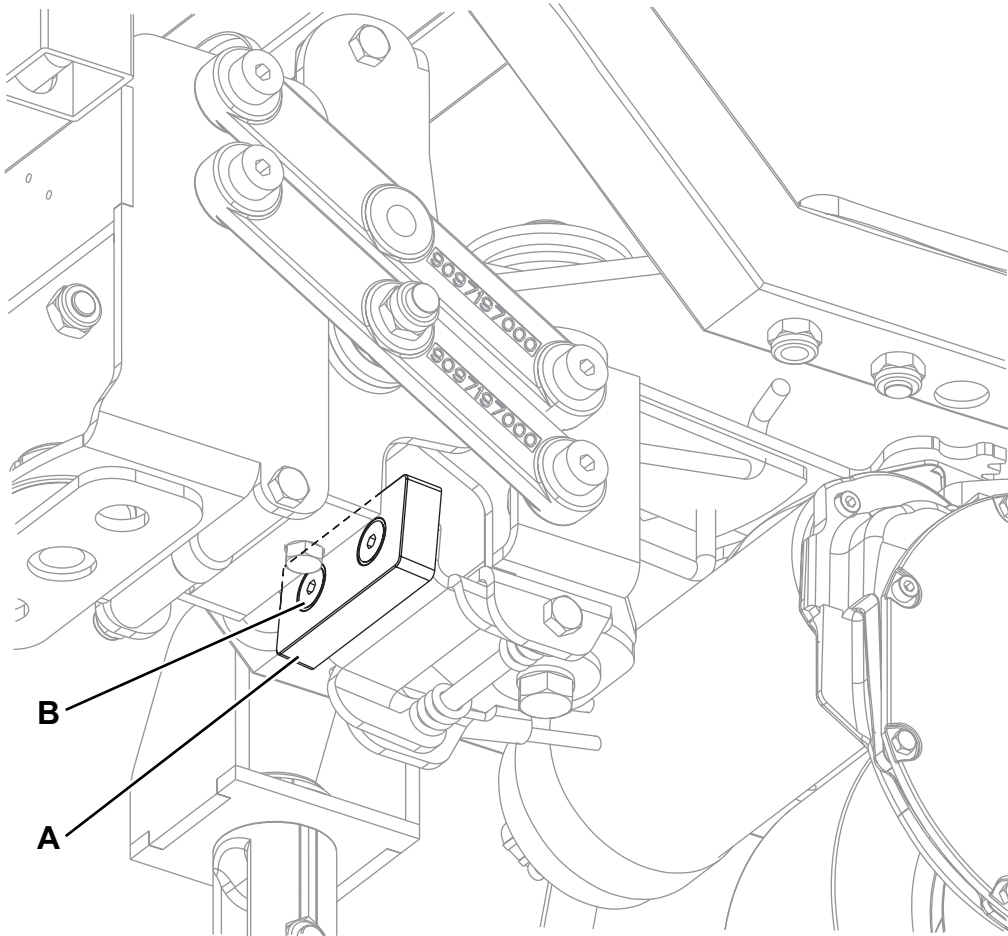

Specifications

Description		SCRUBTEC R 466 - FOCUS II Micro Rider 26D	SCRUBTEC R 471
Cleaning width		26 in (660 mm)	28 in (710 mm)
Brush/pad diameter		13 in (330 mm)	14 in (355 mm)
Deck right/left offset (variable)		0 ÷ 3.9 in / 1 ÷ 0 in (0 ÷ 100 mm / 25 ÷ 0 mm)	0.6 ÷ 5.9 in / 4.1 ÷ 0 in (15 ÷ 150 mm / 105 ÷ 0 mm)
Brush distance from the floor (when lifted)		1.9 in (48 mm)	1.9 in (48 mm)
Brush/pad-holder motor power		2 x 0.53 hp (2 x 400 W)	
Actuator technical data	Maximum load	700 N	
	Maximum speed	16 mm/s	
	Voltage	24V	
	Protection class	IP 65	
Gas spring technical data	Stroke	50 mm	
	Strength	180 N	
Brush/pad-holder speed		230 rpm	
Brush/pad-holder pressure with extra-pressure function turned off		66.1 lb (30 kg)	70.5 lb (32 kg)
Brush/pad-holder pressure with extra-pressure function turned on		105.8 lb (48 kg)	110.2 lb (50 kg)

Scrub System, BOOST®

Functional Description

The BOOST® system can be started by the operator.

The main part of the system is the vibrating deck, the motor with an eccentric transmits the vibration needed to cause the scrub of the pad on the floor to be cleaned.

A series of vibrator isolator deck dampen vibration on the machine.

The BOOST® deck is mounted on a “magic deck” pantograph system with an electrical actuator and gas spring.

The “magic deck” system lets the brush deck traverse sideways and the steering system turn thanks to a rack.

The “magic deck” system also traverses the deck to the side if it collides with an obstacle.

The electric actuator, with limit microswitches, lifts and lowers the deck. The working pressure and washing is provided by the weight of the headboard. The operating and washing pressure depends on the weight of the deck. The actuator and gas spring provide extra pressure function. The extra pressure function can be selected with the specific button on the dashboard.

The system BOOST® started when the brush motor are activated by the function electronic board when the pedal is pressed.

The BOOST® system uses the solution to wash the floor.

In case of brush motor overload, a safety system stops the brushes after about one minute of continuous overload. The overload is shown by the three battery warning leds flashing simultaneously.

The overload is detected monitoring the sum of current flow on the motors. The current is measured by a voltage drop verification across the brush system fuse (F1). If the voltage drop become over the value stored in the “VS2” parameter (default = 70 mV), the 3 battery leds start flashing simultaneously and if the overload persist, after a variable delay depending on the overload amount, the motors will stop.

If the overload takes place when the extra pressure function is on, the system automatically turns the extra pressure function off. If the overload persists, the brushes stop.

To start scrubbing again after a brush/pad-holder stop due to overload, stop the machine by turning the ignition key to “0”. Turn on the machine by turning the ignition key to “I”.

In summary, the brush motor running needs the following conditions/inputs:

- Seat microswitch closed
- Brush function enabled
- Drive pedal pressed
- Battery level not in red light blinking condition.

Wiring Diagram

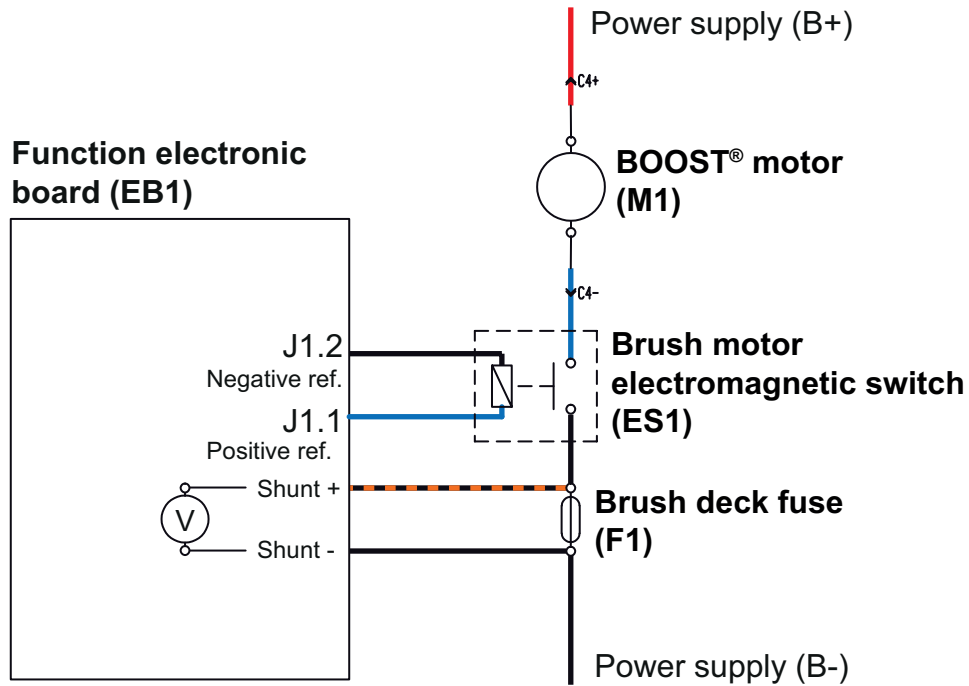

P100736

Actuator Wiring Diagram

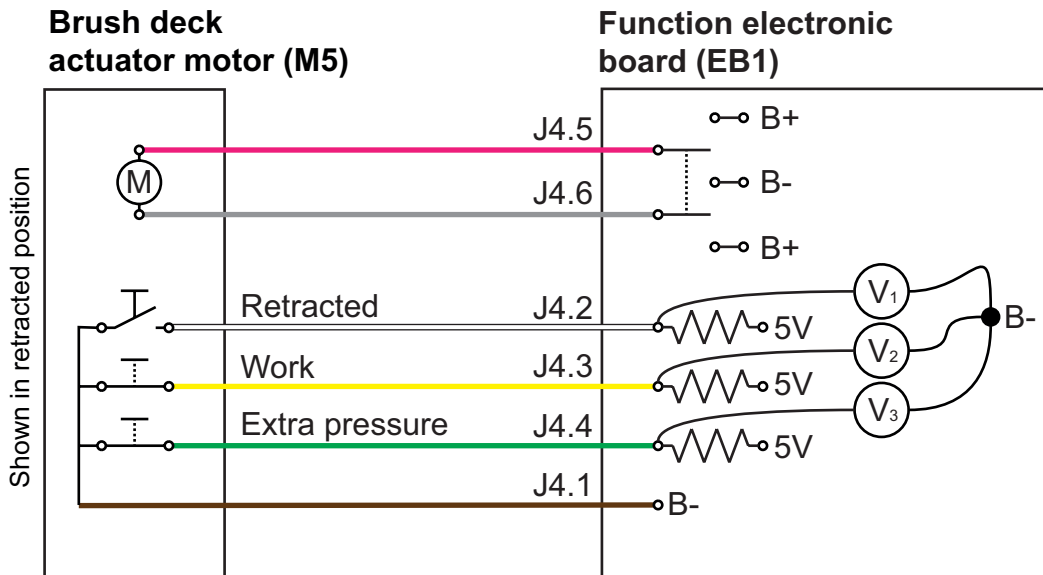

P100713

Voltage reference	Actuator position		
	Retracted	Work	Extrapressure
V ₁	5V	0V	0V
V ₂	0V	5V	0V
V ₃	0V	0V	5V

Component Location

- BOOST® deck
- Flex plate
- Pad
- BOOST® motor (M1)
- Brush deck lifting/lowering actuator (M5)
- Gas spring for extra pressure
- Brush electromagnetic switch (ES1)

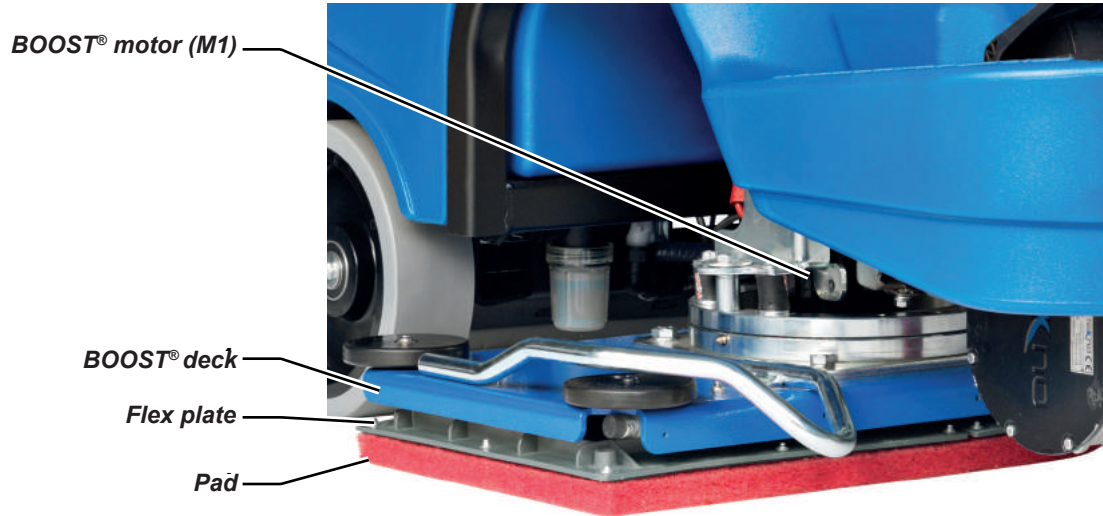

P100737



P100729

Component Location (continued)

- BOOST® deck fuse (F1)
- Actuator system wiring harness connection
- Function electronic board (EB1)

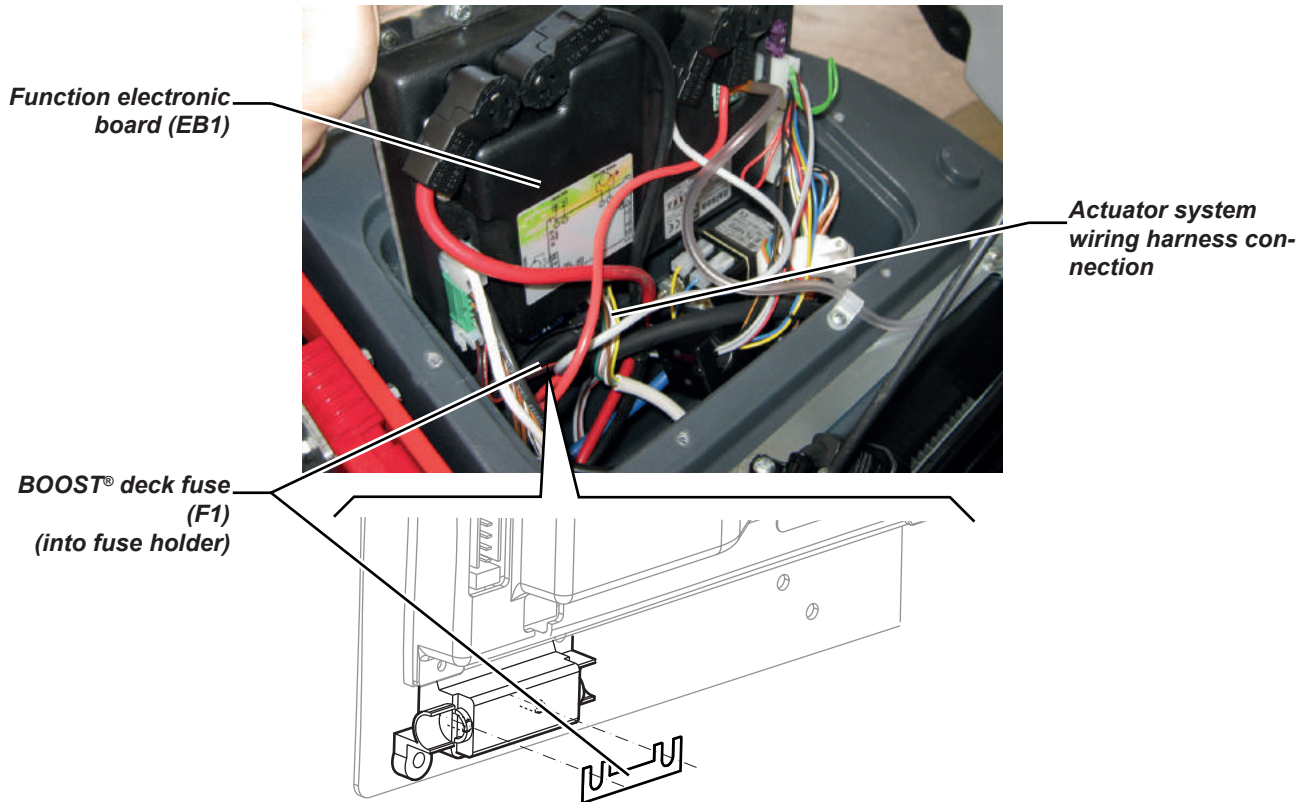



Maintenance and Adjustments

Brush/pad-holder installation/removal

1. Insert the ignition key and turn it to “I”.



Warning! Before pressing the scrub On/Off push button , always check that, between the deck and the machine there is no foreign material which may prevent the deck from lifting.

2. Lift the deck by pressing the scrub On/Off push button .
3. Turn the ignition key to “0”.
4. Install the pad (A) so that it engages the plates on the BOOST® deck.
5. To remove the pad perform steps 1 to 3, then manually release the pad from the deck plate



Warning! If the machine is not perfectly assembled it can cause damages to people and properties. Always check that all components are assembled before starting the machine. Carefully inspect the machine before using it.

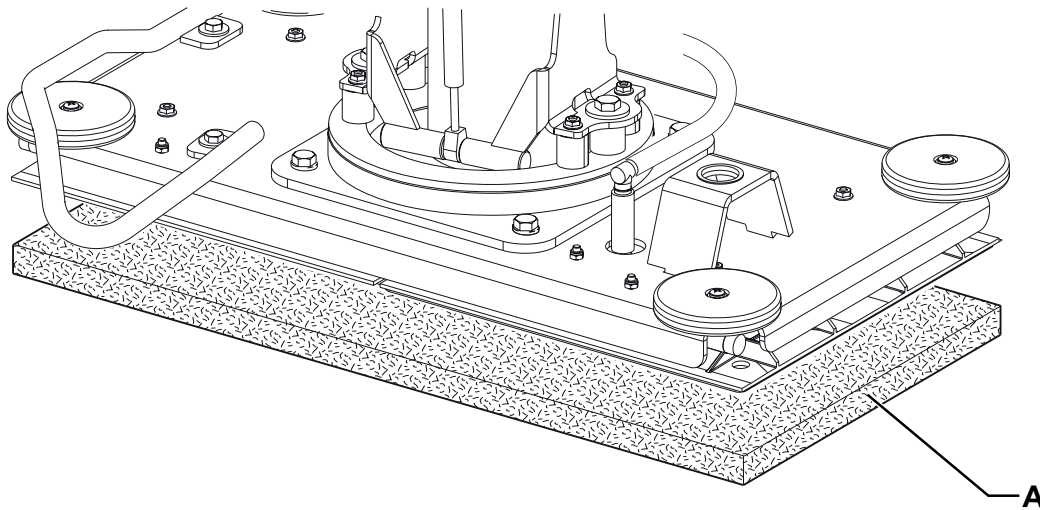

Troubleshooting

Open circuit

- The fuse (F1) determines an open in the supply circuit of the BOOST® deck motors. This system allows to prevent the circuits from being damaged under overload conditions.
- The open in the fuse can be caused by the following:
 - Short circuit in the brush motor wiring harness; fault in the motor.

Trouble	Possible Causes	Remedy
The deck motor do not turn	The deck motor electromagnetic switch wiring harness is damaged	Repair
	The function electronic board (EB1) is faulty	Replace
	The wiring harness between function electronic board (EB1) and deck motor electromagnetic switch (ES1) is damaged	Repair
	The deck motor electromagnetic switch (ES1) is damaged	Replace
	The deck motor fuse (F1) is open	Replace
	The motor carbon brushes are worn (replace).	Replace
	The motor is faulty	Repair or replace
	The wiring harness is damaged	Repair
The brush cannot be lifted/lowered		See the Electrical System chapter, function electronic board error codes
	The deck lifting/lowering actuator (M5) end-of-stroke microswitches are broken	Replace the actuator
	The deck lifting/lowering actuator (M5) is broken	Replace
	Open circuit in the actuator wiring harness	Check the connections according to the instructions in the Electrical System chapter, Troubleshooting paragraph
	The actuator fuse (F4) is open	Replace
	The function electronic board (EB1) is damaged	Replace
The BOOST® deck transmits too much vibration to the machine	The vibration of the deck are consumed	Replace

Removal and Installation

Removing and Installing the Brush Deck

Disassembly

6. Drive the machine on a level floor or on a hoisting system to facilitate the disassembly procedures.
7. Lower the BOOST® deck by pressing the scrub On/Off push button .
8. Turn the ignition key to "0" and disconnect the batteries.
9. Disconnect the hose (A) and the motor connector (B).
10. Remove the screw (C) and recover the nut.
11. Remove the screw (D), the nut (E) and recover the spacers (F).

12. Remove the screws (G), the nuts (H) and recover the spacers.
13. Disassemble the BOOST® deck (I) by pulling it toward the right side of the machine.

Assembly

14. Assemble the deck in the reverse order of disassembly, and note the following:
 - When tightening the screws (G), apply Loctite on threads.
 - Tighten the screw (D) until it goes beyond the Teflon nut (E). The screw (D) must rotate freely.
 -



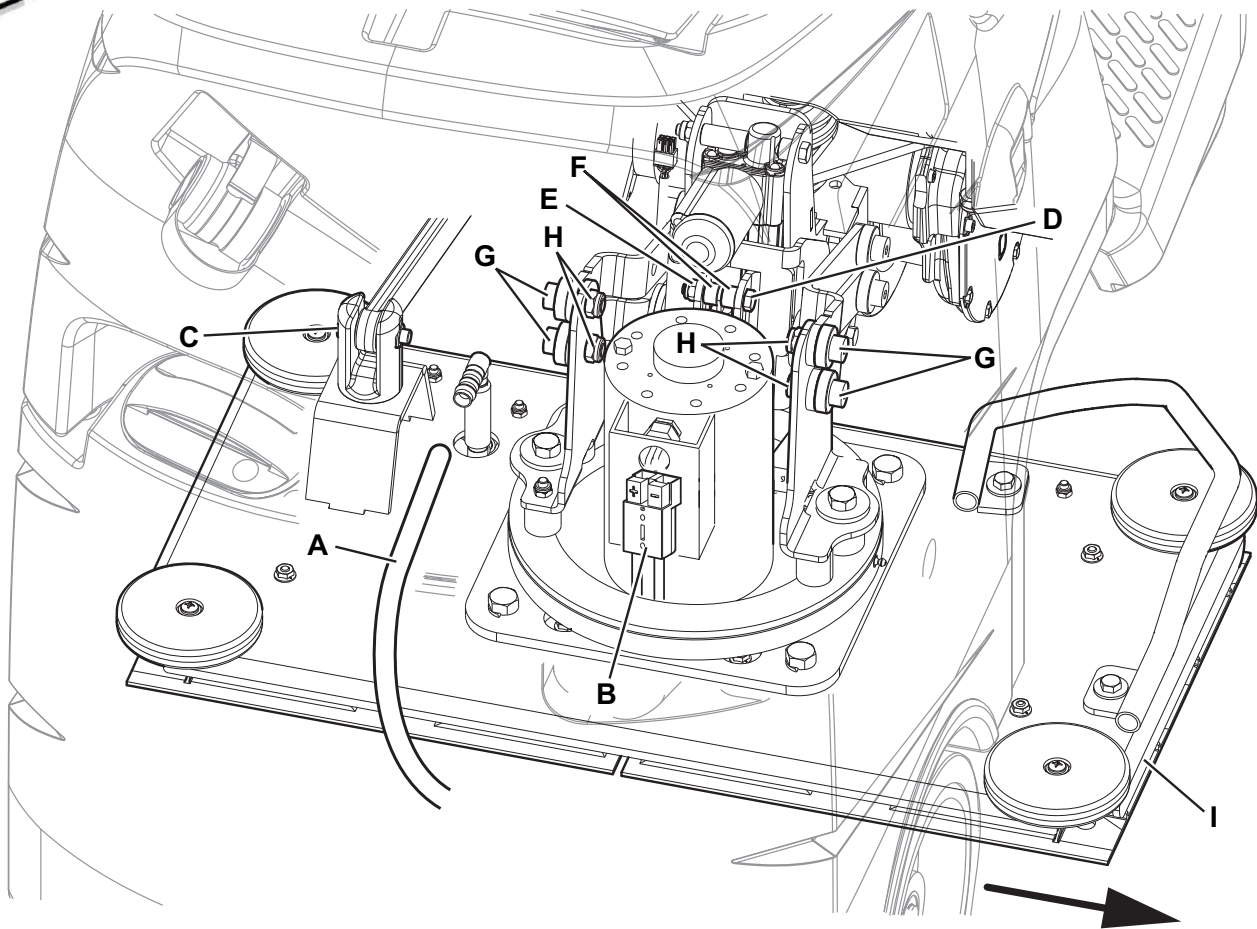

Note: For further information on deck components see the Spare Parts List.



BOOST® motor electrical input check

Warning! This procedure must be performed by qualified personnel only.

15. Drive the machine on a level floor.
16. Use a jumper wire to disable the driver's seat microswitch.
17. Disconnect the driving wheel connector to disable the drive system.
18. Lower the BOOST® deck by pressing the scrub On/Off push button .
19. Apply the amperometric pliers on the brush motor cable.
20. Turn on the deck motor by pressing the drive pedal (4), then check that the motor electrical input is less than 20 A at 24 V.
21. Turn off the brushes by releasing the drive pedal (4) and lift the BOOST® deck by pressing the push button .
22. Turn the ignition key to "0".
23. Remove the amperometric pliers (A).
24. If the electrical input is higher, perform the following procedures to detect and correct the abnormal input:



Note: If the electrical input is higher than the maximum allowed value, the 3 battery warning lights  flash simultaneously.

- Check the tightening of F1 fuse screw (see the procedure in Fuse check/replacement paragraph).
 - Check the motor carbon brushes (see the procedure in the relevant paragraph).
 - Remove the motor (see the procedure in the BOOST motor carbon brush check/replacement paragraph), and check the condition of all its components.
25. If the above-mentioned procedures do not lead to a correct electrical input, the motors must be replaced (see the procedure in the BOOST motor carbon brush check/replacement paragraph).

Reset

26. Connect the driving wheel connector.
27. Remove the jumper wire and enable the driver's seat microswitch.

BOOST® Motor Carbon Brush Check/Replacement

1. Remove the BOOST® deck (see the procedure in the relevant paragraph).
2. Place the deck on a workbench.



Note: The motor cannot be disassembled with BOOST® deck installed on the machine.

3. Remove the connector holder.
4. Remove the wire mounting nut and the rubber gasket.



P100472

5. Remove both nuts.

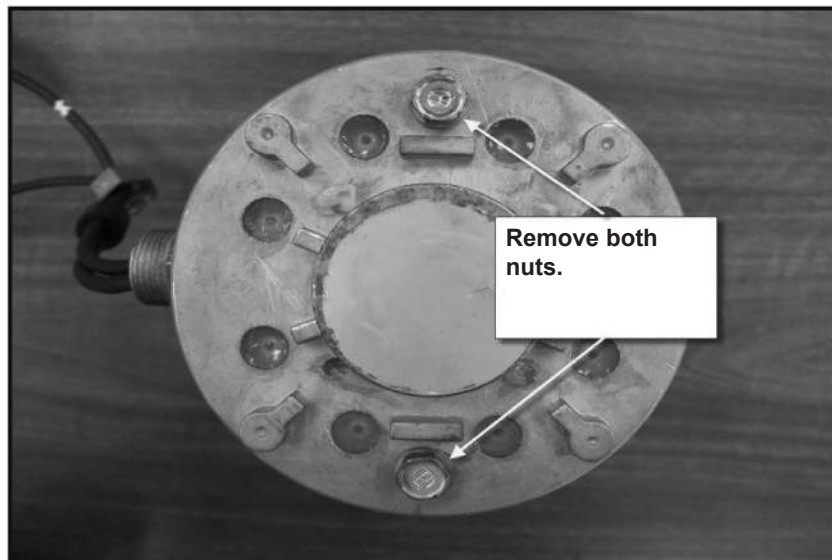

P100473

BOOST® Motor Carbon Brush Check/Replacement (continues)

6. Remove the top cover.



P100474

7. Replace the carbon brushes.
- Before disassembly, note the spring position when the carbon brush is being pushed back.
 - Remove the carbon brush and the spring.
 - Install the new carbon brush and the spring in the proper carbon brush housing. Route the wire through the carbon brush housing. Place the rear end of the carbon brush in the spring “cup” so that the spring unrolls with the carbon brush pushed back once installed.

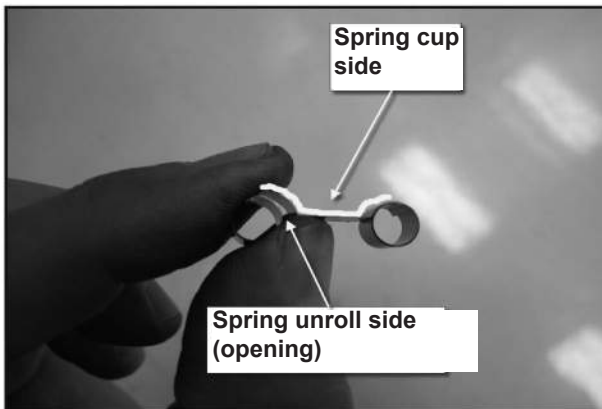

P100475

- Push the carbon brush against the spring and insert a temporary stiff wire (paper clip) through the access hole of the deck. (Remove the silicone sealant from the holes). The wire must pass through the holes of the brush holder in front of the brush to press the carbon brush against the spring.

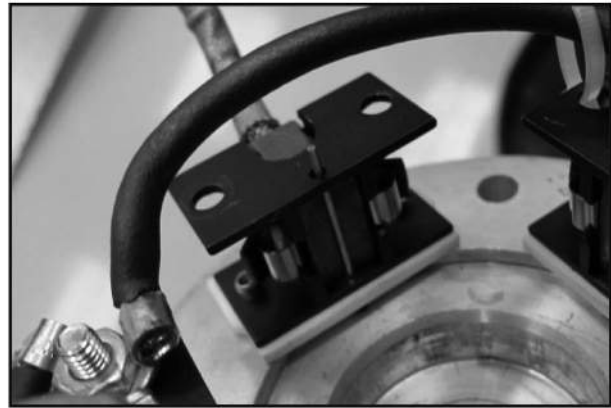
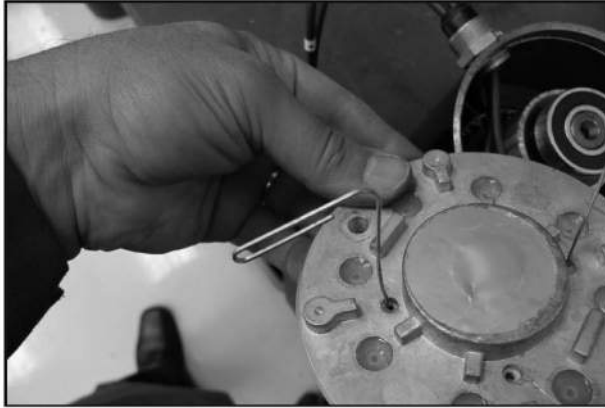
BOOST® Motor Carbon Brush Check/Replacement (continues)

P100476

- Install the other three carbon brushes.
8. Install the wave washer.
 9. Install the top cover.
 - Install it far enough so that the carbon brushes make contact with the collector when the temporary support wires are removed. Then remove the temporary wires.

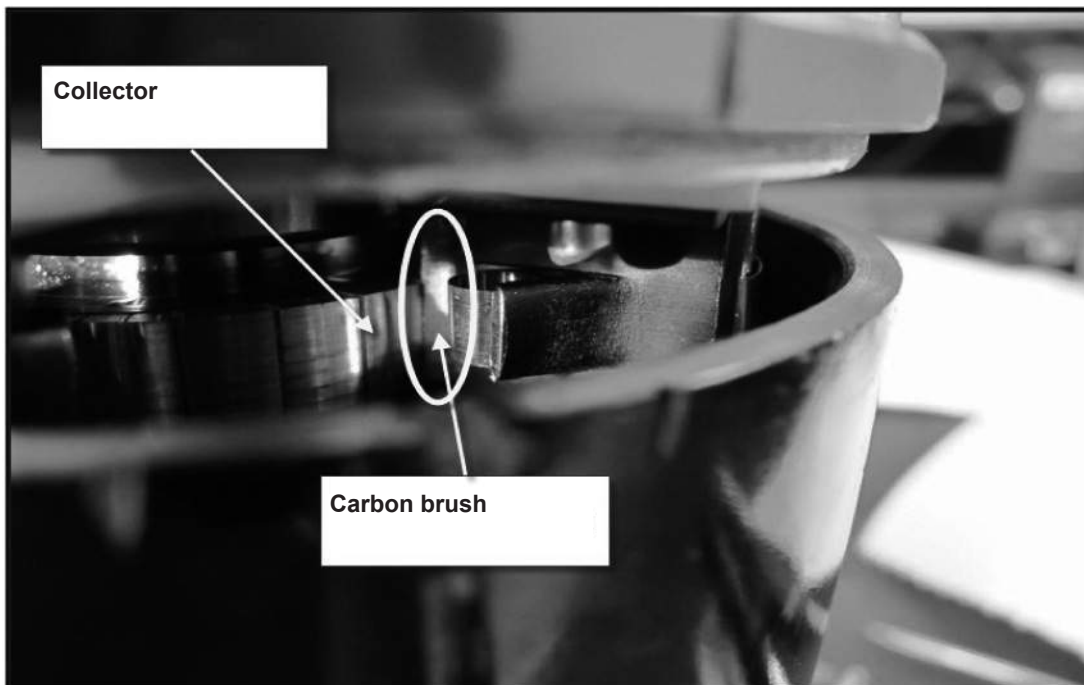

P100477

- Install the top cover.
- Install the nuts.
- Seal the wire mounting holes with silicone sealant.

BOOST® deck Motor Disassembly/Assembly**Disassembly**

1. Remove the BOOST® deck from the machine
2. At the workbench, remove the screw (A), recover the washer and remove the locking eccentric disc (B).
3. Remove the screws (C), recover the washers and lift the motor holder assembly (D).
4. Recover the spacer (E) and the key (F).
5. Remove the screws (G), then remove the motor (H).
6. Recover the connector holder (I).

Assembly

7. Assemble the components in the reverse order of disassembly, and note the following:
 - Install the motor rotated as shown in the figure.
 - Tighten the screws (G) at 14.7 lbf/ft (20 N/m, 2.0 kgf/m).
 - When tightening the screws (C) and (A), apply Loctite on threads.
 - When tightening the screw (A), use an impact driver.



Note: For further information on deck components see the Parts List.

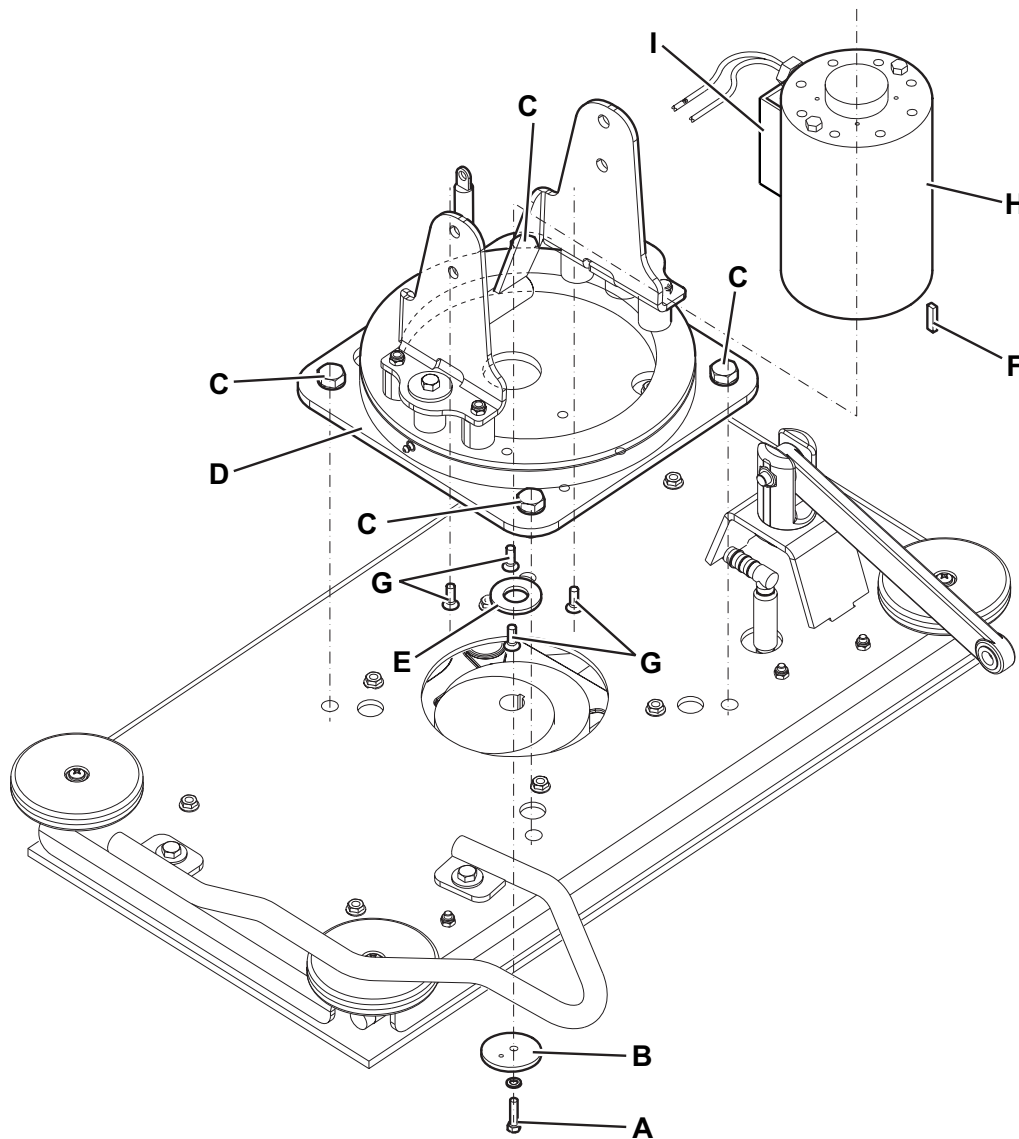

BOOST® deck vibration-dampers disassembly/replacement

1. remove the BOOST® deck from the machine.
2. At the workbench, remove the screw (A), recover the washer and remove the locking eccentric disc (B).
3. Remove the screws (C), recover the washers and lift the motor holder assembly (D).
4. Recover the spacer (E) and the key (F).
5. Remove the nuts (G), lift the deck holder assembly (H) and recover the washers.
6. Remove the vibration-dampers (I) from the pad holder stays (J).
7. Assemble the new vibration-dampers in the reverse order of disassembly, and note the following:
 - Add Loctite on the lower thread and manually install the vibration-dampers (I) on the pad holder stays (J).
 - Apply Loctite on the top thread of the vibration-dampers (I).
 - Tighten the nuts (G) at 8.8 lbf/ft (12 N/m, 1.22 kgf/m).
 - When tightening the screws (C) and (A), apply Loctite on threads.
 - When tightening the screw (A), use an impact driver.

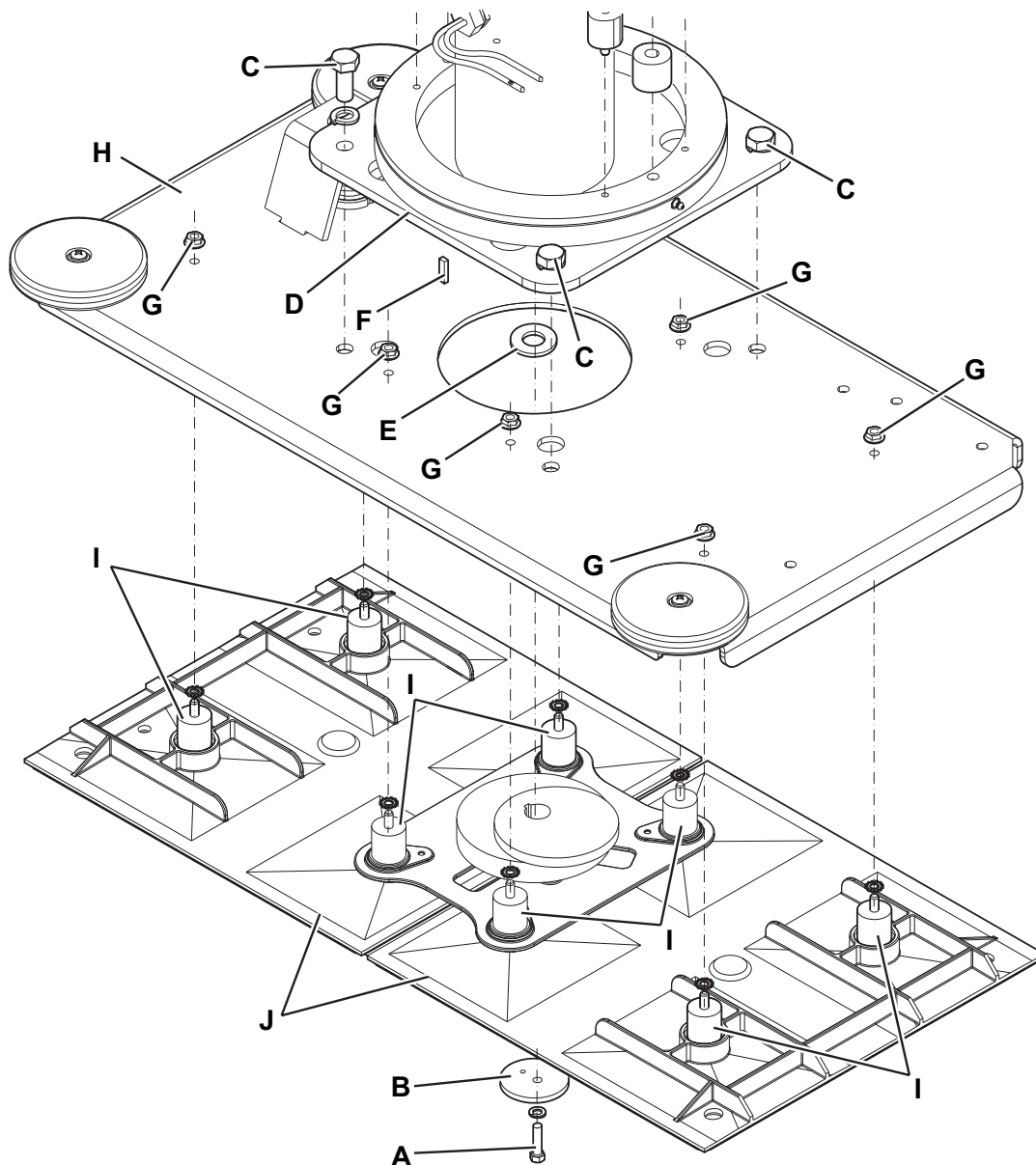

BOOST® deck vibration-dampers disassembly/replacement (continues)

8. Remove the screws (K) and recover washers and spacers (L).
9. Remove the nuts (M) and lift the stay assembly (N).
10. Remove the vibration-dampers (O) by unscrewing them from the ring (P).
11. Assemble the new vibration-dampers in the reverse order of disassembly, and note the following:
 - Apply Loctite on the lower thread and manually install the vibration-dampers (O) on the ring (P).
 - Apply Loctite on the top thread of the vibration-dampers (O).
 -



Warning! After assembly, the red band on vibration-dampers (O) must be straight.



Note: For further information on deck components see the Spare Parts List.

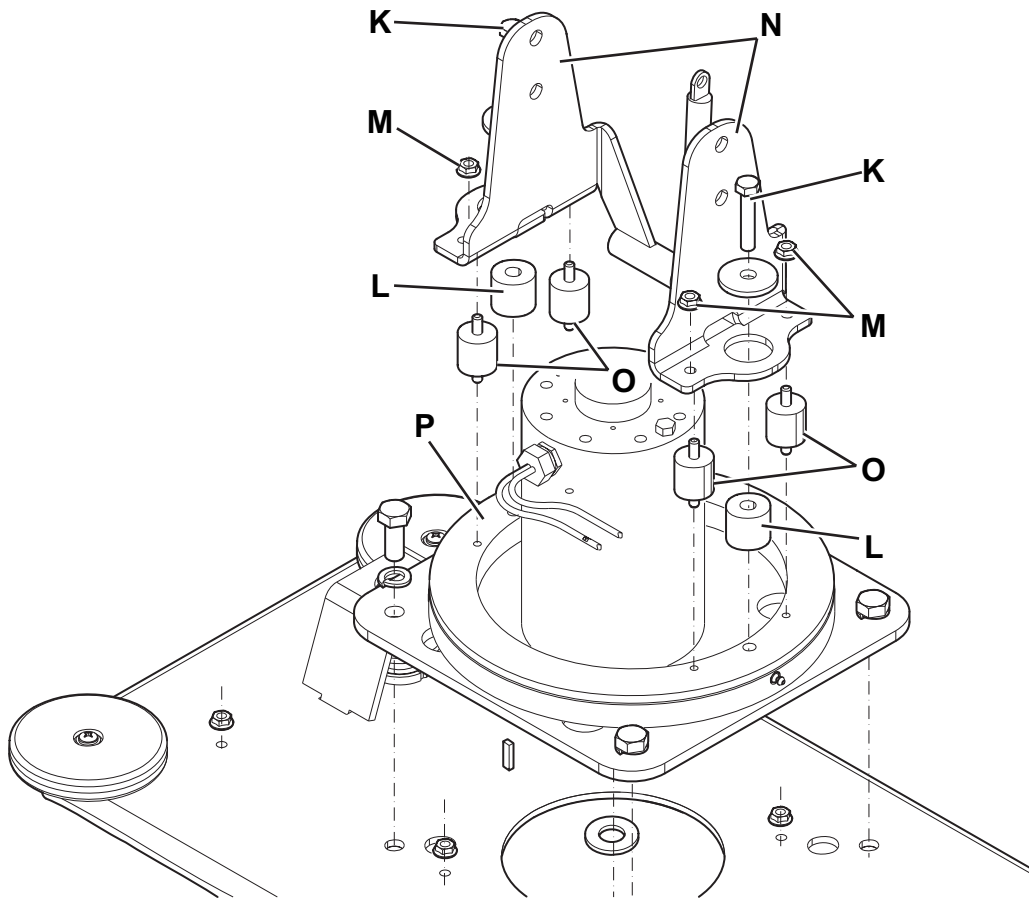

BOOST® Deck Lifting/Lowering Actuator Disassembly/Assembly

Disassembly

1. Lower the BOOST® deck.
2. Remove the BOOST® deck.
3. Turn the ignition key to “0” and disconnect the batteries.
4. Disconnect the actuator connector (see the function electronic board).
5. Remove the screw (A) and recover nuts, bushings and washers.
6. Remove the screw (B) and recover the washer.
7. Remove the actuator (C).

Assembly

8. Assemble the components in the reverse order of disassembly.

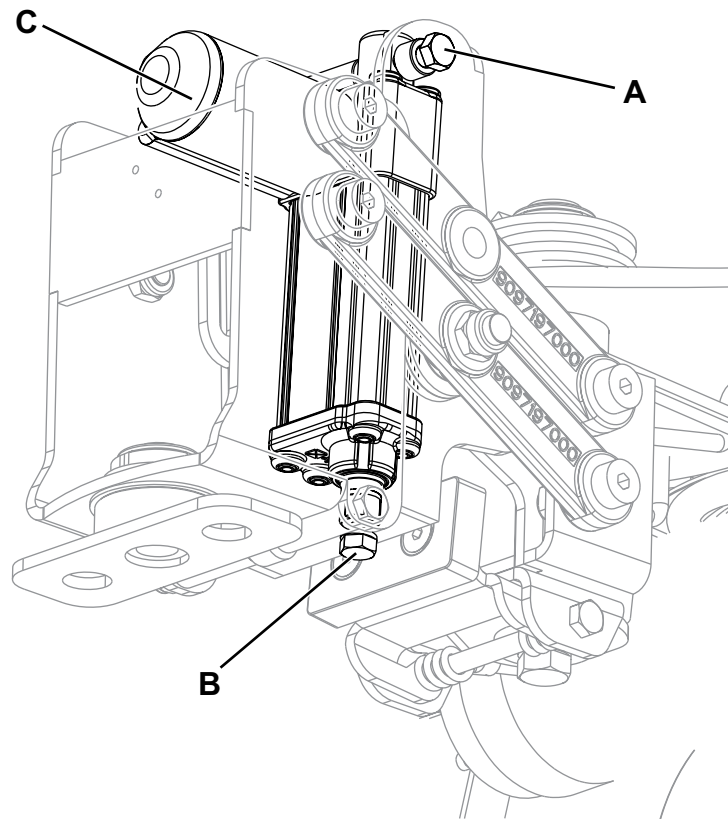

BOOST® Deck Adjuster Spring Disassembly/Assembly

Disassembly

1. Drive the machine on a level floor.
2. Remove the BOOST® deck.
3. Turn the ignition key to “0” and disconnect the batteries.
4. Remove the front fairing (see the procedure in “Front Fairing Disassembly/Assembly” paragraph, Steering System section).
5. Place a wooden shim (A) under the deck holder assembly. Wooden shim thickness must be 160 mm.
6. Unscrew the ring nut (B), recover the washer, then carefully remove the spring (C).
7. If necessary, replace the spring taking care to properly place the elastic ends (D) on the frame.

Assembly

8. Assemble the components in the reverse order of disassembly, and note the following:
 - Tighten the ring nut (B) so that the deck holder assembly can turn freely.

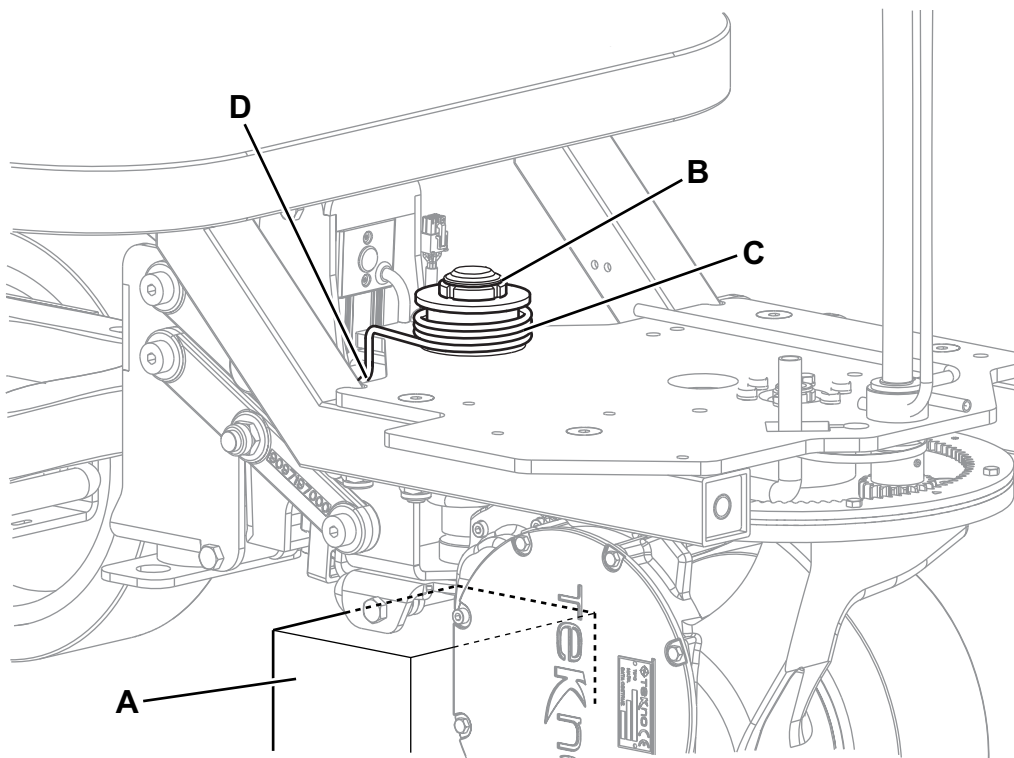

BOOST® Deck Drive Guide Disassembly/Assembly

Disassembly

1. Drive the machine on a level floor.
2. Remove the BOOST® deck and leave the deck holder assembly lifted.
3. Turn the ignition key to “0” and disconnect the batteries.
4. Turn the steering wheel to accommodate the position of the drive guide (A) to be removed.
5. Under the machine, remove the screws (B) and the drive guide (A).
6. Replace the drive guide if it is too worn.

Assembly

7. Assemble the components in the reverse order of disassembly.

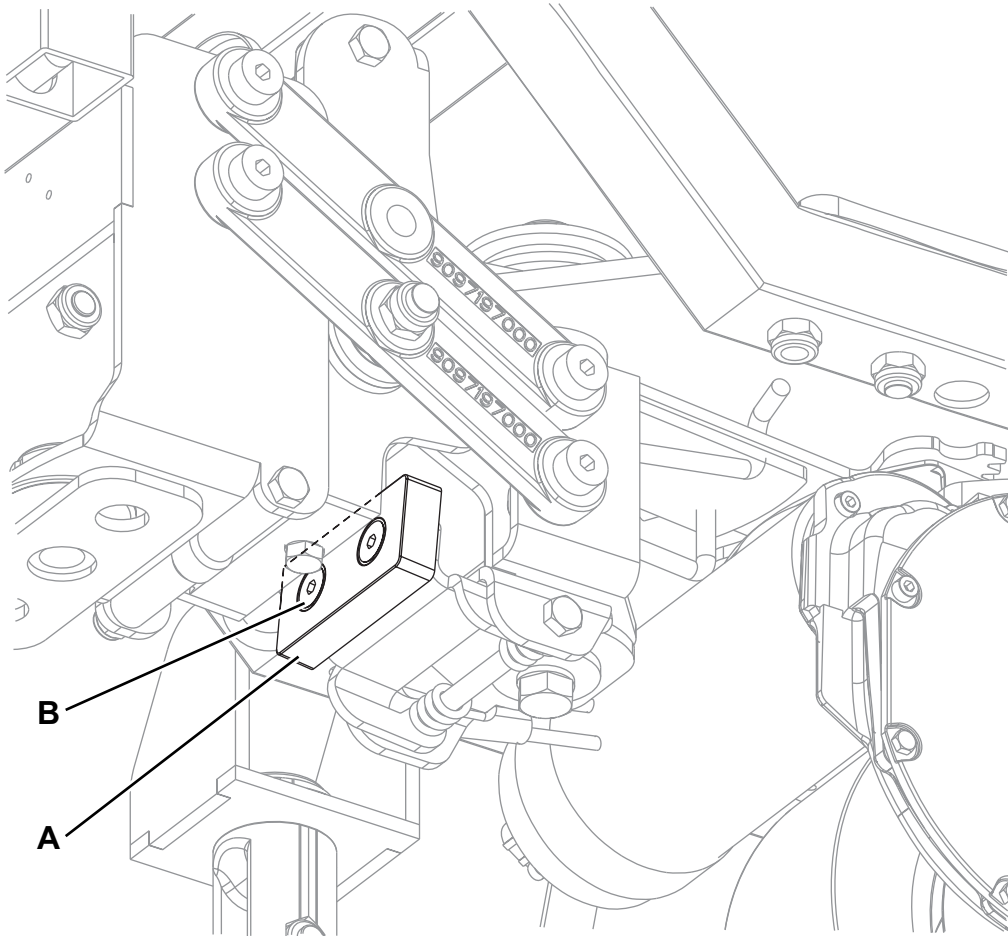

Specifications

Description		SCRUBTEC BOOST® R4 - FOCUS II Micro Rider 28 BOOST
Pad size		28 x 14 in (711 x 355.6 mm)
Weight without batteries and with empty tanks		401 lb (182 kg)
Maximum weight with batteries, full tanks and operator (GVW)		1,005 lb (456 kg)
Hourly efficiency (2.5 mph (4 km/h))		~ 26,909 ft ² (~ 2,500 m ²)
Deck right/left offset (variable)		0 ÷ 8.6 in / 4.9 ÷ 0 in (0 ÷ 220 mm / 125 ÷ 0 mm)
BOOST® deck distance from the floor (when lifted)		1.9 in (48 mm)
BOOST® deck motor power		0.75 hp (560 W)
Motor speed		2,200 giri/min
BOOST® deck pressure with extra-pressure function turned off		66 lb (30 kg)
BOOST® deck pressure with extra-pressure function turned on		105.8 lb (48 kg)
Actuator technical data	Maximum load	700 N
	Maximum speed	0.6 in/sec (16 mm/s)
	Voltage	24V
	Protection class	IP 65
Gas spring technical data	Stroke	2 in (50 mm)
	Strength	180 N

Solution System

Functional Description

The solution system supplies water and detergent to the brushes when cleaning the floor. The solution tank is also the main machine body. There is a manual valve on the right side of the tank to close the water supply whenever maintenance must be performed on the machine. The solution flows from the tank to the tap, through the filter and solenoid valve (EV1) and then to the brush deck.

The detergent pump (M4) installed only on Chemical Mixing System, controls the detergent flow from the Chemical Mixing System tank and pipes the flow into the main hose after the solenoid valve (EV1).

There is a one-way valve between the Chemical Mixing System pump and the connection with the main hose. The Chemical Mixing System can be selected with the specific lever under the steering wheel.

The operator sets the amount of detergent with the keys on the serigraphed electronic board installed on the steering wheel.

There is a manual valve under the tank in a central position, which can be used to drain any liquid in the battery compartment. There is also a manual valve on the left side, which can be used to drain the detergent when cleaning the tank.

The solution flow is regulated by different ON/OFF cycling timings depending on:

- Water flow setting (0 ÷ 4)
- Solution tank water level.

Both Solenoid valve and Detergent pump (when EDS system is enabled) follow the same above timings.

The Solenoid valve and the detergent pump are running only when needs the following conditions/inputs:

- Seat microswitch closed
- Brushes function enabled
- Drive pedal pressed
- Battery level not in red light blinking condition.

Wiring Diagram

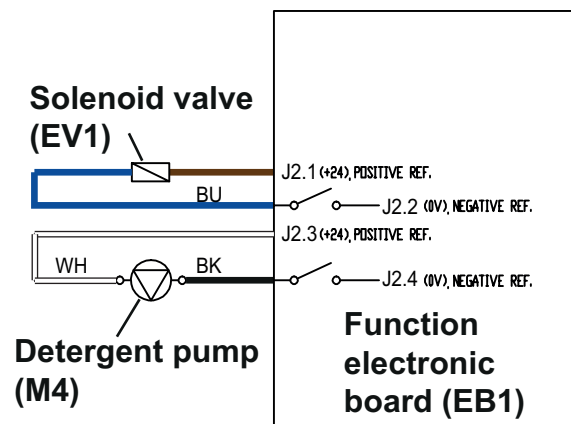

Component Location

- Solution/clean water tank
- Filling cap
- Solution/clean water valve
- Solution filter
- Solenoid valve (EV1)
- Chemical Mixing System detergent tank
- Chemical Mixing System detergent pump (M4)
- One-way valve
- Solution/clean water drain valve
- Battery compartment fluid valve



P100744

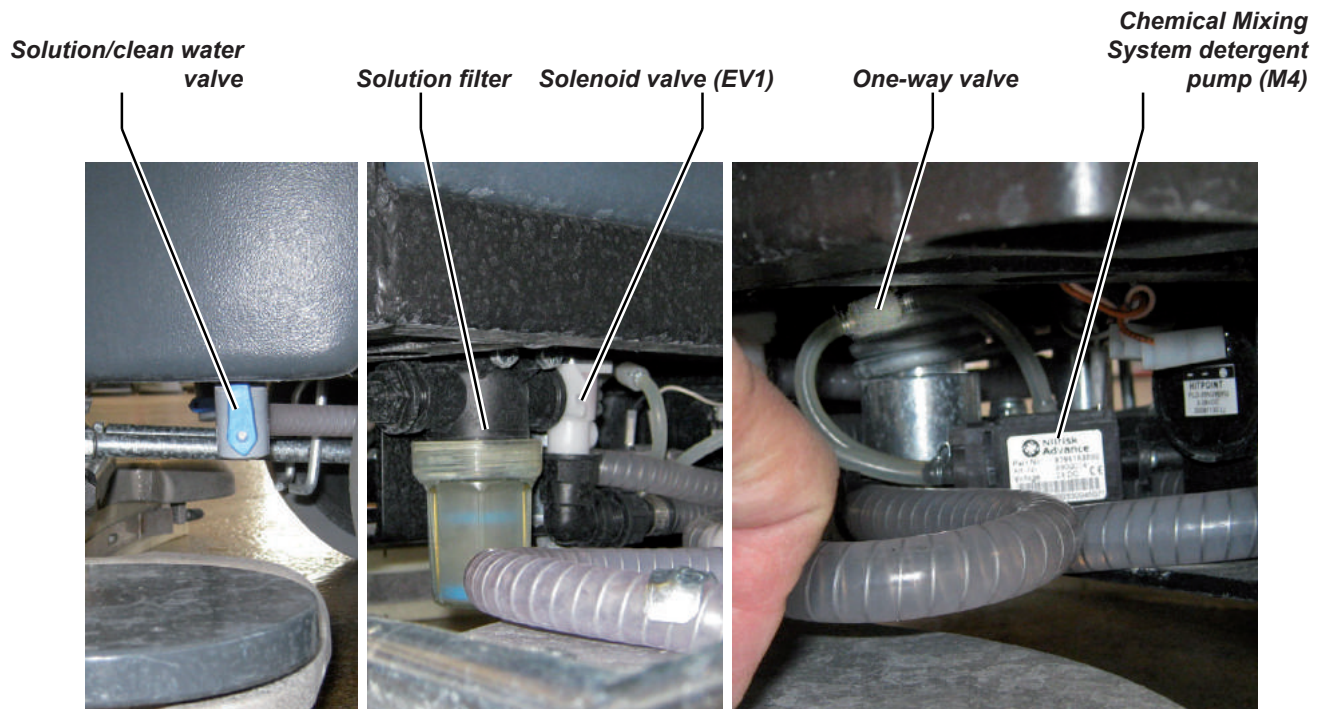

P100745

Maintenance and Adjustments

Solution/clean water tank emptying

1. Drive the machine to the appointed disposal area.
2. Turn the ignition key to “0”.
3. Remove the adapter from its housing inside the battery compartment.
4. Install the adapter (A) on the squeegee vacuum hose (B), then fasten it to the drain valve (C).
5. Turn the ignition key to “I” and turn on the vacuum system with the vacuum system push button .
6. Open the drain valve (C) to drain the tank.
7. The valve (C) is open when it is in the position (D) and it is closed when it is in the position (E).
8. Then, turn of the vacuum system and drain the recovery tank with the hose.
9. Close the drain valve (C), remove the adapter (A) and install the vacuum hose (B) on the squeegee.

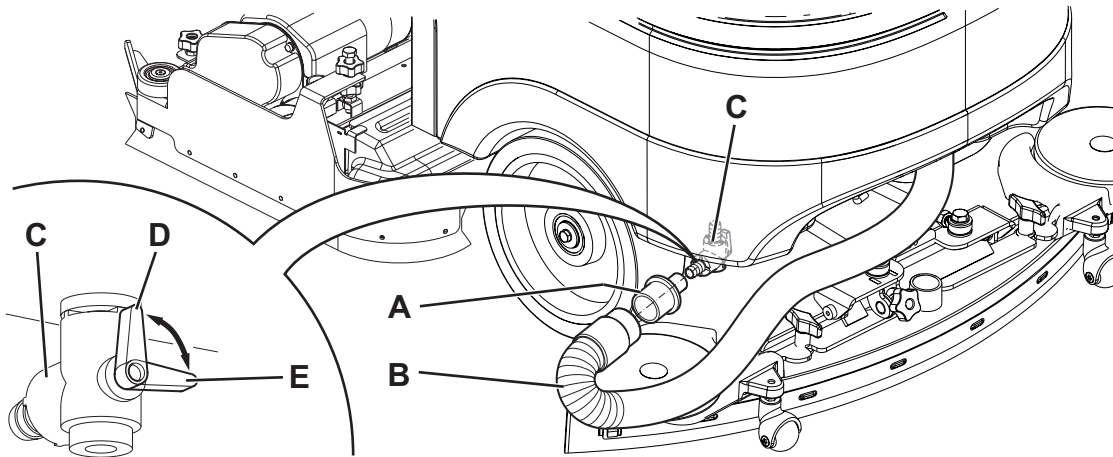

P100746

Solution filter cleaning

1. Drive the machine on a level floor.
2. Turn the ignition key to “0”.
3. Close the solution valve (A) under the machine, behind the right rear wheel. The valve (A) is closed when it is in the position (B) and it is open when it is in the position (C).
4. Remove the transparent cup (D), recover the gasket (E), then remove the filter strainer (F) under the machine, in front of the right rear wheel. Clean them with water and install them on the support (G).





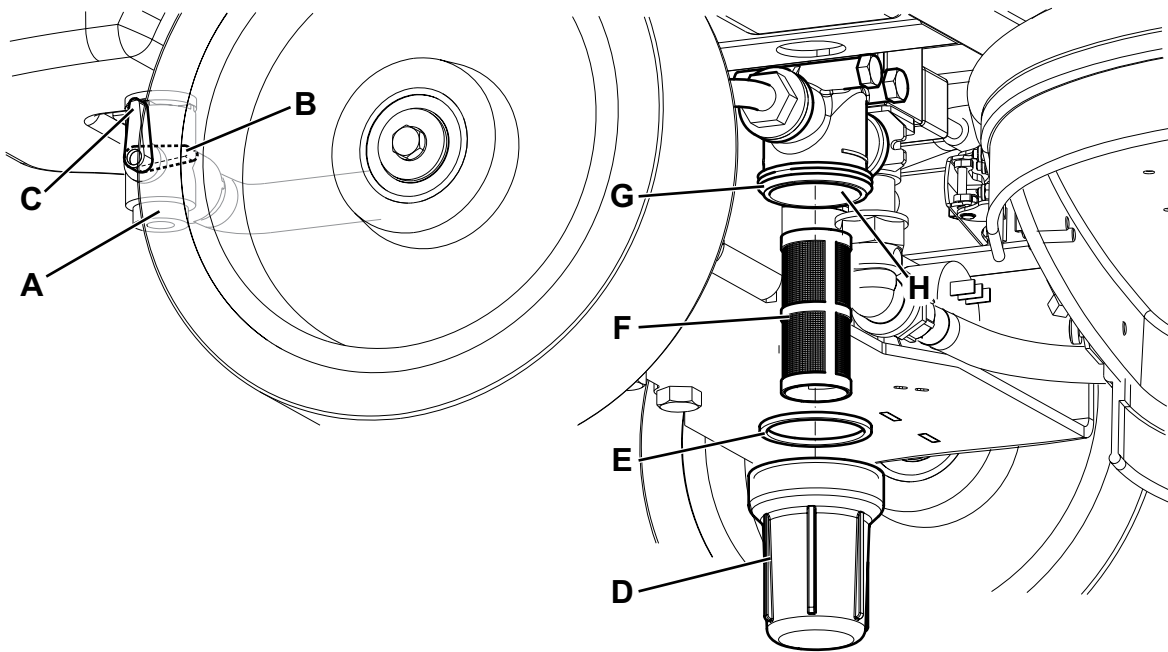

Note: The filter strainer (F) must be correctly positioned on the housing of the support (G).

5. Open the valve (A).



P100747

Chemical Mixing System Draining

1. To remove the detergent remained in the hoses and in the pump, perform the following procedure.
2. Turn on the machine by turning the ignition key to “I”.
3. Press the detergent concentration control push button . Check that the push button LED turns on.
4. Press the detergent concentration control push button  and the solution flow increase push button  at the same time, until the push button LED  starts flashing (after about 5 seconds).
5. Release the switches and wait for the detergent flow control push button LED  to stop flashing and for the vacuum system to turn on.
6. Collect the detergent remained on the floor.
7. Turn the ignition key to “0”.
8. Lift the recovery tank, then check that the detergent tank hose is empty, otherwise perform steps 3 to 7 again.



Note:

The draining cycle lasts about 30 seconds, then the vacuum function automatically turns on, which allows to remove the detergent remained. The draining cycle can also be performed with the detergent tank full of water, thus cleaning the system thoroughly. It is advisable to perform this type of draining to clean the Chemical Mixing System from dirt and deposits if the machine has not been used/cleaned for a long time. The draining cycle can be performed also to quickly fill the detergent supply hose when the tank is full but the system is still empty. If necessary, the draining cycle can be repeatedly performed.

Troubleshooting

Trouble	Possible Causes	Remedy
Small amount of solution or no solution reaches the brush	The tank filter (optional) is clogged/dirty	Clean the filter
	The solution filter is clogged/dirty	Clean the filter
	The solution valve is closed/semi-closed	Replace the valve
	The solenoid valve (EV1) is broken or there is an open in the electrical connection	Replace the solenoid valve/repair the electrical connection
	There is debris in the solution/clean water tank clogging the output hole	Clean the tank
	There is debris in the solution/clean water hoses clogging the flow	Clean the hoses
	The function electronic board (EB1) is faulty	Replace
	The display electronic board (EB2) is faulty	Replace
	The dashboard electronic board (EB3) is faulty	Replace
The solution reaches the brush also when the machine is off	There is dirt or calcium deposit on the solenoid valve gaskets (EV1)	Clean the solenoid valve inner gaskets
	The solenoid valve (EV1) is broken	Replace the solenoid valve

Troubleshooting (continued)

Trouble	Possible Causes	Remedy
Small amount of Chemical Mixing System detergent or no detergent reaches the brush	The detergent flow percentage is too low	Check/change the percentage as shown in the User Manual
	The hydraulic circuit upstream of the detergent pump is not triggered	Check if the hose is filled and, if necessary, perform one or more draining cycles
	The pump (M1) is broken or there is an open in the electrical connection	Replace the pump/repair the electrical connection
	There is foreign material/debris in the detergent tank clogging the output hole	Clean the tank
	There is debris in the detergent hoses clogging the detergent flow	Clean the hoses
	The detergent flow control push button  is malfunctioning	Check that the LED turns on, otherwise replace the dashboard electronic board (EB3)
	The function electronic board (EB1) is faulty	Replace
	The display electronic board (EB2) is faulty	Replace
	The dashboard electronic board (EB3) is faulty	Replace
The Chemical Mixing System detergent reaches the brush also when the machine is off	The pump (M1) is broken	Replace
	The one-way valve is broken	Replace
There is water in the Chemical Mixing System tank	The one-way valve is broken	Replace
The Chemical Mixing System does not turn and the LED does not turn on	The dashboard electronic board (EB3) is faulty	Replace
	The function electronic board (EB1) is not set for the operation with Chemical Mixing System	If equipped, remove the jumper wire (J8) on the back of the electronic board

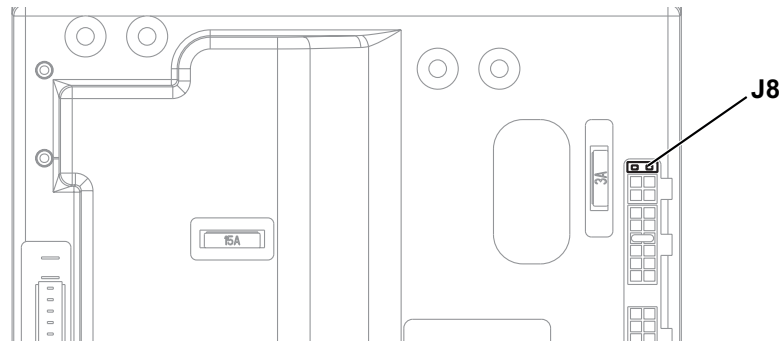

Removal and Installation

Solution System Solenoid Valve/Filter Disassembly/Assembly

Disassembly

1. Place the machine on a hoisting system (if available), then lift it. Otherwise, drive the machine on a level floor.
2. Lower the brush deck.
3. Lower and remove the squeegee from the holder.
4. Turn the ignition key to “0” and disconnect the batteries.
5. On the right side of the machine, remove the screws and nuts (A).
6. Disconnect the connector (B).
7. Disconnect the hose (C) and (D).
8. Recover the whole assembly and, at the workbench, remove the solenoid valve (E), or the filter assembly (F) by disconnecting/unscrewing the connecting/fastening components.

Assembly

9. Assemble the components in the reverse order of disassembly, and note the following:
 - Before screwing the threaded fittings (G) clean them, then apply Teflon tape, according to the screwing direction.
 - When assembling the filter (F) the stamped arrow (H) must be tuned in the direction of the solution flow.

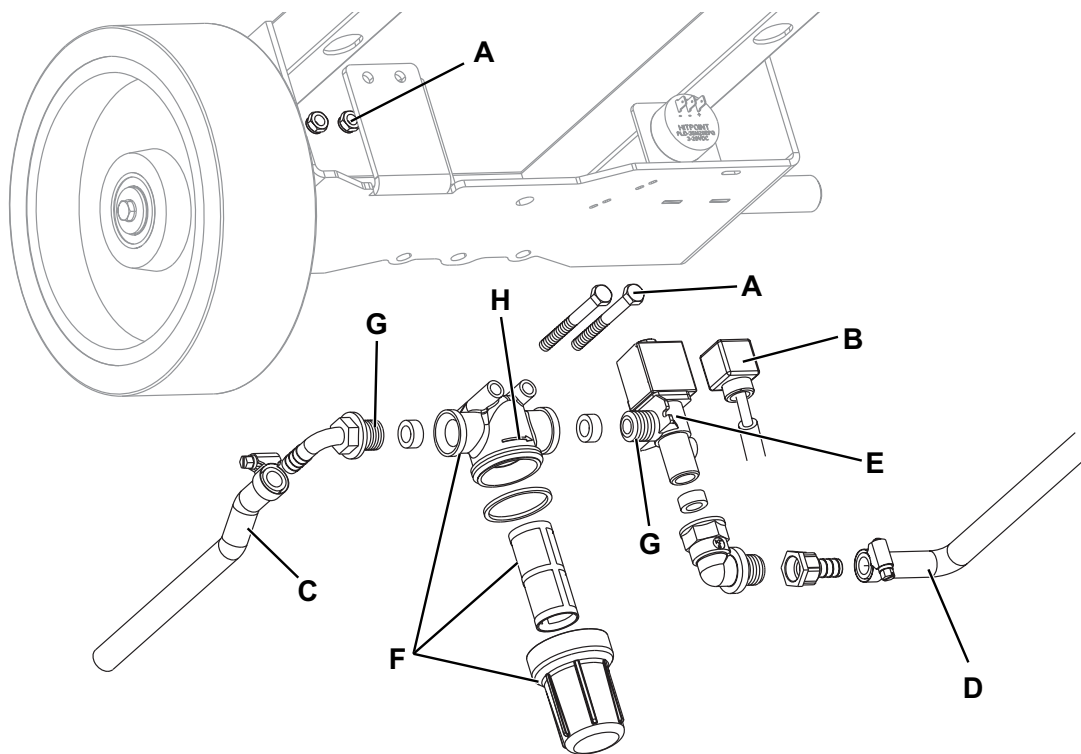

Detergent Pump And One-Way Valve Disassembly/Assembly

Disassembly

1. Place the machine on a hoisting system (if available), then lift it. Otherwise, drive the machine on a level floor.
2. Lower the brush deck.
3. Turn the ignition key to “0” and disconnect the batteries.
4. Open the detergent tank plug.
5. On the left side of the machine, remove the screws and nuts (A).
6. Disconnect the connectors (B) and (C).
7. Disconnect the hose (D).
8. Remove the detergent pump (E).
9. If necessary, remove the retaining springs (F) and disconnect the one-way valve (G) from the relevant hoses.

Assembly

10. Assemble the components in the reverse order of disassembly, and note the following:
 - Connect the connector with black cable (B) and white cable (C) as shown in the figure.
 - Install the one-way valve (G) with the arrow (H) turned in the direction of the detergent flow.

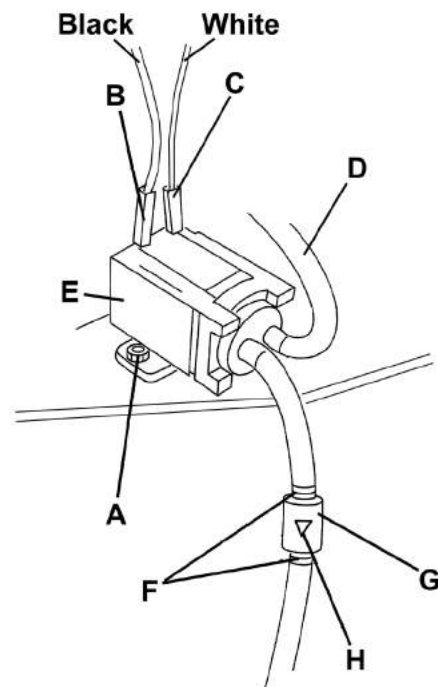
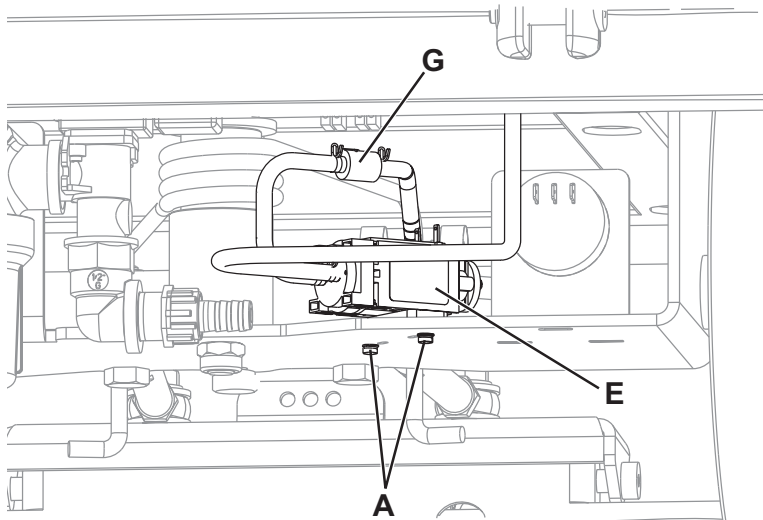

Specifications

Description	SCRUBTEC R 466 - FOCUS II Micro Rider 26D	SCRUBTEC R 471	SCRUBTEC R 471C	SCRUBTEC BOOST® R4 - FOCUS II Micro Rider 28 BOOST
Solution/clean water tank capacity	21 US gal (80 L)			
Solution flow	0.26 to 0.8 US gal/min. (1 to 3 L/min.)			
Min/max solution flow (with and without Chemical Mixing System)	0 ÷ 0.8 US gal/min. (0 ÷ 3 L/min.)			
Chemical Mixing System kit detergent concentration settings	0,4% - 0,75% - 1,5% - 2,5%			

Squeegee System

Functional Description

The squeegee system cleans the liquid off the floor, which is then collected by the recovery system.

The squeegee is mounted on castors and the weight of the system presses it down on the floor.

The squeegee is held in place by two quick-fit wing nuts in the squeegee support slots. In case of fixed obstacles, the quick-fit system allows for squeegee immediate removal.

The squeegee support is held on the frame by two tie rods and a centring spring, allowing some lateral movement.

The angle of the squeegee and the correct adherence of the blades on the floor can be adjusted with a knob.

The front blade has an opening in the bottom edge so the squeegee can collect the water on the floor. The design and the central duct make it easy for the squeegee to clear the water. The bottom edge of the blade is smooth.

All 4 functional edges of each blade can be used before it needs replacing.

The squeegee is lifted and lowered by a cable on a winch in the solution tank. It is activated at the same time as the brush deck.

The squeegee actuator (M6) has 2 limit microswitches (not accessible). Every time it is raised or lowered, the actuator is activated by the electronic board for 10 seconds. The squeegee must reach the correct limit switch by the end of this time.

In any case the electronic board cuts off the power supplied to the actuator after 10 seconds, to prevent damaging the actuator.

Wiring Diagram

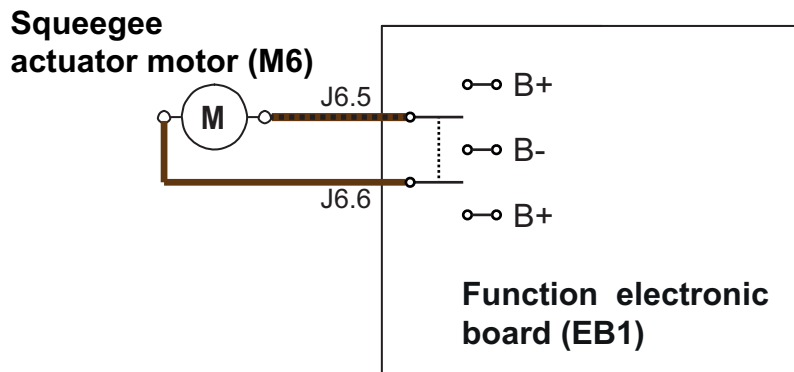

Component Location

- Squeegee
- Squeegee blades
- Squeegee holder
- Mounting handwheels
- Squeegee adjustment
- Actuator (M6)
- Squeegee lifting cable



Actuator (M6)



Maintenance and Adjustments

Squeegee cleaning



Note: The squeegee must be clean and its blades must be in good conditions in order to get a good drying.



Warning! It is advisable to wear protective gloves when cleaning the squeegee because there may be sharp debris.

1. Drive the machine on a level floor.
2. Insert the ignition key and turn it to "I".
3. Lower the squeegee by pressing the vacuum system push button .
4. Turn the ignition key to "0".
5. Disconnect the vacuum hose from the squeegee.
6. Loosen the handwheels and remove the squeegee.
7. Wash and clean the squeegee. In particular, remove dirt and debris from the compartments (A) and the hole (B). Check that the front blade (C) and the rear blade (D) are integral and free from cuts and lacerations; if necessary replace them.
8. Assemble in the reverse order of disassembly.

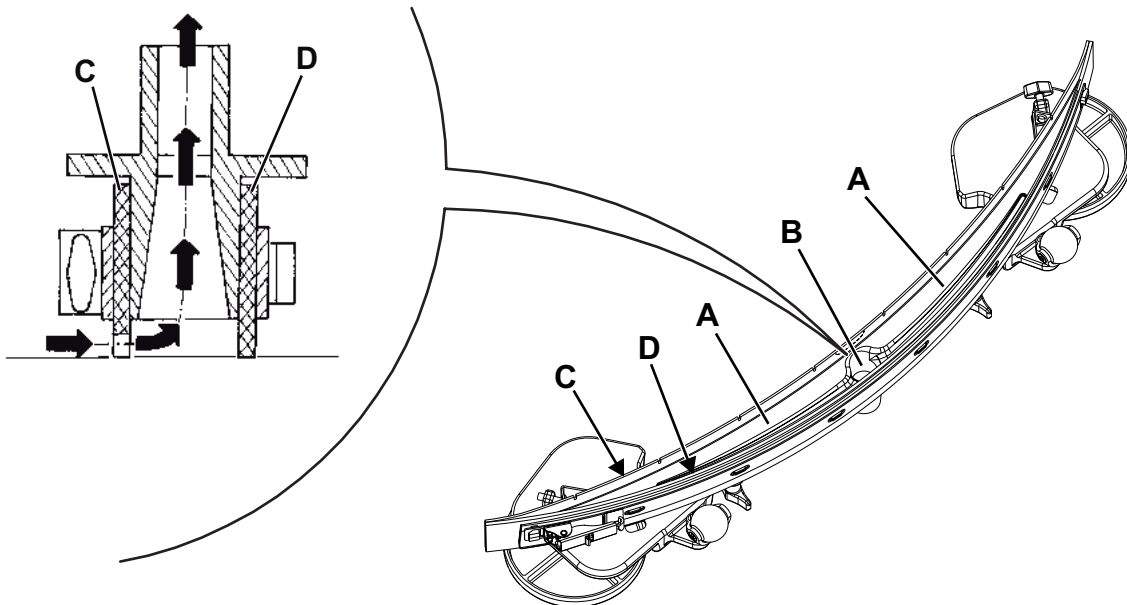

Squeegee blade check and replacement



Note: The squeegee must be clean and its blades must be in good condition in order to get a good drying.



Warning! It is advisable to wear protective gloves when cleaning the squeegee because there may be sharp debris.

1. Clean the squeegee as shown in the previous paragraph.
2. Check that the edge (E) of the front blade (C) and the edge (F) of the rear blade (D) lay down on the same level, along their length; otherwise adjust their height according to the following procedure:
 - Remove the tie rod (G), disengage the fastener (M) and adjust the rear blade (D); then engage the fastener and install the tie rod.
 - Loosen the handwheels (I) and adjust the front blade (C); then tighten the handwheels.
3. Check the front blade (C) and rear blade (D) for integrity, cuts and tears; if necessary replace them as shown below. Check the front corner (J) of the rear blade for wear; if necessary, overturn the blade to replace the worn corner with an integral one.
4. If the other corners are worn too, replace the blade according to the following procedure:
 - Remove the tie rod (G), disengage the fastener (M) and remove the retaining strip (K), then replace/overturn the rear blade (D).
 - Install the blade in the reverse order of removal.
 - Unscrew the handwheels (I) and remove the retaining strip (L), then replace the front blade (C).
 - Install the blade in the reverse order of removal.
4. After the blade replacement (or overturning), adjust the height as shown in the previous step.
5. Connect the vacuum hose to the squeegee.
6. Install the squeegee and screw down the handwheels.
7. If necessary, adjust the squeegee balance adjusting handwheel.

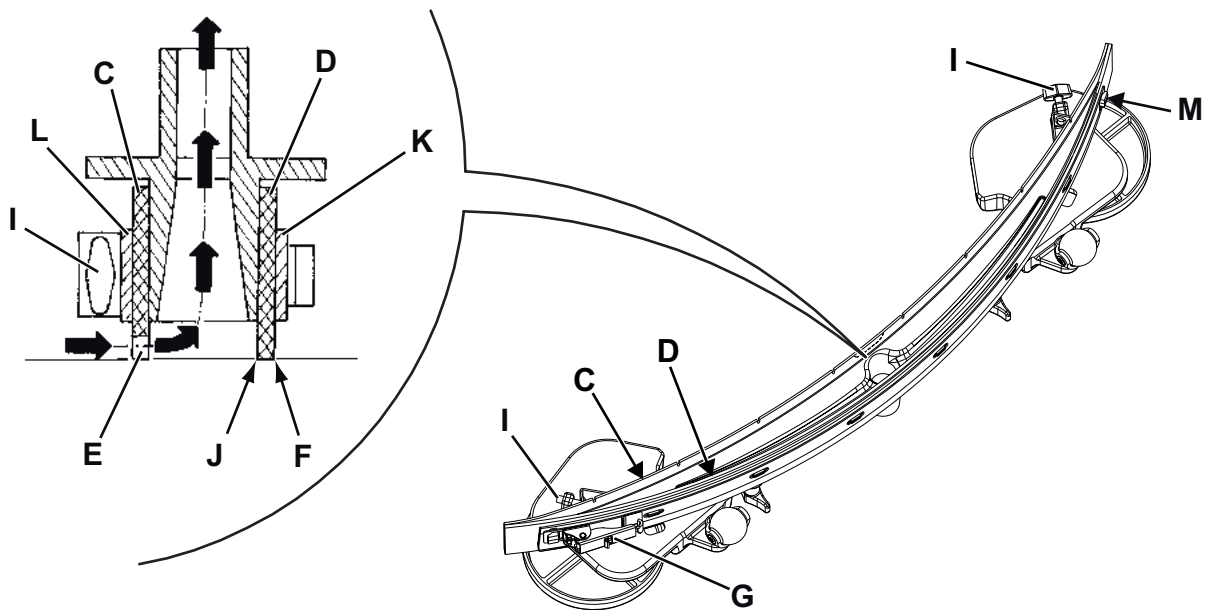

Troubleshooting

Trouble	Possible Causes	Remedy
Dirty water vacuuming is insufficient or there is no vacuuming	The squeegee or the vacuum hose is clogged or damaged	Clean or repair/replace
The squeegee leaves lining on the floor or does not collect water	There is debris under the blade	Remove
	The squeegee blade edges are torn or worn	Replace
	The squeegee is not balanced	Adjust with the relevant handwheel
The squeegee does not lift/lower		See the Electrical System chapter, function electronic board diagnosis.
	The cable is broken	Replace
	The actuator (M6) is faulty	Replace
	The actuator fuse (F4) is open	Replace

Removal and Installation

Squeegee Lifting Actuator Disassembly/Assembly

Disassembly

1. Lower the squeegee.
2. Turn the ignition key to “0” and disconnect the batteries.
3. Disengage the cable grommet (A) and remove it from the squeegee.
4. Remove the screws (B) and recover the washers.
5. Remove the screw (C) and recover the nut.
6. Disconnect the connector (D) and remove the squeegee lifting assembly (E).
7. At the workbench, remove the screw (F), recover the spacers and the nut.
8. Remove the squeegee lifting actuator (G).

Assembly

9. Assemble the components in the reverse order of disassembly.

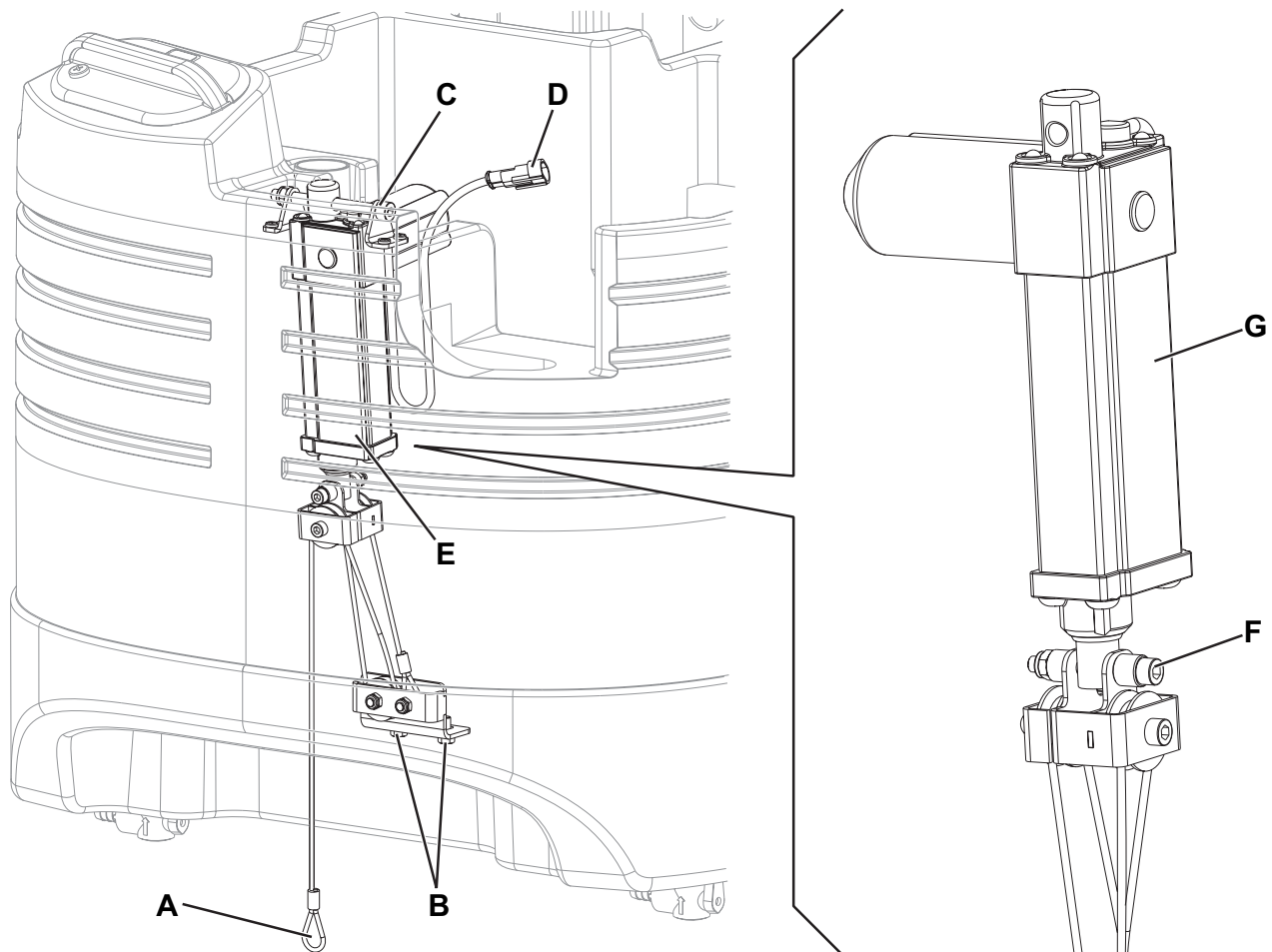

Squeegee Lifting Cable Disassembly/Assembly

Disassembly

1. Remove the squeegee lifting assembly (see the previous paragraph, steps 1 to 6).
2. At the workbench, remove the screw (A) and recover the nut.
3. Carefully remove the squeegee lifting cable (B) from the pulleys.

Assembly

4. Install the lifting cable and note the following:
 - Apply AGIP GR 30 grease or equivalent on the entire length of the cable.
 - Insert the cable in the direction shown by the arrow (C).
 - Route the cable in the pulleys (D), (E) and (F) in sequence.
 - Fasten the cable grommet with the screw (A) and nut.
5. The components must be carefully installed as shown in the figure for the proper operation of the lifting system.
6. Install the squeegee lifting assembly (see the previous paragraph).
7. Check the proper operation of the squeegee lifting system.



Note: The squeegee lifting system pulleys are self-lubricating and do not require maintenance.

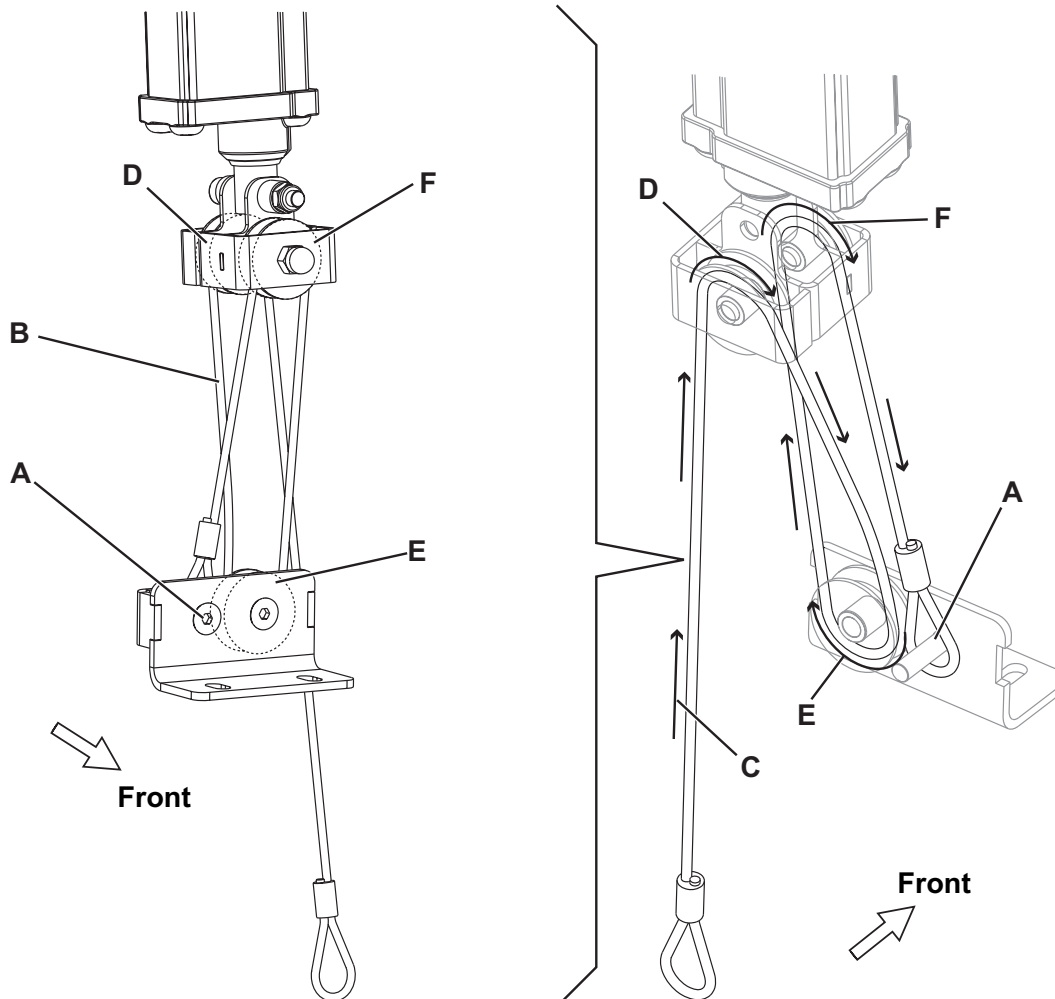

Specifications

Description		SCRUBTEC R 466 - FOCUS II Micro Rider 26D	SCRUBTEC R 471	SCRUBTEC R 471C	SCRUBTEC BOOST® R4 - FOCUS II Micro Rider 28 BOOST
Squeegee width		35 in (890 mm)			
Actuator technical data	Maximum load	500 N			
	Maximum speed	32 mm/s			
	Voltage	24V			
	Protection class	IP 65			
Actuator normal current draw	In lifting	Max 4 A			
	In lowering	Max 2 A			

Steering System

Functional Description

The steering system connects the steering wheel to the driving wheel assembly.

The reduction gear pinion transmits the movement to the steering crown connected to the driving wheel assembly. The driving wheel assembly is also equipped with the gear for “magic deck” system movement.

To reach the steering system, the machine front fairing must be removed.

Component Location

- Steering column
- Front fairing

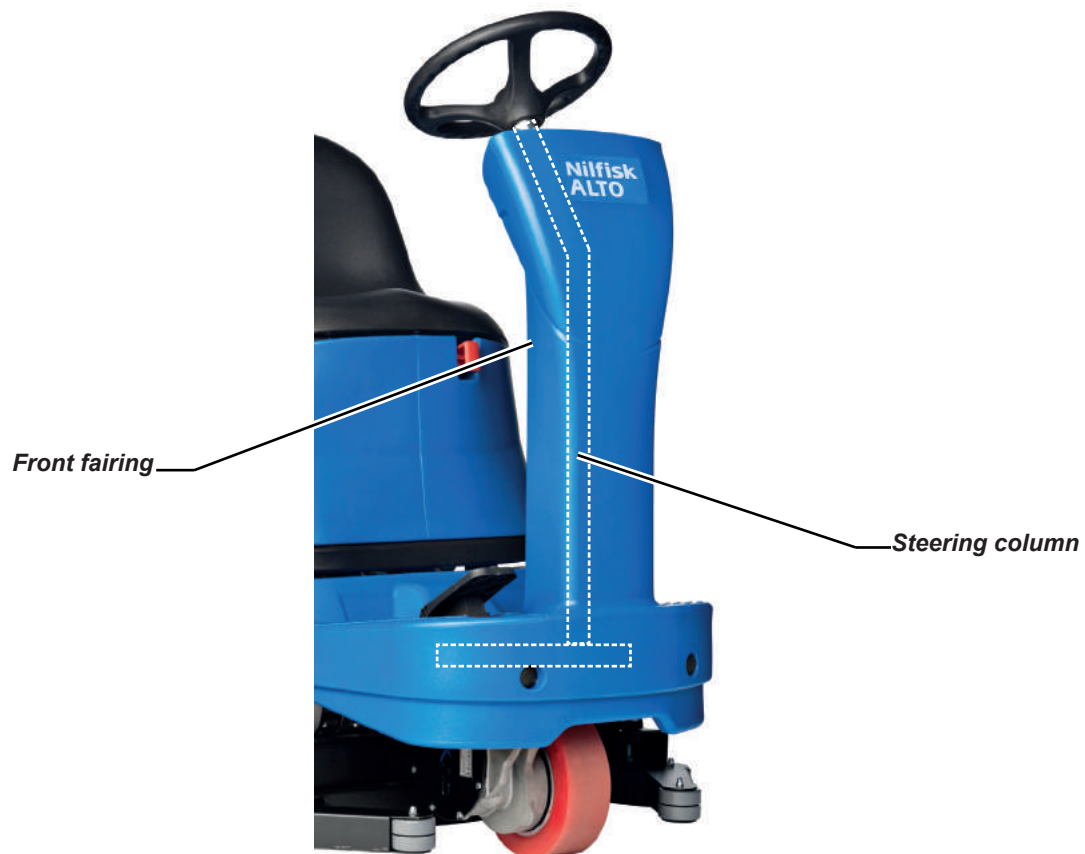

Removal and Installation

Front Fairing Disassembly/Assembly

Disassembly

1. Drive the machine on a level floor with the recovery tank empty.
2. Turn the ignition key to “0” and disconnect the batteries.
3. Unscrew the steering wheel height control lever (A).
4. Remove the steering wheel assembly (B), disconnect the wiring harness connection.
5. Remove the cover (C), then remove the Seeger ring (D).
6. Remove the caps, the screws (E) and the steering wheel plate (F).
7. Disconnect the ignition switch wiring harness.

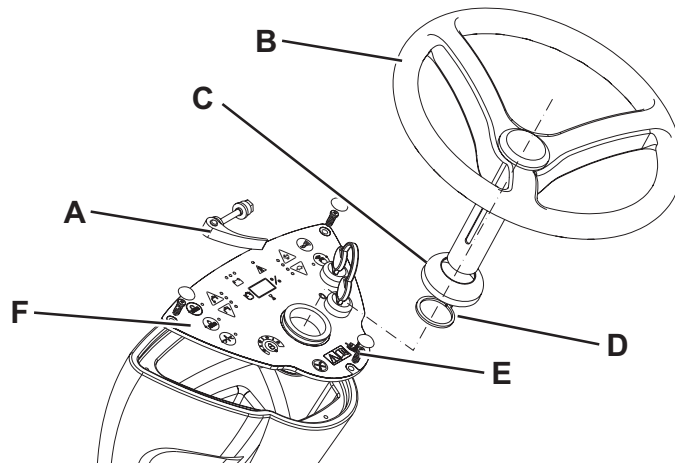

P100757

Front Fairing Disassembly/Assembly (continued)

8. Remove the screws (G), recover the washers, disconnect the wiring harness and then remove the drive pedal (H).
9. Remove the caps, the screws (I) on the machine front and recover the washers.
10. Remove the caps, the screws (J) on the machine foot board and recover the washers and the nuts.
11. Carefully remove the front fairing (K).

Assembly

12. Assemble the components in the reverse order of disassembly.

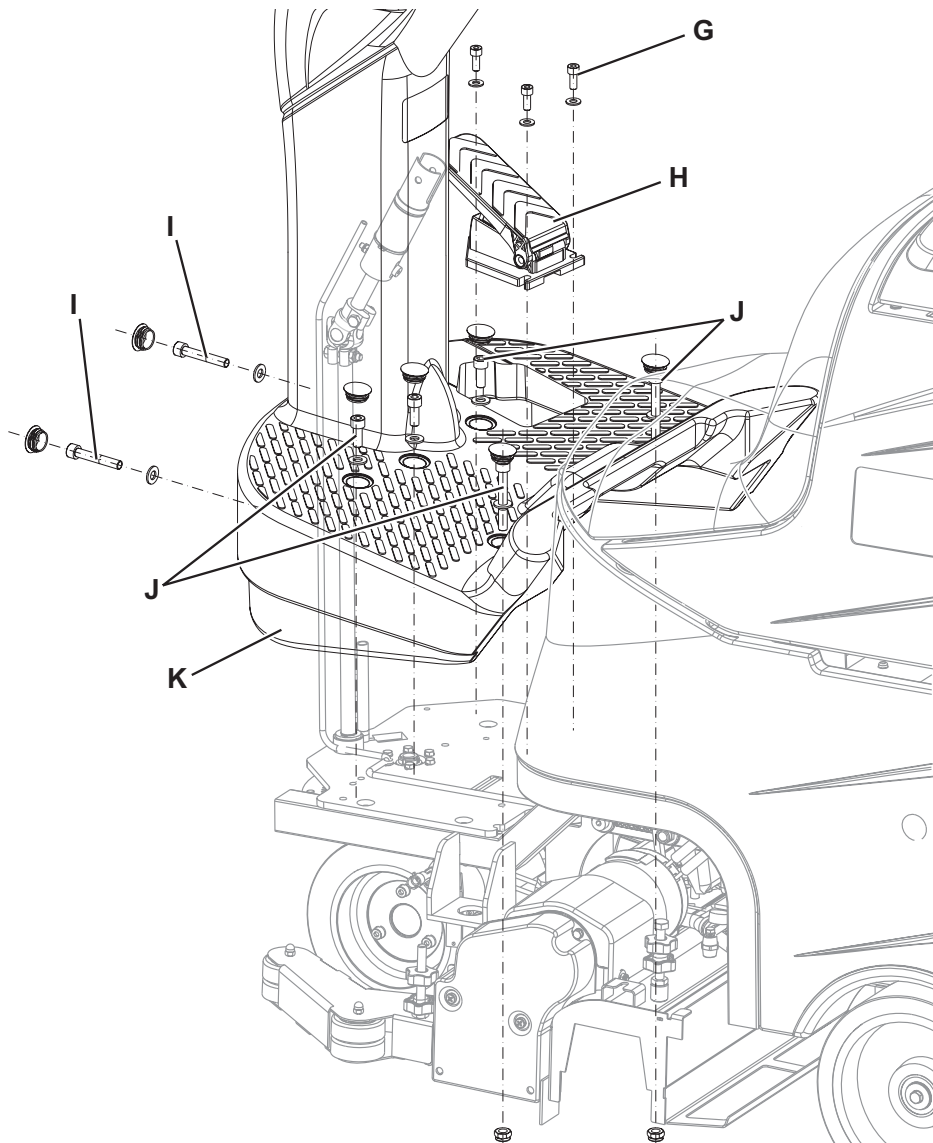

P100757

Wheel System, Driving

Functional Description

The driving wheel system moves the machine forwards.

The operator adjusts the operating speed with the accelerator (RV1). The reverse push button  are into control panel.

The driving wheel is connected to the steering system. The electromagnetic brake is built into the drive system motor and keeps the machine braked when the machine is off or stopped.

An anti-skid system reduces the speed to a safe speed when turning and when the machine tilts laterally in order to avoid sudden skidding, thus increasing machine stability in all conditions.

The driver's seat microswitch is located inside the driver's seat and the machine drive system is only enabled if the operator is seated in the driver's seat.

The function electronic board (EB1) checks the drive pedal is not pressed when the machine is turned on. If it is pressed an alarm is generated (see paragraph "Function electronic board alarm codes" in chapter "Control system") and the drive system is disabled.

When the pedal returns to the rest position, the alarm is automatically deactivated (without having to turn the machine off and on again).

When the drive pedal is pressed, the function electronic board (EB1) powers the electromagnetic brake to release the wheel, then activates the driving wheel motor (M3) with a proportional voltage on the basis of the pedal position. The acceleration ramps and top speed can be set with the relevant parameters (see paragraph "Display and change of parameters which can be set by the user" in chapter "Control system").

Reverse is enabled when the reverse push button  is pressed. The signal is sent by the display electronic board (EB2) to function electronic board (EB1) like any other signal from a dashboard push-button.

The automatic anti-skid system constantly detects lateral acceleration using an accelerometer installed in function electronic board (EB1). If the lateral accelerometer detects a speed higher than the preset value (set using the AMAX parameter, see paragraph "Display and change of parameters which can be set by the user" in chapter "Control system") the system reduces the speed so the lateral acceleration remains below this limit.

The speed indicator LED  indicates the system is automatically reducing the speed to below that controlled by the accelerator pedal position.

Wiring Diagram

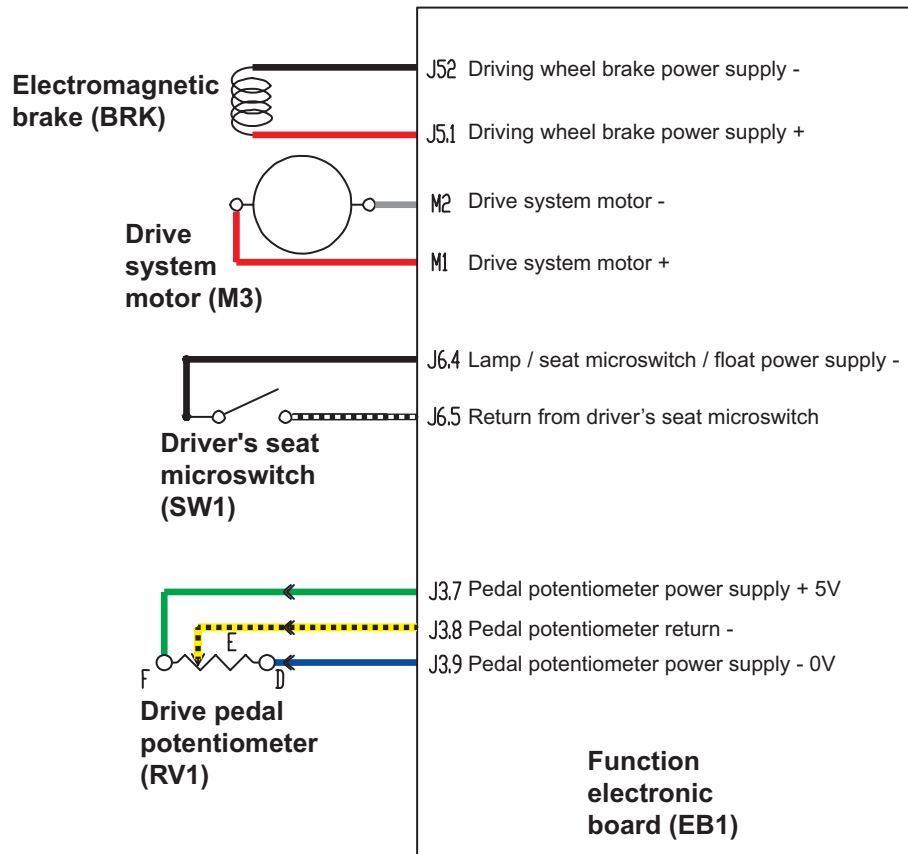

Component Location

- Accelerator pedal (RV1)
- Reverse switch
- Speed adjustment switchers
- Speed indicator LEDS
- Anti-skid control LED
- Driving wheel assembly
- Drive system motor (M3)
- Electromagnetic brake (BRK)
- Driver's seat sensor (SW1)

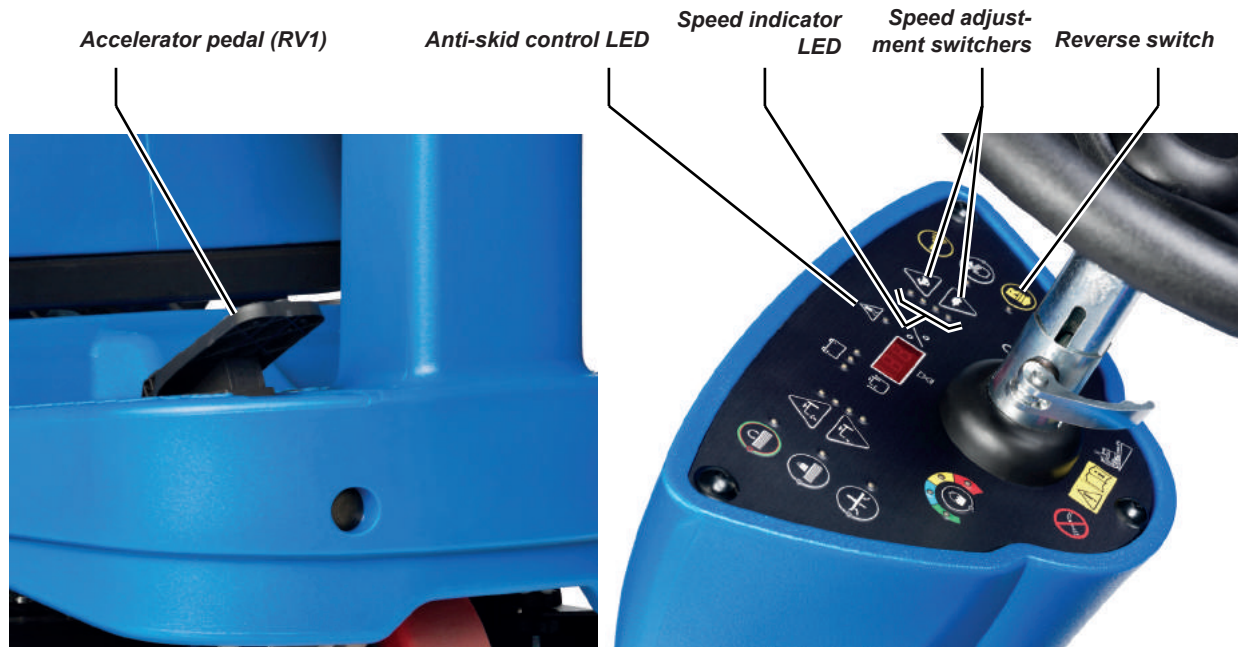

P100759

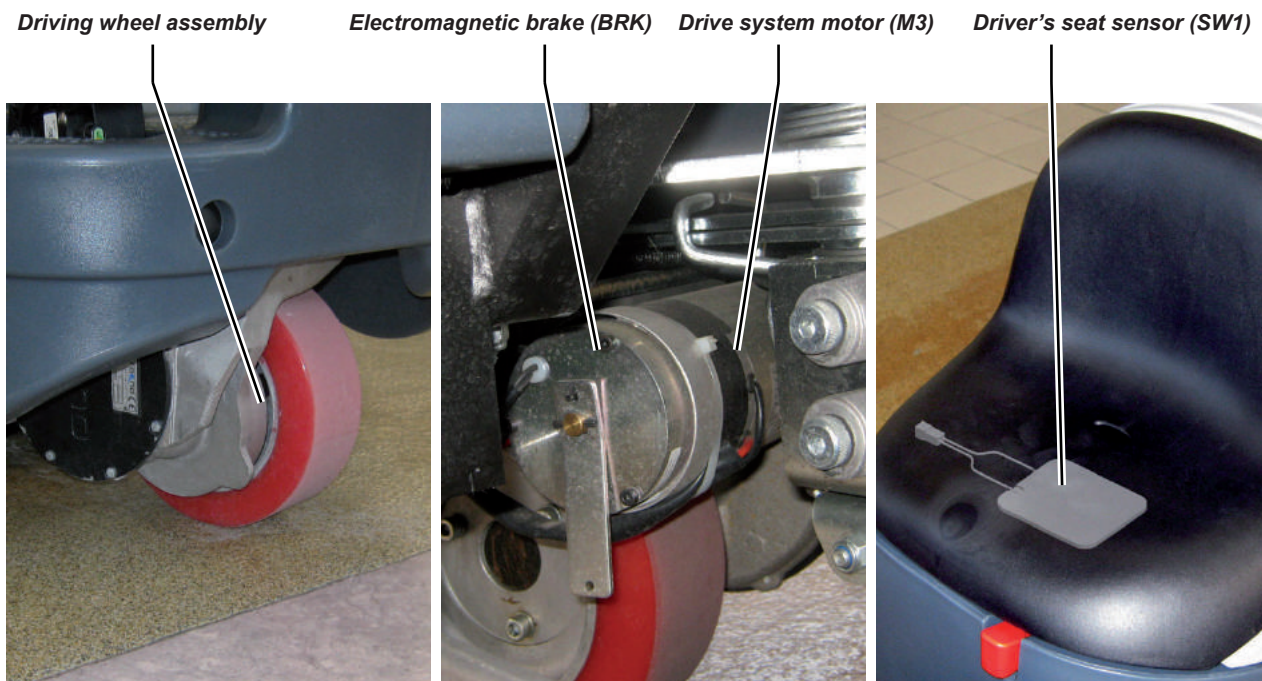

P100760

Troubleshooting

Trouble	Possible Causes	Remedy
The machine does not move	The battery voltage is too low	Charge the battery
	The drive pedal potentiometer (RV1) is misadjusted or broken	Replace the pedal
	The function electronic board (EB1) is faulty	Replace
	The wiring harness is damaged	Check all connections inside the electrical component compartment, included those of the function electronic board
	The drive system motor (M3) carbon brushes are worn	Replace
	The drive system motor (M3) is faulty	Replace
	The driver's seat microswitch (SW1) is faulty	Repair/replace
	There is an open in the function electronic board fuse (F2)	Replace
	The function electronic board (EB1) is faulty	See the Electrical System chapter
The brake does not operate	The electromagnetic brake deactivation lever (BRK) is turned to unlock position	Remove the shim
	The electromagnetic brake braking masses (BRK) are not efficient	Replace the electromagnetic brake
The brake does not activate when pressing the forward/reverse gear pedal	There is an open in wiring harness between function electronic board and electromagnetic brake	Check/repair the wiring harness/ electrical connections
	The electromagnetic brake (BRK) is faulty	Replace
	The function electronic board (EB1) is faulty	Replace
The antiskid LED blinks, and speed is reduced also when travelling in a straight line on level ground	Electronic function board (EB1) installed in incorrect position	Install the electronic board with the long side parallel to the ground

Removal and Installation

Front Fairing Disassembly/Assembly

Disassembly

1. Drive the machine on a level floor with the recovery tank empty.
2. Turn the ignition key to “0” and disconnect the batteries.
3. Unscrew the steering wheel height control lever (A).
4. Remove the steering wheel assembly (B), disconnect the wiring harness connection.
5. Remove the cover (C), then remove the Seeger ring (D).
6. Remove the caps, the screws (E) and the steering wheel plate (F).
7. Disconnect the ignition switch wiring harness.

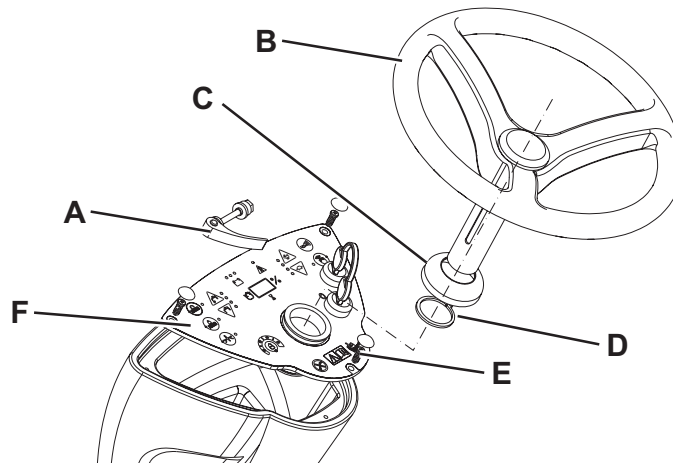

P100757

Front Fairing Disassembly/Assembly (continued)

8. Remove the screws (G), recover the washers, disconnect the wiring harness and then remove the drive pedal (H).
9. Remove the caps, the screws (I) on the machine front and recover the washers.
10. Remove the caps, the screws (J) on the machine foot board and recover the washers and the nuts.
11. Carefully remove the front fairing (K).

Assembly

12. Assemble the components in the reverse order of disassembly.

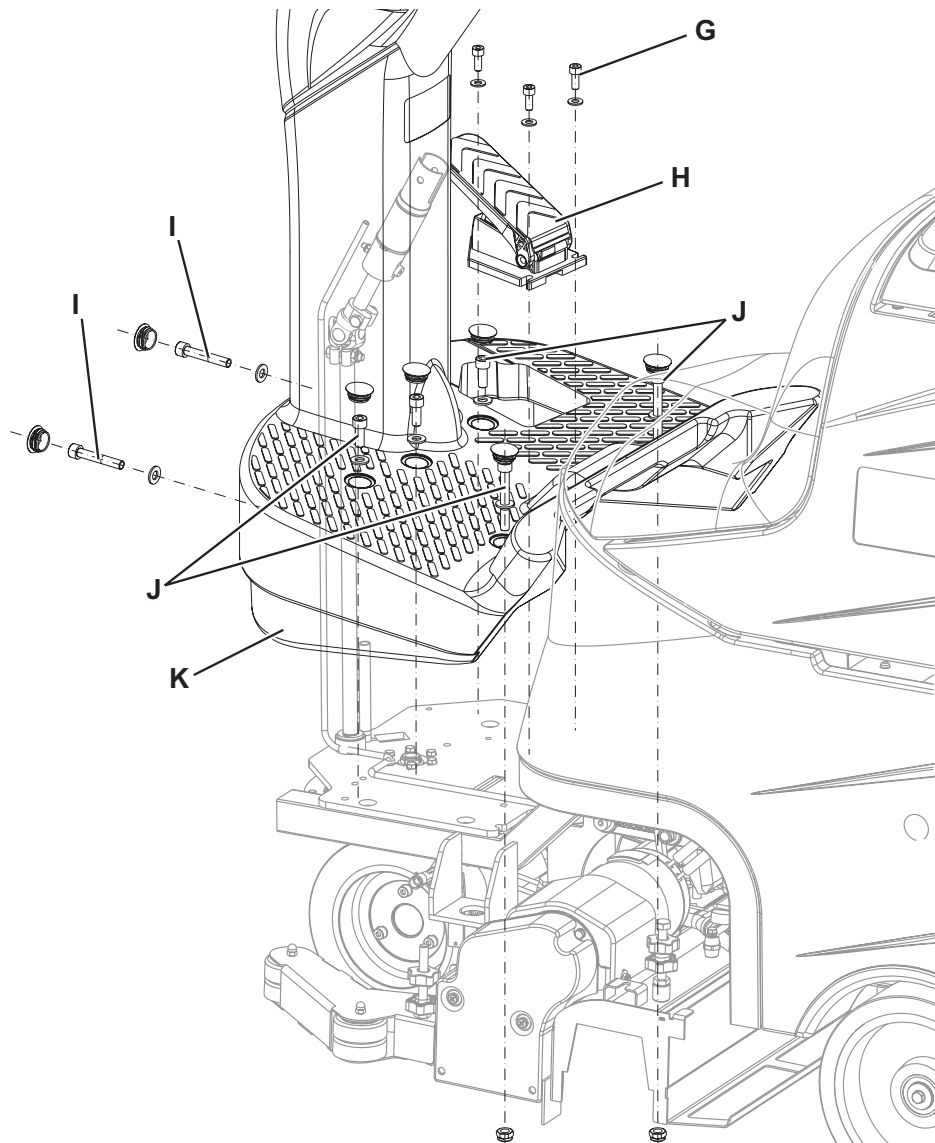

Drive system motor electrical input check



Warning! *This procedure must be performed by qualified personnel only and with the help of an assistant.*

1. Drive the machine on a level floor.
2. Apply proper wedges to rear wheels, so that the machine cannot move when the front wheel is lifted.
3. Slightly lift the front part of the machine and apply to the frame brackets two proper wooden shims high enough to keep the front wheel lifted for about 2 cm from the floor.



Warning! *Pay attention to the rotation of the driving wheel when performing the following steps.*

4. Use a jumper wire to disable the driver's seat microswitch.
5. Apply the amp clamp pliers on the positive cable (red) of the battery wiring harness.
6. Turn the ignition key to "I".
7. Drive the machine at the maximum forward speed by pressing the pedal and check that the electrical input is 5 - 7 A at 24 V. Release the pedal. Turn the ignition key to "0" and remove the amp clamp pliers.
8. If the electrical input is higher, perform the following procedures to detect and correct the abnormal input:
 - Check if there is dust or debris preventing the wheel rotation.
 - If necessary, check if the electromagnetic brake slows down the wheel when the drive system motor is operating (remove the electromagnetic brake and repeat the electrical input check (see the procedure in the relevant paragraph)).
 - If necessary, check the motor carbon brushes (see the procedure in the relevant paragraph).
 - If necessary, disassemble the motor (see the procedure in the relevant paragraph), and check the condition of all its components.
9. If the above-mentioned procedures do not lead to a correct electrical input, the motor must be replaced (see the procedure in the relevant paragraph).

Drive system motor carbon brush check/replacement

Check and replacement

1. Drive the machine on a level floor.
2. Turn the ignition key to “0” and disconnect the batteries.
3. Remove the electromagnetic brake (see the procedure in the relevant paragraph).
4. Remove the drive system motor (see the procedure in the relevant paragraph).
5. At the workbench, with indelible pen (A) mark the installation position of the flange on the drive system motor.
6. Remove the screws (B), the flange (C) and the plastic ring (D).
7. Disengage the spring (E) and remove the 2 carbon brushes (F).
8. Check the carbon brushes for wear.
9. The carbon brushes are worn when the contact with the motor armature is insufficient, the contact surface is not even, the thrust spring is broken, etc.
10. If necessary, replace the carbon brushes.

Reset

11. Assemble the components in the reverse order of disassembly, and note the following:
 - Clean with compressed air the area around the carbon brushes and the removed components.
 - Assemble the carbon brushes (F) with the cables (G) positioned as shown in the figure.
 - Install the flange (C) on the drive system motor using the mark (A) as reference.

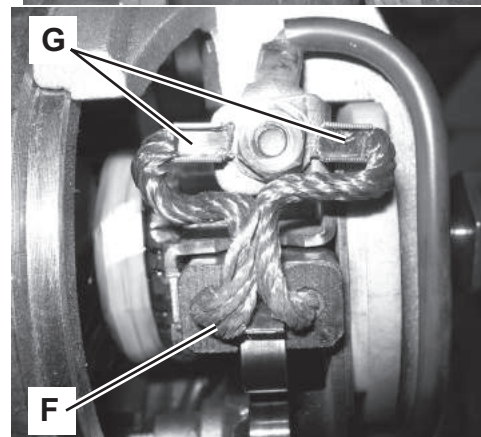
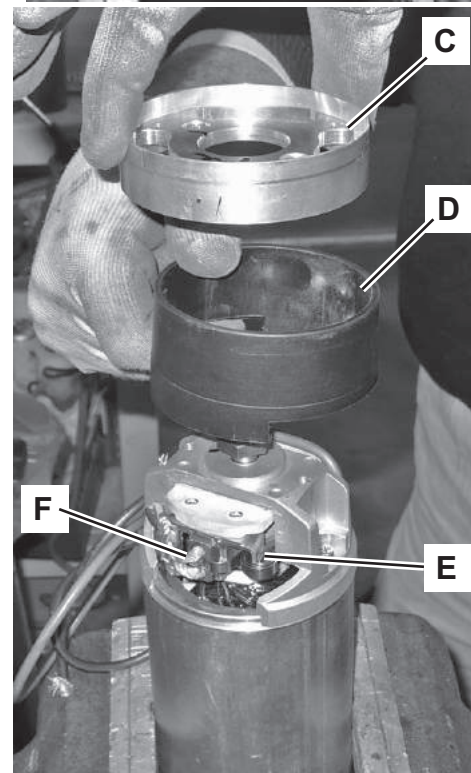
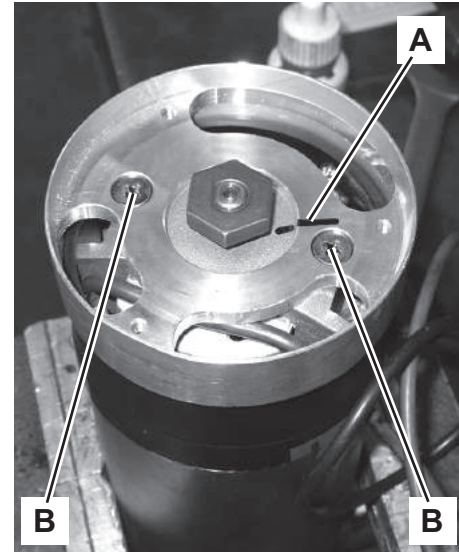

Drive System Motor Disassembly/Assembly

Disassembly

1. Drive the machine on a level floor.
2. Turn the ignition key to “0” and disconnect the batteries.
3. Under the driving wheel assembly, disconnect the drive system motor and electromagnetic brake connections (A).
4. Remove the electromagnetic brake (see the procedure in the relevant paragraph).
5. Remove the driving wheel assembly (see the procedure in the relevant paragraph).
6. At the workbench, with indelible pen (B) mark the installation position of the motor on the gear box.
7. Remove the screws (C) and carefully remove the drive system motor (D).
8. Check the oil seal gasket (E) for wear. In case of oil leaks between the drive system motor and the gear box, replace the oil seal according to the following procedure.

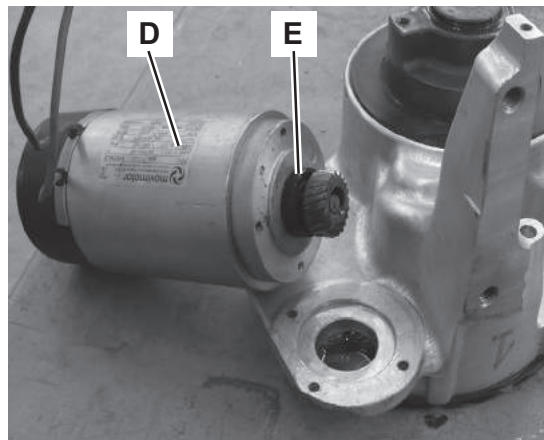
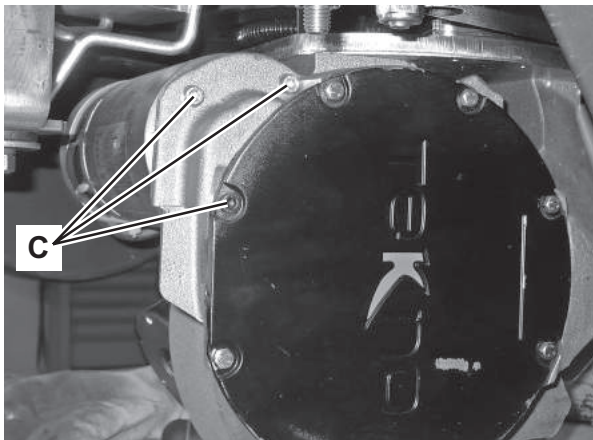
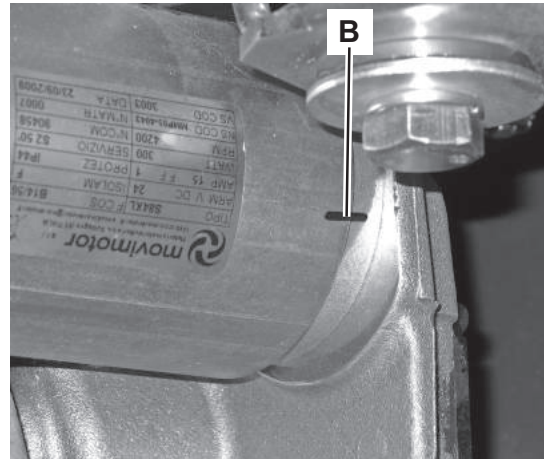
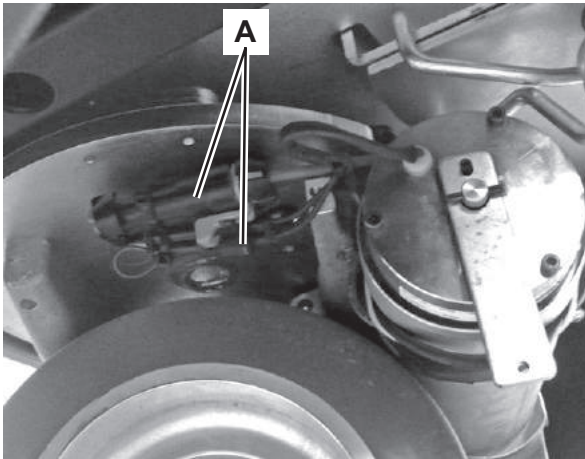

Drive System Motor Disassembly/Assembly (continued)

Oil seal replacement

9. Remove the screw (F) and recover the washer.
10. Carefully remove the gear (G) from the motor pin (I).
11. Remove and replace the oil seal gasket (H).
12. Rub the pin (I) of the drive system motor with sand paper Ø 400. Clean the pin with thinner.
13. Apply Loctite 542 on the pin (I) and on the gear (G), then install.
14. Apply strong threadlock on the threads of the screw (F), then tighten the screw at 10 Nm.

Assembly

15. Assemble the components in the reverse order of disassembly, and note the following:
 - Check the oil level in the hole (J) of the gear box. If necessary, top up with SAE 80W/90 oil.
 - Install the drive system motor on the gear box motor using the mark (B) as reference.

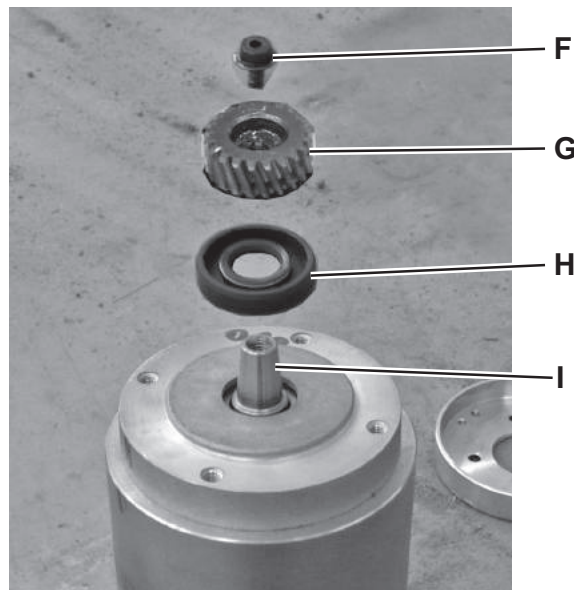
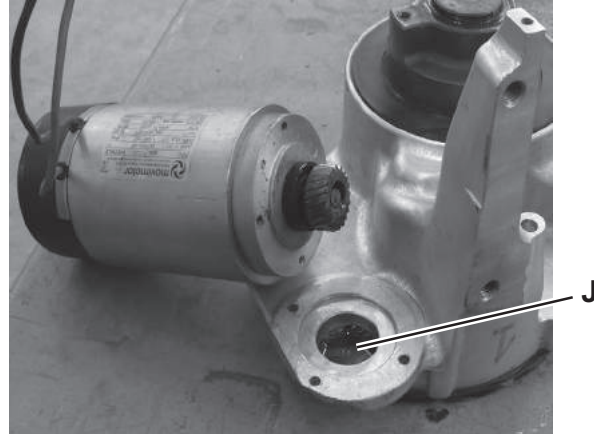
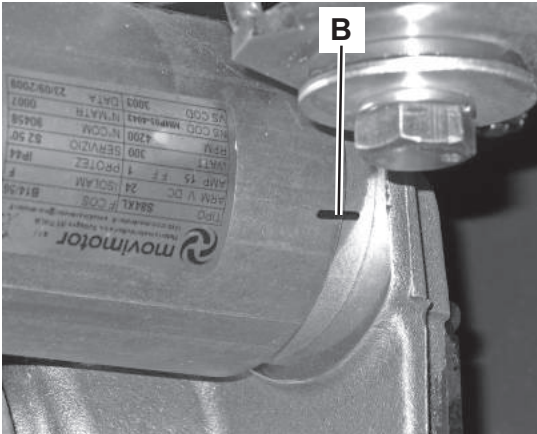

Driving wheel unit disassembly/assembly

Warning! This procedure must be performed by qualified personnel only and with the help of an assistant.

1. Drive the machine on a level floor.
2. Turn the ignition key to “0” and disconnect the batteries.
3. Remove the machine front fairing (see the procedure in the relevant paragraph).
4. Apply proper wedges to rear wheels, so that the machine cannot move when the front side is lifted.
5. Lift the front part of the machine and apply to the frame front sides two proper wooden shims high enough to keep the front wheel lifted for about 10 cm from the floor.
6. Under the driving wheel assembly, disconnect the drive system motor and electromagnetic brake connections.
7. Remove the screws (A) and recover the washers.
8. Carefully lower the driving wheel assembly with steering, paying attention to the wiring harness (B).
9. Remove the screws (C), then remove (only for machines with disc brushes deck) the main gear (D) and the wiring harness shield (E). Note the wiring harness routing under the shield (E), for proper reassembly.
10. Remove the screws (F) and remove the driving wheel (G).
11. Remove the screws (H), recover the washers and remove the wheel (H).

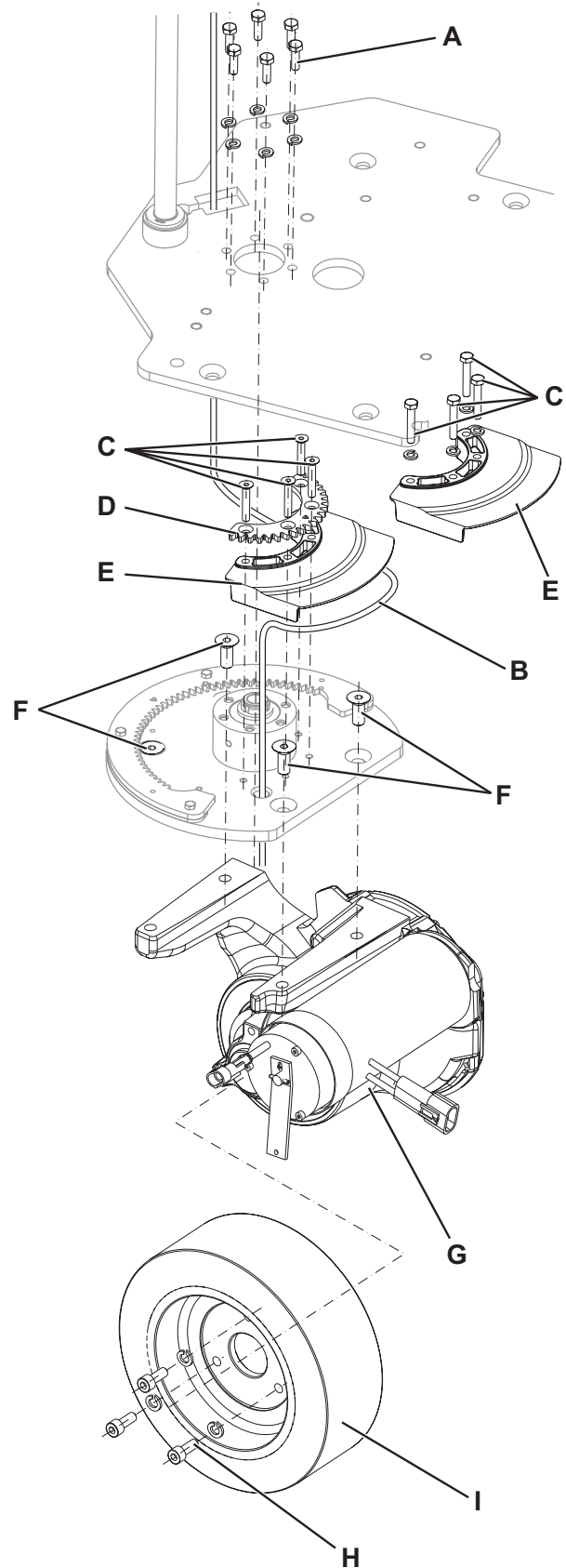

Driving wheel unit disassembly/assembly (continued)

Assembly

12. Assemble the components in the reverse order of disassembly, and note the following:
 - Tighten the screws (H) at 16 Nm.
 - (Only for machines with disc brushes deck): when installing the driving wheel assembly, the gears must be coupled with the straight wheel and the arrows (J) aligned as shown in the figure.
 - Tighten the screws (F, C and A) at 22 Nm.

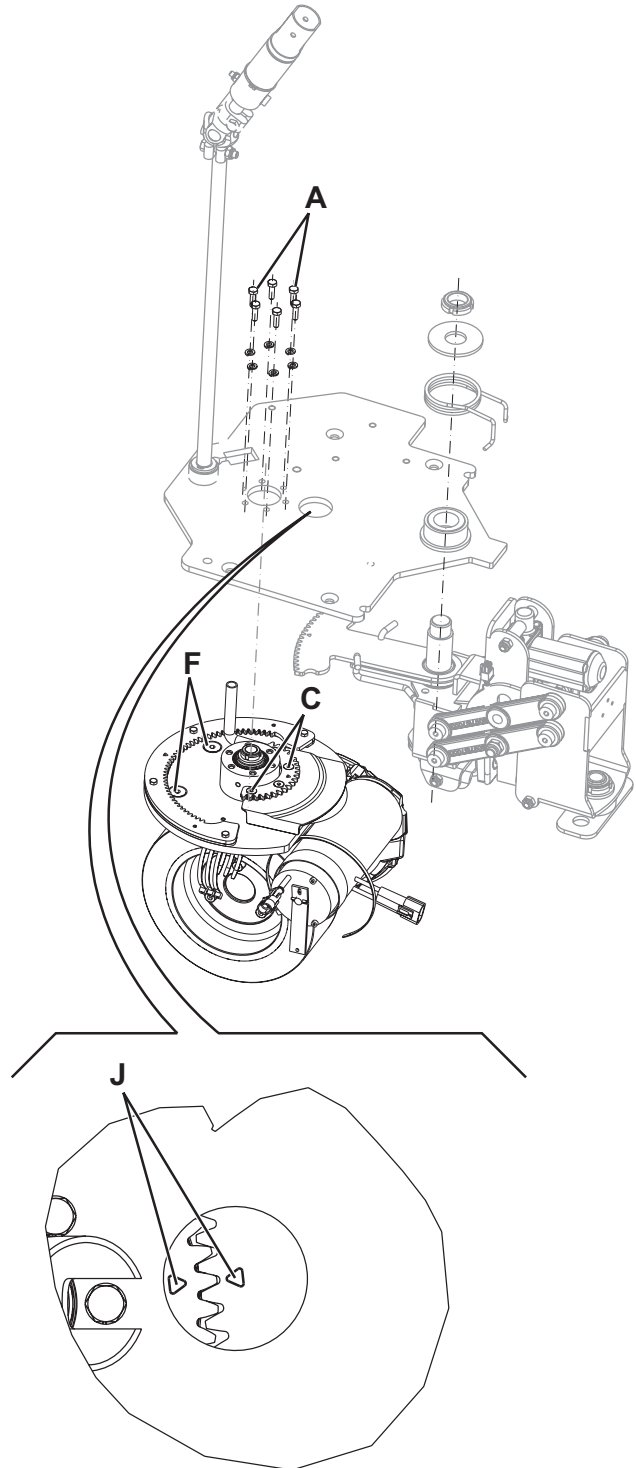

Driver's Seat Safety Microswitch Replacement

Disassembly

1. Drive the machine on a level floor.
2. Turn the ignition key to "0" and disconnect the batteries.
3. Lift the recovery tank assembly and remove the driver's seat mounting screws.
4. Disconnect the microswitch connector.
5. Lift the recovery tank cover and remove the remaining driver's seat mounting screws.
6. Remove the driver's seat, remove the wiring harness from the hole and then remove the driver's seat microswitch by peeling off the adhesive.

Assembly

7. Assemble the components in the reverse order of disassembly.
8. Check that the machine cannot be started when the operator is not on the driver's seat (17).

Electromagnetic Brake Disassembly/Assembly

Disassembly

1. Place the machine on a hoisting system (if available), then lift it. Otherwise, drive the machine on a level floor.
2. Lower the brush deck.
3. Turn the ignition key to “0” and disconnect the batteries.
4. Turn the steering wheel to reach the electromagnetic brake.
5. On the left side of the machine, remove the screws (A) and disconnect the connector (B).
6. Remove the electromagnetic brake (C).

Assembly

7. Assemble the components in the reverse order of disassembly, and note the following:
 - Before installing the electromagnetic brake (C) clean it with compressed air.
 - Install the electromagnetic brake with the lever (D) downwards.
8. After installing the electromagnetic brake check the parking brake.

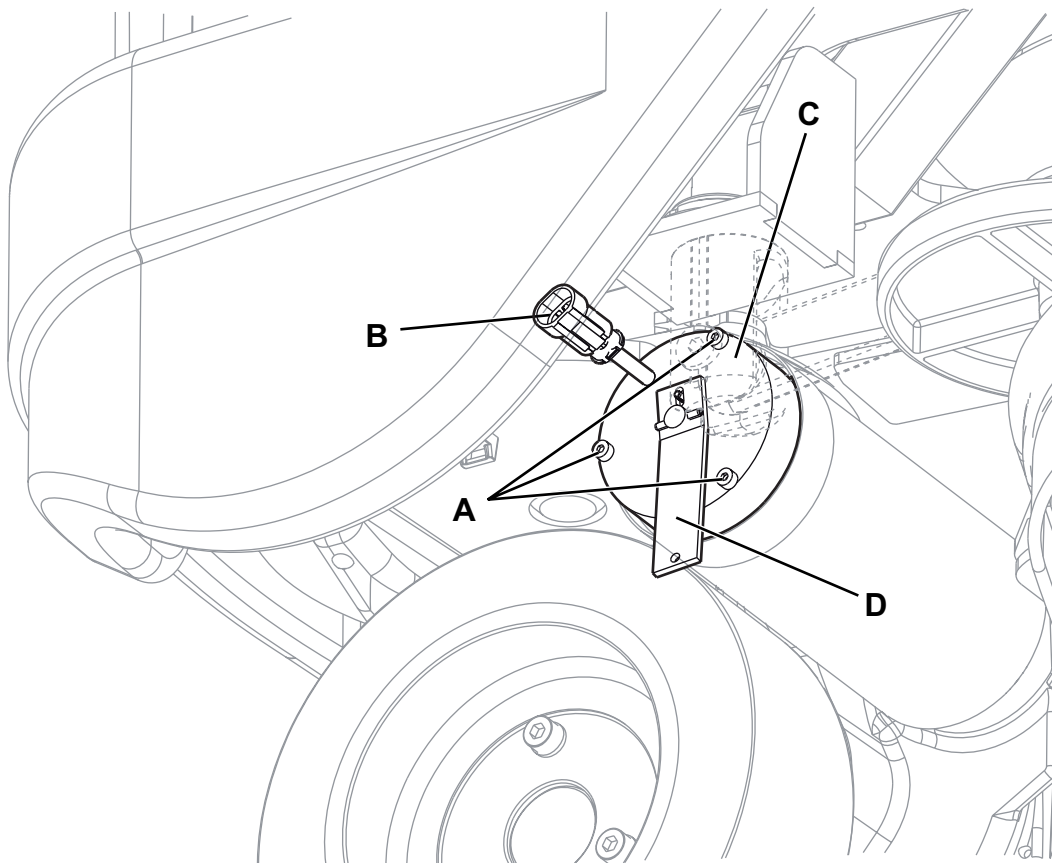

Specifications

Description		SCRUBTEC R 466 - FOCUS II Micro Rider 26D	SCRUBTEC R 471	SCRUBTEC R 471C	SCRUBTEC BOOST® R4 - FOCUS II Micro Rider 28 BOOST
Rear wheel diameter		9.8 in (250 mm)			
Rear wheel specific pressure on the floor (*)		130 psi (0.9 N/mm ²)			
Front steering, driving and braking wheel diameter		8.8 in (225 mm)			
Front wheel specific pressure on the floor (*)		72 psi (0.5 N/mm ²)			
Driving wheel technical data	Max torque	100 Nm			
	Continuous torque	30 Nm			
	Load on the wheel	150 daN			
	Ratio	1/28.25			
Drive system motor technical data	Power	0.4 hp (300 W)			
	Voltage	24 V			
	Speed	4200 rpm			
	Electrical input	15 A			
	Protection class	IP44			
Electromagnetic brake technical data	Strength	4.0 Nm			
	Voltage	24 V			
Maximum speed		3.7 mi/h (6 km/h)			
Maximum gradient when working		2% (1.14°)			

(*) Machines have been tested under the following conditions:

- With operator on board (165.3 lb - 75 kg)
- Maximum battery size
- Maximum brush and squeegee size
- Full clean water tank
- Optional components installed
- Weight on wheels checked
- Print on the floor checked on cement for each single wheel
- Result expressed as maximum value for front and rear wheels