



PACIFIC[®]
F L O O R C A R E

PURPOSE BUILT.[®]

S-24 / S-28 / S-32

22 GALLON MID-SIZE AUTOSCRUBBER PARTS & OPERATING MANUAL



Thank you for purchasing a Pacific Floorcare product. Carefully inspect all components for freight damage. If such damage is discovered, file a “CONCEALED DAMAGE REPORT” immediately with the delivering carrier.

Read this manual carefully and keep it near the machine, protected from liquids and other damaging substances. Failure to follow the instructions may result in injury or damage to equipment and property.

The contents of this manual are based on the latest product information available at the time of publication. Pacific Floorcare reserves the right to make changes or improvements without being obliged to apply changes to the machines previously sold.

New manuals can be downloaded from: www.pacificfloorcare.com/manuals

22 GALLON AUTOSCRUBBER SPECIFICATIONS

Features	Specifications	
Model:	S-24 (Disk)	S-28 (Orbital)
Solution Delivery System		
Solution capacity:	22 gal / 83 l	22 gal / 83 l
Solution control: (Standard)	0-.55 gpm / 0-2.1 lpm, Variable knob adjustment	0-.55 gpm / 0-2.1 lpm, Variable knob adjustment
Solution control: (w/ Chemical Injection)	Low, Med & High flow settings (.10, .25 & .45 gpm / .38, .95 & 1.7 lpm) Speed Sensitive Flow or Constant Output Flow Control	Low, Med & High flow settings (.10, .25 & .45 gpm / .38, .95 & 1.7 lpm) Speed Sensitive Flow or Constant Output Flow Control
Scrubbing System		
Cleaning path:	24 in / 610 mm	28 in / 711 mm
Pad/brush size:	(2) 12 in / 305 mm	(1) 28 x 14 in / 711 x 356 mm
Productivity (per hour)- Theoretical max:	26,400 ft	30,800 ft
Productivity (per hour)-Average coverage rate:*	19,525 ft	22,425 ft
Brush Drive System		
Brush motor horsepower (each):	(1) 1 hp / 750 W	(1) 1 hp / 750 W
Brush rpm:	360 rpm	2,200 rpm
Brush/pad pressure:	50, 100 & 140 lb / 23, 45 & 64 kg	70, 110 & 160 lb / 32, 50 & 73 kg
Brush/pad attachment/removal:	Automatic on/off	Manual
Recovery System		
Recovery tank accessibility:	Full clean out access	Full clean out access
Recovery tank capacity:	25 gal / 95 l (3 gal / 11.4 l demisting chamber)	25 gal / 95 l (3 gal / 11.4 l demisting chamber)
Vacuum motor:	.7 hp / 522 W, 3-stage	.7 hp / 522 W, 3-stage
Vac motor cfm / cmm:	71 cfm / 2.0 cmm	71 cfm / 2.0 cmm
Vac motor water-lift:	71 in / 180 cm	71 in / 180 cm
Standard / Narrow Aisle Squeegee width:	35 / 30 in (89 / 76 cm)	40 / 35 in (102 / 89 cm)
Drive System		
Drive Type:	Transaxle Drive	Transaxle Drive
Motor horsepower:	.5 hp / 373 W	.5 hp / 373 W
Battery System		
System voltage:	24 V	24 V
Battery amp hour rating:	(4) 6V: 260 AH (wet) / 250 AH (MF)	(4) 6V: 260 AH (wet) / 250 AH (MF)
Battery run time:	Up to 5.5 hours	Up to 5.5 hours
Charger description:	On-board (standard) Off-board (optional)	On-board (standard) Off-board (optional)
Machine specifications		
Product length:	54 in / 137 cm	52 in / 132 cm
Product width (without squeegee):	26 in / 66 cm	28 in / 71 cm
Product height:	44 in / 112 cm	44 in / 112 cm
Product weight (with batteries):	650 lb / 295 kg	665 lb / 302 kg
Sound level (operator's ear):	65 dBA	63 dBA
Construction:	Rotationally molded polyethylene tanks, powder coated steel frame	Rotationally molded polyethylene tanks, powder coated steel frame
*Productivity calculations utilize key factors from ISSA 540 cleaning times handbook		
Note: Specifications subject to change without notice		

22 GALLON AUTOSCRUBBER SPECIFICATIONS

Features	Specifications	
Model:	S-28 (Disk)	S-32 (Disk)
Solution Delivery System		
Solution capacity:	22 gal / 83 l	22 gal / 83 l
Solution control: (Standard)	0-.55 gpm / 0-2.1 lpm, Variable knob adjustment	0-.55 gpm / 0-2.1 lpm, Variable knob adjustment
Solution control: (w/ Chemical Injection)	Low, Med & High flow settings (.10, .25 & .45 gpm / .38, .95 & 1.7 lpm) Speed Sensitive Flow or Constant Output Flow Control	Low, Med & High flow settings (.10, .25 & .45 gpm / .38, .95 & 1.7 lpm) Speed Sensitive Flow or Constant Output Flow Control
Scrubbing System		
Cleaning path:	28 in / 711 mm	32 in / 813 mm
Pad/brush size:	(2) 14 in / 356 mm Disks	(2) 16 in / 406 mm Disks
Productivity (per hour)-Theoretical max:	30,800 ft	35,200 ft
Productivity (per hour)-Average coverage rate:*	22,425 ft	25,125 ft
Brush Drive System		
Brush motor horsepower (each):	(2) 1 hp / 750 W	(2) 1 hp / 750 W
Brush rpm:	300 rpm	300 rpm
Brush/pad pressure:	70, 110 & 150 lb / 32, 50 & 68 kg	70, 110 & 150 lb / 32, 50 & 68 kg
Brush/pad attachment/removal:	Automatic on/off	Automatic on/off
Recovery System		
Recovery tank accessibility:	Full clean out access	Full clean out access
Recovery tank capacity:	25 gal / 95 l (3 gal / 11.4 l demisting chamber)	25 gal / 95 l (3 gal / 11.4 l demisting chamber)
Vacuum motor:	.7 hp / 522 W, 3-stage	.7 hp / 522 W, 3-stage
Vac motor cfm / cmm:	71 cfm / 2.0 cmm	71 cfm / 2.0 cmm
Vac motor water-lift:	71 in / 180 cm	71 in / 180 cm
Standard / Narrow Aisle Squeegee width:	40 / 35 in (102 / 89 cm)	44.5 / 40 in (113 / 102 cm)
Drive System		
Drive Type:	Transaxle Drive	Transaxle Drive
Motor horsepower:	.5 hp / 373 W	.5 hp / 373 W
Battery System		
System voltage:	24 V	24 V
Battery amp hour rating:	(4) 6V: 260 AH (wet) / 250 AH (MF)	(4) 6V: 260 AH (wet) / 250 AH (MF)
Battery run time:	Up to 4.5 hours	Up to 4.0 hours
Charger description:	On-board (standard) Off-board (optional)	On-board (standard) Off-board (optional)
Machine specifications		
Product length:	56 in / 142 cm	58 in / 147 cm
Product width (without squeegee):	30 in / 76 cm	34 in / 86 cm
Product height:	44 in / 112 cm	44 in / 112 cm
Product weight (with batteries):	660 lb / 299 kg	665 lb / 302 kg
Sound level (operator's ear):	65 dBA	65 dBA
Construction:	Rotationally molded polyethylene tanks, powder coated steel frame	Rotationally molded polyethylene tanks, powder coated steel frame
*Productivity calculations utilize key factors from ISSA 540 cleaning times handbook		
Note: Specifications subject to change without notice		

TABLE OF CONTENTS

SAFETY INFORMATION	1
UNPACKING THE MACHINE	2
TRANSPORTING THE MACHINE	3
BATTERIES	4
SELECTION	4
INSTALLATION	4
SERVICING LEAD ACID BATTERIES (NON-HYDROLINK® MODELS).....	5
SERVICING LEAD ACID BATTERIES WITH HYDROLINK®	6
WATERING SYSTEM	6
BATTERYSHIELD® AUTOMATED WET BATTERY PROTECTION SYSTEM.....	7
CHARGING	9
ON-BOARD CHARGER	9
OFF-BOARD CHARGER	11
PRE-USE SETUP	12
ORBITAL PADS & CHEMICAL-FREE FINISH REMOVAL (CFR).....	16
DISK MACHINE PAD DRIVERS & BRUSHES	17
SQUEEGEE SYSTEM	19
RECOMMENDED MAINTENANCE	22
RECOMMENDED SERVICE PARTS	23
TROUBLESHOOTING GUIDE	26
PARTS DIAGRAMS	28
BATTERIES, BATTERYSHIELD® & HYDROLINK®	28
OPTIONAL ONBOARD CHARGER	29
CONTROLS.....	30
ELECTRONICS.....	37
FRAME ASSEMBLY	41
HEAD LIFT ASSEMBLY	42
SOLUTION TANK	43
RECOVERY TANK AND VACUUM	44
OPTIONAL CHEMICAL INJECTION.....	46
35” SQUEEGEE ASSEMBLY.....	47
40” SQUEEGEE ASSEMBLY.....	48
45” SQUEEGEE ASSEMBLY.....	49
SQUEEGEE LINK.....	50
SCRUB HEADS	52
WIRING DIAGRAMS	64
S-24 WIRING DIAGRAM	64
S-28 (DISK) & S-32 WIRING DIAGRAM.....	66
S-28 ORBITAL WIRING DIAGRAM	68
BATTERYSHIELD® (OPTIONAL) WIRING DIAGRAM	70
OPTIONAL CHEMICAL INJECTION WIRING DIAGRAM.....	71

SAFETY INFORMATION

This machine is intended for commercial use. Only use recommended pads or brushes and commercially approved floor cleaning chemicals intended for machine application.

WARNING: A potentially hazardous situation that, if not avoided, could result in death or serious injury.

CAUTION: A potentially hazardous situation that, if not avoided, could result in moderate injury or serious property damage.

NOTE: Information that will prevent premature equipment failure or minor property damage.

WARNING: This product can expose you to chemicals including lead and lead compounds which are known to the State of California to cause cancer and birth defects or other reproductive harm. For more information go to www.P65Warnings.ca.gov.

WARNING: This machine is not equipped with explosion proof motors. Never use near flammable or reactive materials, liquids, vapors or combustible dusts. Electric motors spark internally during operation and could cause a flash fire or explosion.

WARNING: Batteries emit hydrogen and oxygen gas.
- Keep sparks and open flame away. Do not smoke near the machine
- Charge batteries in a well-ventilated area with the battery compartment open

WARNING: Do not plug in charger cable if wall cord or battery harness is damaged.

WARNING: Disconnect battery cables before servicing.

WARNING: Do not wear jewelry when working near moving or electrical components.

WARNING: Do not use the machine as a means for transport.

WARNING: Never allow children to play on or around machine.

WARNING: Do not bump into shelves or scaffoldings, especially where there is a risk of falling objects.

WARNING: Support the machine on safety stands before working underneath.

CAUTION: Keep hands away from spinning brushes.

CAUTION: Do not operate machine unless trained and authorized.

CAUTION: Do not modify the machine from its original design.

CAUTION: Do not operate machine if it is not in proper operating condition.

CAUTION: Wear non-slip shoes when operating machine.

CAUTION: Reduce speed when turning or operating on inclines and slippery surfaces.

CAUTION: Use Bromine only in your tank treatment system! Do not use chlorine. Chlorine can interact with ammonia-based detergents and cause harmful fumes.

CAUTION: Follow mixing and handling instructions on chemical containers.

CAUTION: Remove the batteries and get assistance before lifting the machine manually.

CAUTION: Park and service the machine on a level surface and remove the key.

CAUTION: Always wear protective clothing, gloves and goggles when handling and charging batteries.

CAUTION: Avoid moving parts and do not wear loose jackets, shirts or sleeves when servicing.

NOTE: Do not power spray or hose off the machine. Electrical malfunction may occur.

NOTE: All repairs must be performed by a qualified service technician using approved replacement parts.

NOTE: To avoid damaging the floor, do not allow the brush/pad to operate while the machine is stationary.

NOTE: Use a ramp with no more than a 12° incline when loading or unloading the machine.

NOTE: Use tie down straps to secure the machine to the truck or trailer during transport.

NOTE: Turn power off and put the scrub head in the lowered position during transport.

NOTE: Discontinue use and report machine damage or faulty operation immediately.

NOTE: Store the machine indoors where the temperature is between 32° and 104°F (0° and 40°C).

NOTE: Do not lower the orbital head without a pad. Doing so damages the Mighty-Lok® face.

NOTE: Failure to clean the HydroLink® light pipe will limit BatteryShield's® ability to read the water level and will reduce battery life.

NOTE: Do not use an extension cord. This will void the warranty on the charger.

NOTE: Batteries designed for automotive or marine and RV use are not suited for use in floor scrubbers.

NOTE: Ensure battery charging and storage locations comply with OSHA and any governing agencies' standards based on your particular location and application.

UNPACKING THE MACHINE

NOTE: Use a ramp with no more than a 12° incline when loading or unloading the machine.

1. Remove the outer packaging
2. Remove the four cleats and two tie down brackets holding the machine to the pallet
3. Raise the scrub head into the transport position.
4. Use a suitable ramp or platform and carefully pull the machine backwards down from the pallet.

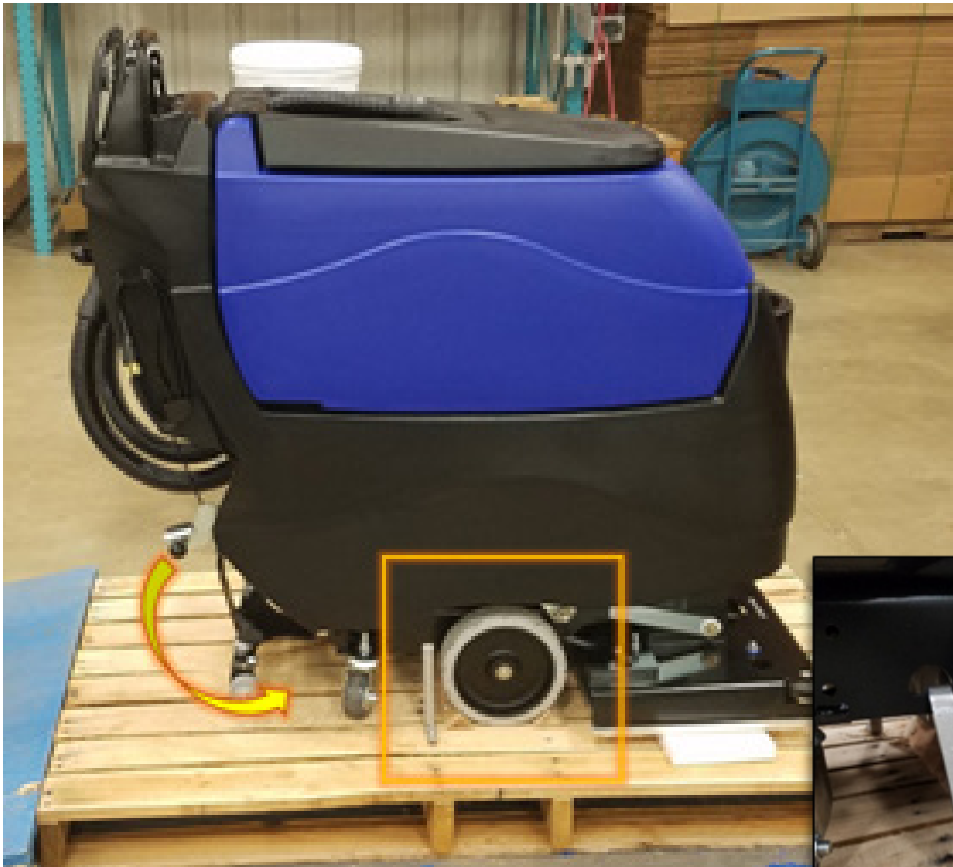

TRANSPORTING THE MACHINE

CAUTION: Remove the batteries and get assistance before lifting the machine manually.

NOTE: Use a ramp with no more than a 12° incline when loading or unloading the machine.

NOTE: Turn power off and put the scrub head in the lowered position during transport.

NOTE: Do not rest the orbital head on a hard surface without a pad. Doing so damages the Mighty-Lok® face.

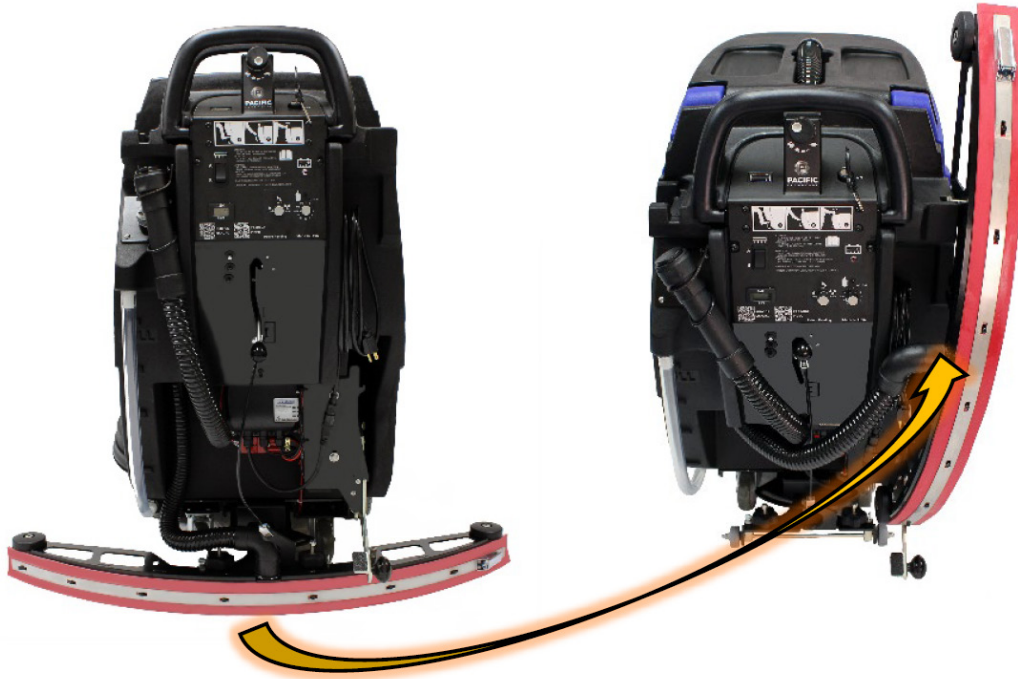

TIE DOWN PROCEDURE

The S-Series Scrubber was designed for easy transport on a route cleaning program. Two options are available for tying the machine down to a truck or trailer during transport.

Tie down holes are located on both sides of the main frame



Run tie down straps between the recovery tank and solution tank



BATTERIES



WARNING: Battery posts, terminals, and related accessories contain lead and lead compounds, chemicals known to the State of California to cause cancer and reproductive harm, and during charging, strong inorganic acid mists containing sulfuric acid are involved, a chemical known to the State of California to cause cancer. Wash hands after handling. For more information go to www.P65Warnings.ca.gov.

WARNING: Batteries emit hydrogen and oxygen gas.
-Keep sparks and open flame away. Do not smoke near the machine.
-Charge batteries in a well-ventilated area with the battery compartment open.

WARNING: Do not wear jewelry when working near moving or electrical components.

CAUTION: Remove the batteries and get assistance before lifting the machine manually.

CAUTION: Park and service the machine on a level surface and remove the key.

CAUTION: Always wear protective clothing, gloves and goggles when handling and charging batteries.

NOTE: All repairs must be performed by a qualified service technician using approved replacement parts.

NOTE: Batteries designed for automotive or marine and RV use are not suited for use in floor scrubbers.

SELECTION

The machine requires four 6 VDC Lead Acid or AGM Deep Cycle batteries designed for floor scrubber use with the following maximum dimensions:

- Width: 7 1/8 in (181 mm)
- Length: 12 15/16 in (264 mm)
- Height: 10 5/8 in (295 mm)

INSTALLATION

1. Open the recovery tank.
2. Use a lifting device capable of transferring the batteries safely.
3. Slide the batteries forward.
4. Connect the batteries in a series to obtain an overall voltage of 24V on the lugs.
5. Fully charge the batteries before using the machine.

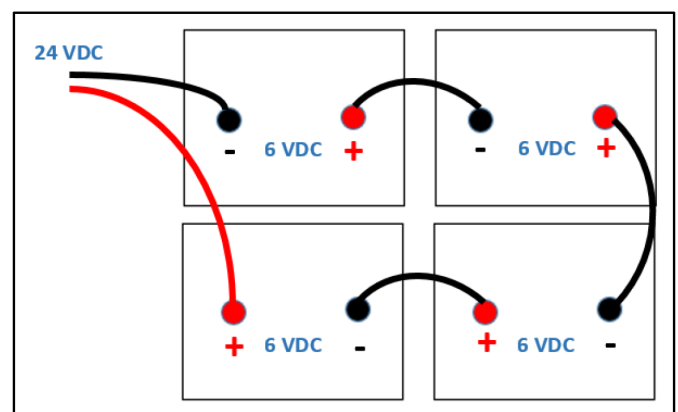

SERVICING LEAD ACID BATTERIES (NON-HYDROLINK® MODELS)

WARNING: Battery posts, terminals, and related accessories contain lead and lead compounds, chemicals known to the State of California to cause cancer and reproductive harm, and during charging, strong inorganic acid mists containing sulfuric acid are involved, a chemical known to the State of California to cause cancer. Wash hands after handling. For more information go to www.P65Warnings.ca.gov.



WARNING: Batteries emit hydrogen and oxygen gas.
-Keep sparks and open flame away. Do not smoke near the machine.
-Charge batteries in a well-ventilated area with the battery compartment open.



WARNING: Do not wear jewelry when working near moving or electrical components.

CAUTION: Always wear protective clothing, gloves and goggles when handling and charging batteries.

REQUIRED EQUIPMENT

- Eye protection
- Acid resistant gloves
- Distilled water
- Baking soda (neutralizes acid spills)

SAFETY

NEVER:

- Add acid to a battery.
- Smoke near batteries.
- Charge a frozen battery.
- Leave an acid spill unattended.
- Store batteries unless they are fully charged.
- Charge a battery when the temperature is above 122°F (50°C).
- Charge a flooded battery without securing vent caps on the cells.
- Place objects on top of batteries, which can cause a short circuit.

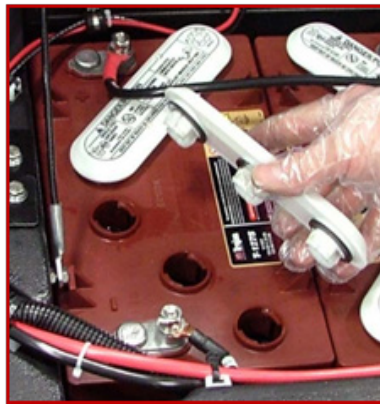

Remove the caps and place them upside down to inspect

ALWAYS:

- Neutralize acid spills with baking soda and water.
- Use insulated tools and check that connections are tight.

WATERING

- If contact with electrolyte (sulfuric acid) occurs, flush with large amounts of water.
- Use only distilled water (tap water can contain contaminants that will damage the battery).
- Remove the caps and place them upside down to check electrolyte levels.
- For discharged or partially charged batteries, add just enough water to cover the plates.
- Fully charge the batteries.
- Add distilled water to a level of 1/8" below the vent well.



CLEANING & INSPECTION

- Fluid on the top of a battery may mean it is being over-watered or overcharged.
- Check cleanliness and keep terminals and connectors free of corrosion.
- Clean with a solution of 1 cup baking soda to 1 gallon of water.
- Do not allow cleaning solution to get inside the battery.
- Rinse with water and dry with a clean cloth.
- Keep the area around batteries clean and dry.
- Properly secure all vent caps.
- Check battery cables and connections. Replace any damaged cables and tighten any loose connections.

SERVICING LEAD ACID BATTERIES WITH HYDROLINK® WATERING SYSTEM

WARNING: Battery posts, terminals, and related accessories contain lead and lead compounds, chemicals known to the State of California to cause cancer and reproductive harm, and during charging, strong inorganic acid mists containing sulfuric acid are involved, a chemical known to the State of California to cause cancer. Wash hands after handling. For more information go to www.P65Warnings.ca.gov.



1. Position the container of distilled water below the level of the top of the batteries to prevent siphoning.
2. Place the end of the watering system hose in the distilled water and squeeze the bulb to fill the system.
3. Remove the dust cover from the Hydrolink® snake connected to the batteries.
4. Connect the coupler on the Hydrolink® snake to the coupler on the watering system using the quick disconnect fittings.
5. While squeezing the hand pump, observe the flow indicator (spinning red balls). As the batteries begin to fill, the spinning of the flow indicator balls will slow. Batteries are full when the flow indicators completely stop spinning.

NOTE: Battery systems may take more than 1/2 gallon of water once the BatteryShield® light has illuminated. Failure to actuate the hand pump until the flow indicator stops spinning will result in batteries being under or unevenly serviced which will reduce battery life.

6. When the flow indicator stops, and not before, immediately disconnect the couplers by depressing the push button on the watering system coupler.

NOTE: Leaving the watering system connected could result in the batteries being over filled. Disconnecting the watering system before the flow indicator stops spinning will result in batteries being under serviced and battery life will be reduced.

7. Replace the dust cover on the Hydrolink® snake.

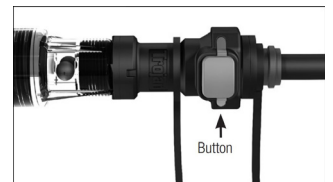
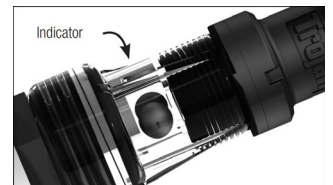
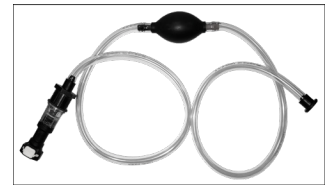

BATTERYSHIELD® AUTOMATED WET BATTERY PROTECTION SYSTEM

Scrubbers equipped with BatteryShield® technology have a sensor on the battery pack and a red LED indicator on the control panel which monitor and communicate low water conditions.

1. When batteries are fully charged and the key is turned on, BatteryShield® will check the water level.
 - If the LED remains off, there is sufficient water in the batteries.
 - A solid red LED means BatteryShield® senses a low-water level. The brush motor will be disabled to prevent battery damage.
 - A blinking red LED means the BatteryShield® light pipe needs to be cleaned (see below).

NOTE: Failure to clean the HydroLink® light pipe will limit the BatteryShield's® ability to read the water level and will reduce battery life.



2. Turn the key off and use the HydroLink® single-point battery watering system to fill the batteries.

NOTE: Battery packs equipped with BatteryShield® may take *more than 1/2 gallon of water* after the BatteryShield® LED has illuminated. **Failure to pump the HydroLink™ bulb until it will no longer compress may result in uneven battery servicing and premature battery failure.**

3. After completing the HydroLink® watering procedure, cycle the key to verify the LED stays off.

CLEANING THE BATTERYSHIELD® SENSOR LIGHT PIPE

WARNING: Battery posts, terminals, and related accessories contain lead and lead compounds, chemicals known to the State of California to cause cancer and reproductive harm, and during charging, strong inorganic acid mists containing sulfuric acid are involved, a chemical known to the State of California to cause cancer. Wash hands after handling. For more information go to www.P65Warnings.ca.gov.



WARNING: Do not wear jewelry when working near moving or electrical components.

WARNING: Batteries emit hydrogen and oxygen gas.
-Keep sparks and open flame away. Do not smoke near the machine.
-Charge batteries in a well-ventilated area with the battery compartment open.

CAUTION: Always wear protective clothing, gloves and goggles when handling and charging batteries.

NOTE: Failure to clean the HydroLink® light pipe will limit the BatteryShield's® ability to read the water level and will reduce battery life.

1. Remove the cap with the black sensor module, being careful not to damage the yellow floats. Do not remove the black module from the cap assembly.
2. Thoroughly wipe the clear light pipe next to the middle yellow float, paying attention to the tip of the pipe.
3. While the cap is still removed, cycle the key and verify the LED stays on steady. Turn the key off.
4. Carefully align the cap and press it firmly onto the battery making sure it is fully seated.
5. Complete the battery servicing procedures above, cycle the key, and verify the light stays off.
6. The machine is ready for use.



CHARGING

WARNING: Battery posts, terminals, and related accessories contain lead and lead compounds, chemicals known to the State of California to cause cancer and reproductive harm, and during charging, strong inorganic acid mists containing sulfuric acid are involved, a chemical known to the State of California to cause cancer. Wash hands after handling. For more information go to www.P65Warnings.ca.gov.



WARNING: Do not plug in charger cable if wall cord or battery harness is damaged.

NOTE: Do not use an extension cord. This will void the warranty on the charger.

NOTE: Ensure battery charging and storage locations comply with OSHA and any governing agencies' standards based on your particular location and application.

ON-BOARD CHARGER

The on-board charger has three LEDs to indicate the status of the charging cycle when it is plugged in:

LED INDICATION	MEANING
GREEN flashing (2 seconds)	Charger is set for AGM batteries
YELLOW flashing (continuous)	Unsuitable battery connected or output short circuit
RED flashing (2 seconds)	Charger is set for Lead Acid batteries
RED flashing (continuous)	Safety timer exceeded or internal short circuit
Solid GREEN	The unit is fully charged
Solid YELLOW	Phase 2 of charging is in progress
Solid RED	Charging cycle has begun

NOTE: Do not use an extension cord. This will void the warranty on the charger.

SETTING THE CHARGER ON MACHINES PURCHASED WITHOUT BATTERIES

Configure the charging profile to the type of batteries installed on the machine. Switch banks SW1 and SW2 are located behind the label on the lower right corner of the charger next to the green LED.

SW2: Set the charge current according to the battery amp hour rate (Reference CHARGE CURRENT AND BATTERY AMP HOURS table below).

DP2	DP1	CHARGING CURRENT
ON	ON	15A
ON	OFF	20A
OFF	ON	25A
OFF	OFF	25A

SW1: Set the current profile according to the battery installed.

DP2	DP1	CHARGING CURRENT
OFF	ON	Lead-Acid (Wet) Batteries
OFF	OFF	AGM FULLRIVER
ON	OFF	AGM DISCOVER
ON	ON	Gel

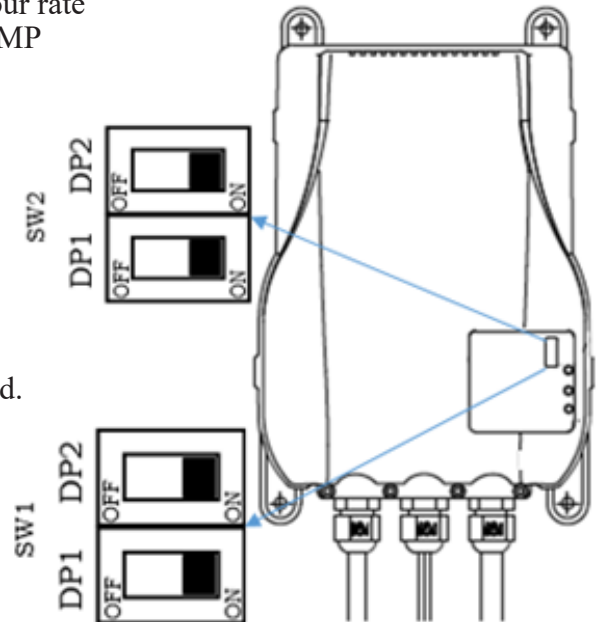

CHARGING CURRENT	BATTERY AMP HOUR RANGE	
	(5h)	(20h)
15A	100-150 Ah	130-180 Ah
20A	120-195 Ah	150-240 Ah
25A	180-258 Ah	220-315 Ah

OFF-BOARD CHARGER

WARNING: Battery posts, terminals, and related accessories contain lead and lead compounds, chemicals known to the State of California to cause cancer and reproductive harm, and during charging, strong inorganic acid mists containing sulfuric acid are involved, a chemical known to the State of California to cause cancer. Wash hands after handling. For more information go to www.P65Warnings.ca.gov.



WARNING: Do not plug in charger cable if wall cord or battery harness is damaged.

NOTE: Ensure battery charging and storage locations comply with OSHA and any governing agencies' standards based on your particular location and application.

Set the **Battery Type** switch to match the battery configuration of the machine.

- Up for Lead Acid batteries.
- Down for sealed, maintenance-free AGM batteries

1. Connect the charger to the wall outlet.
2. Connect the red plug (pictured below) to the battery harness below the control panel at the rear of the machine.

Off-board status LEDs:

- Primary (green) LED:
 - Blinking slowly: Batteries are below 80% of full charge.
 - Blinking rapidly: Batteries are above 80% of full charge.
 - Solid: Batteries are fully charged.
- Fault (red) LED:
 - See the charger manual for fault information.

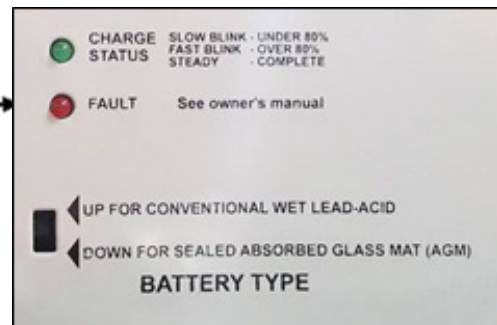
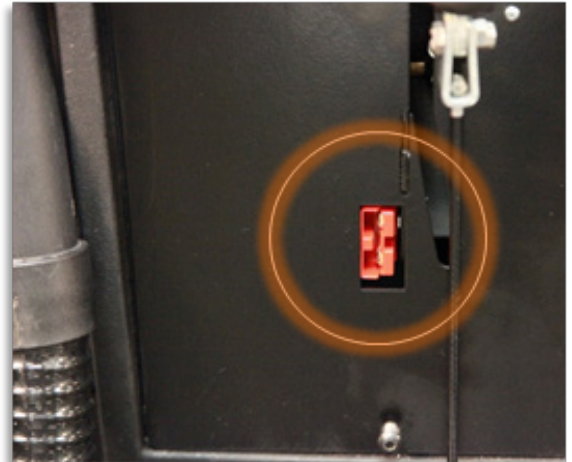

PRE-USE SETUP

TURNING THE UNIT ON/OFF

The key switch is located on the control panel. When the machine is not in use, remove the key and store it in a secure location.

CIRCUIT BREAKERS

The circuit breakers on the control panel protect the components from high amp-draw. In particular, the scrub head circuit will draw too many amps when overloaded by improper application setup. Solution flow, floor surface, and down-pressure should be considered when operating the machine (example: high down-pressure on a rough floor with no solution flow will overload the circuit). Repeatedly tripping the breaker will cause the need for replacement.

BATTERY POWER LEVEL & FAULT INDICATOR

When switched to the ON position, the Battery Power Level Indicator illuminates indicating the battery charge level. A full charge is indicated when all LEDs are lit. As the power level decreases, the LEDs go out from right to left.



When the battery charge is depleted, the last red LED will flash and the brush motor will turn off. The vacuum and traction drive will continue to function allowing final water recovery and transport to the charging station.

NOTE: Using AGM battery-equipped units after the last yellow LED goes out can reduce the life of the batteries.

NOTE: After a full charge, operate the machine for at least 30 minutes before recharging the batteries again. Do not leave the batteries discharged overnight.

A flashing **Battery Power Level Indicator** indicates a detected fault. The following is a list of fault codes:

1 Bar

 The battery needs to be charged or there is a faulty connection to the battery.

2 Bar

 Check the connection to the motor.

3 Bar

 The motor has a short circuit.

6 Bar

 The controller is being inhibited from driving.

7 Bar

 Throttle fault, check the connection.

8 Bar

 Controller fault, check connections

9 Bar

 Parking brake fault, check the motor connections.

10 Bar

 Excessive voltage, check the battery connections.

DRIVE SYSTEM

DRIVING OPERATION

1. Bail: Squeezing the Bail activates solution flow, the brush motor, and traction drive.
2. Speed Control: Rotate the Speed Control with either thumb.
 - Clockwise: Faster
 - Counter-Clockwise: Slower
3. Reverse Button: Depress Reverse Button and squeeze Bail for reverse operation.



SOLUTION DISTRIBUTION

FILLING THE SOLUTION TANK

Use liquid detergent in the concentration and manner specified by the manufacturer for a 22-gallon solution tank. Excess foam will damage the vacuum motor. In addition to properly-mixed low-foam detergent, use a small amount of de-foaming liquid in the recovery tank. Never use pure acids.

NOTE: The front fill port strainer blocks debris from falling into the tank. Keep the solution tank free from debris to prevent filter clogs and reduced solution flow.

1. Add water and cleaning agent via the front or rear fill port. Water temperature should not exceed 120°F (50°C).
2. Monitor the solution level through the sight tube and the marks on the tank at the rear of the machine.
3. To drain the tank, slide the solution sight tube off of the upper fitting and lower to a drain or mop sink.



SOLUTION FLOW: NON-CHEMICAL INJECTION MODELS

The Solution Control Knob is located on the top left corner of the control panel. The valve electrically turns on and off with the Scrub Head. The knob controls how much solution passes through the valve when activated.



OPTIONAL CHEMICAL INJECTION MODELS

1. Place a 1-gallon chemical container in the holder in the battery compartment and remove the cap.
2. Insert the leader hose so that the end is resting on the bottom of the container and screw on the cap.



3. Match the mix ration dial on the control panel to the setting (in ounces per gallon) prescribed on the chemical's container.
4. Set the solution flow rate to low, medium, or high.
5. A solid green LED indicates that the system is automatically mixing the chemical while the machine operates.

NOTE: If the detergent is not priming, temporarily select a higher setting until detergent appears on the floor.

NOTE: To purge old detergent, set the mixture dial to the highest ration and run until the leader hose line is empty.

INSPECTION & CLEANING

NOTE: If excessive debris is present, drain and flush the solution tank.

1. Close the shutoff valve.
2. Remove the filter bowl and screen.
3. Clean and rinse any debris in the filter assembly.

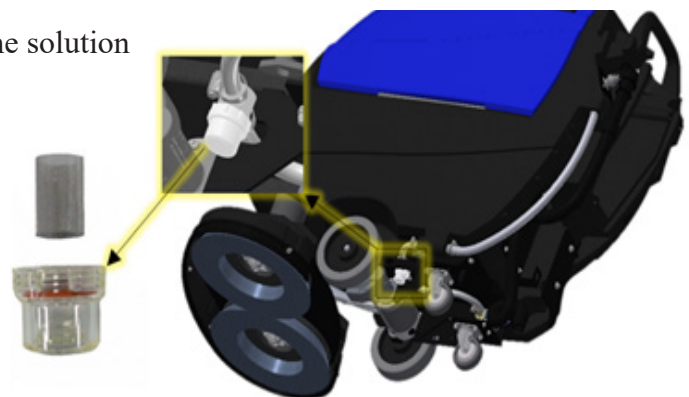

SCRUB DECK SETUP

HEAD LIFT

- Depress the foot lever (located at the lower right rear corner of the machine) and shift it to the right.
- Once clear of the notch, allow the lever to rise while the head lowers into the operating position.
- Disk machines are equipped with a self-adjusting shroud and bristle skirt that virtually eliminates over-spray.



SELECTING DOWN PRESSURE

1. Standard: For daily cleaning of normal soils.
2. Heavy: For toughest soils or chemical-free finish removal.

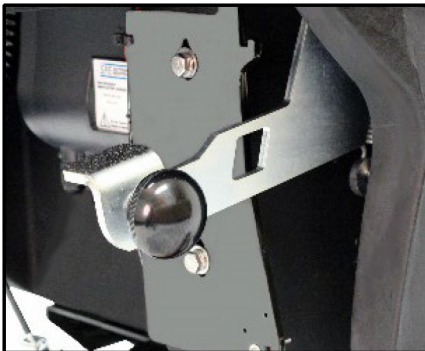

STANDARD DOWN PRESSURE



MEDIUM DOWN PRESSURE



HEAVY DOWN PRESSURE

SCRUB HEAD DOWN PRESSURE			
	24" DISK	28" ORBITAL	28" & 32" DISK
STANDARD	50 lbs (23kgs)	70 lbs (32 kgs)	70 lbs (32 kgs)
MEDIUM	100 lbs (45 kgs)	110 lbs (50 kgs)	110 lbs (50 kgs)
HEAVY	140 lbs (64 kg)	160 lbs (73 kgs)	150 lbs (68 kgs)

ORBITAL PADS & CHEMICAL-FREE FINISH REMOVAL (CFR)

NOTE: Do not lower the orbital head without a pad installed. Doing so may damage the Mighty-Lok® face.

STANDARD CLEANING OPERATIONS

1. Align the corners of the pad to the corners of the aluminum plate and press to attach.



2. Lower the scrub deck onto the pad.
3. Ensure the pad is properly aligned front-to-back and left-to-right.

CHEMICAL-FREE FINISH REMOVAL (CFR) PAD ASSEMBLY

A specialized surface preparation pad, in addition to the traditional cleaning pad, is required for chemical-free finish removal. The traditional pad acts as a “backer pad” and compensates for variances in the floor.

1. Place the black retainer pad 2” back from the front of the red scrub pad and the maroon CFR pad to allow water saturation.
2. Align and assemble the pads with the red pad on top and the maroon pad on the bottom facing the floor.
3. Ensure the gap mentioned in step 1 is facing forward and refer to steps 1-3 of “**Standard Cleaning Operations**” above to install the CFR Pad Assembly.



MACHINE SETUP

1. Install the CFR Pad Assembly as described above.
2. Fill the solution tank with clean water.
3. Set the down pressure to Heavy (see “Selecting Down Pressure” above).
4. Set the solution flow to midrange. Adjust as needed for maximum finish removal, using the least amount of water needed for effective rinsing.
5. Adjust the machine speed as required.

DISK MACHINE PAD DRIVERS & BRUSHES

PAD & BRUSH REMOVAL

NOTE: Using a pad driver without a pad will damage the floor surface.

1. Toggle the “Brush On/Off” switch to position “A” for 1 second and then immediately to position “B”. The brush will spin in position “A” and abruptly stop in position “B”, releasing the pad drivers.
2. Remove the center lock fitting by squeezing the wires inward and pulling the center lock away.
3. To connect the cleaning pad to the drivers, center the pad on the driver, squeeze the center lock wires inward, and press down (tab side first). Press the pad and release the wires so that they lock in place.

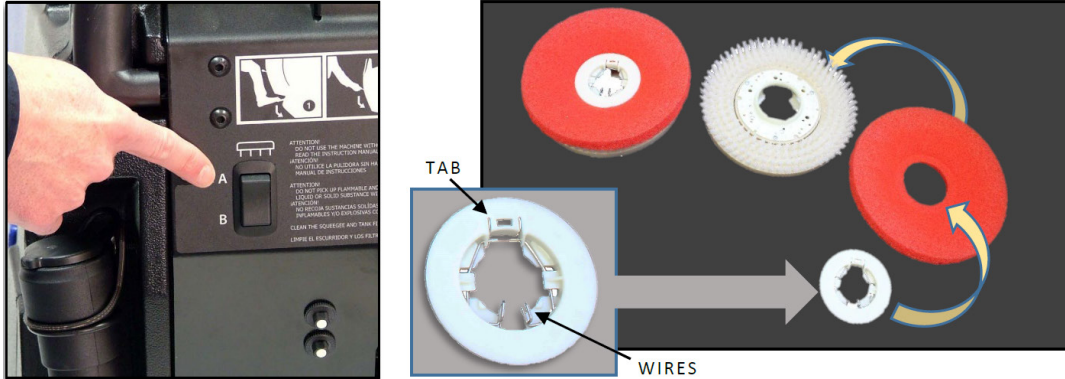

PAD & BRUSH INSTALLATION

1. Turn the key switch on and rotate the speed control knob to the full slow position.
2. Place the pad drivers or brushes on the floor in front of the scrub head.
3. Push or drive the machine into position centering the scrub head over the pad drivers or brushes.
4. Lower the scrub deck onto the pad drivers or brushes.



NOTE: When properly aligned, the scrub deck shroud bristle skirt should almost be touching the floor.

5. Quickly pulse and release the activation trigger to “CLICK ON” the pad drivers or brushes.

NOTE: If the pad drivers or brushes do not quickly engage, return to step two and try again.

RECOVERY SYSTEM

RECOVERY TANK

To drain and rinse the recovery tank:

1. Lift the hose off the holder and lower the hose end to the desired drain location.
2. Remove the press-fit cap from the drain hose and squeeze the restriction collar to control the flow.
3. As the tank drains, lift the recovery tank lid to the fully open position.
4. Thoroughly clean and rinse out the sediment from the bottom of the tank with a clean water hose.
 - Periodically use cleaner and sanitizer with a cloth or sponge to prevent mold and mildew.
5. Inspect and clean the debris tray and the vacuum mesh filter screen and ball float system.
6. Leave the lid open to dry

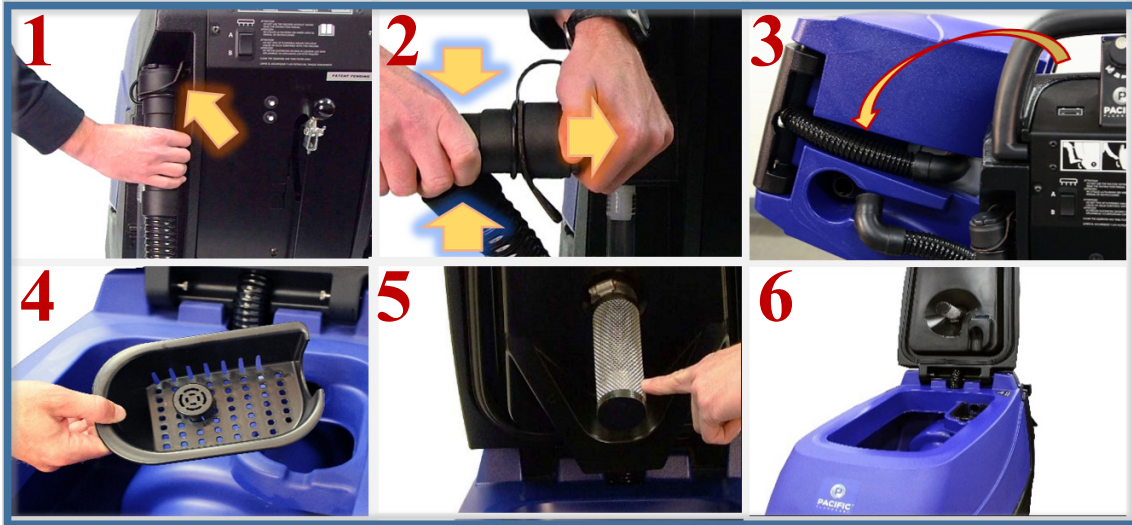

OPTIONAL TANK TREATMENT

The Tank Treatment System (TTS) utilizes Bromine tablets (typically used in pools and spas) to kill the odor-causing bacteria in the tank. To ensure that the TTS is prepared to treat your recovery tank:

1. Lift the debris tray out and pinch the two tabs sticking through the underside of the tray.
2. Check the size of the Bromine puck. Replace it when it is approximately 25% of its original size.
3. Press the TTS holder and bromine puck back into the debris tray.

CAUTION: Use Bromine only! Do not use chlorine! Chlorine can interact with ammonia-based detergents to cause harmful fumes.

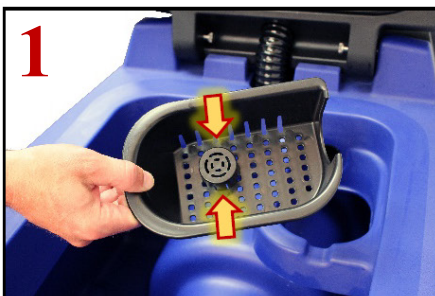

SQUEEGEE SYSTEM

SQUEEGEE ASSEMBLY SETUP

Inspect and maintain the squeegee system to achieve peak machine performance.

REMOVAL & INSTALLATION

- Install: Align the assembly, attach the vacuum hose, and tighten the easy grip knobs.
- Remove: Loosen the easy-grip knobs and detach the recovery hose (reverse of installation).

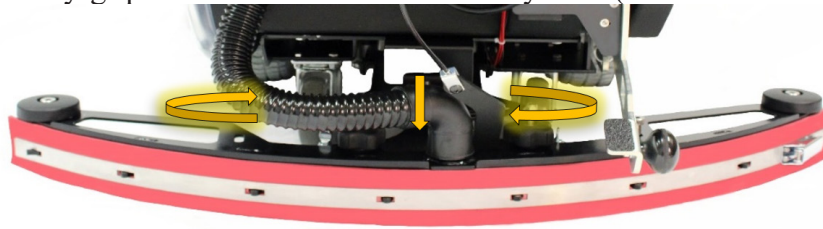

SQUEEGEE USE

1. Lower: Lift the squeegee lever, shift it left, and lower. The vacuum motor will activate.
2. Raise: Lift the lever and shift it right. The vacuum motor will run for 10 seconds to prevent recovered solution from running back out of the hose.



HEIGHT ADJUSTMENT

If the squeegee blade height requires adjustment, turn the button screws on the squeegee frame assembly clockwise to raise and counter-clockwise to lower the wheels until proper blade deflection is achieved.

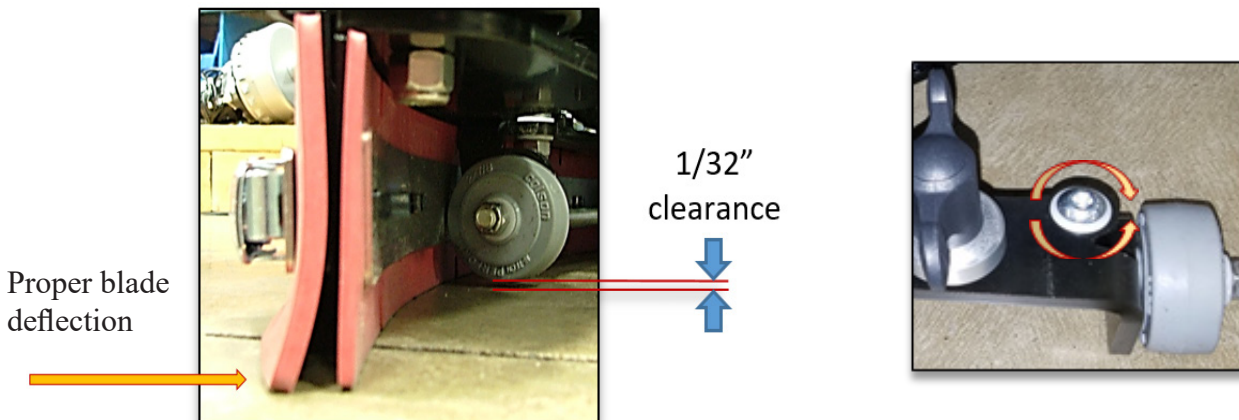

CLEAN & INSPECT

1. Inspect both squeegee blades. If the blade edges are not clearly defined or are worn halfway through the thickness of the blade, flip the blades to another edge or replace as required.
2. Thoroughly clean and rinse the underside of the squeegee frame, blades and neck.

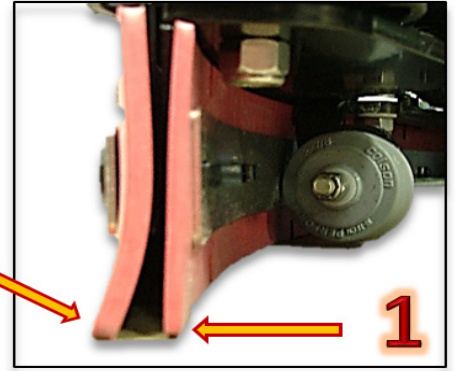

REMOVE & INSTALL SQUEEGEE BLADES

1. Release the over-center latch and slide the band clamp off the hook on the other side.
2. Blades can be flipped length wise or top to bottom to utilize another blade edge.
3. Blade installation is the reverse of the removal.

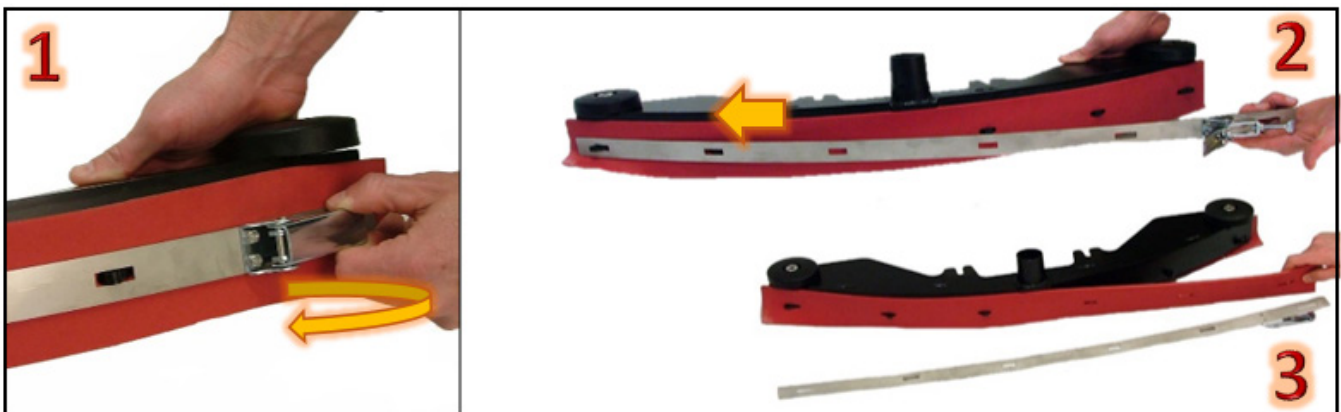

PAGE INTENTIONALLY BLANK

RECOMMENDED MAINTENANCE

SYSTEM	REFERENCE SECTION	DAILY	WEEKLY	MONTHLY	BIANNUALLY
CONTROL PANEL					
INSPECT ALL CONTROLS AND HARDWARE FOR SECURITY AND SERVICEABILITY	PARTS DIAGRAMS	X			
VERIFY PROPER OPERATION OF ALL CONTROLS	ALL	X			
SOLUTION DISTRIBUTION					
VERIFY SOLUTION FLOWS AND ADJUSTS AS EXPECTED	SOLUTION DISTRIBUTION	X			
CLEAN AND INSPECT IN-LINE FILTER	SOLUTION DISTRIBUTION			X	
FLUSH TANK WITH FRESH WATER	SOLUTION DISTRIBUTION			X	
SCRUB DECK					
RINSE BRUSHES & PADS	SCRUB DECK SETUP	X			
RINSE & DRY SCRUB DECK	SCRUB DECK SETUP	X			
CLEAN MOTOR VENTS	PARTS DIAGRAMS			X	
INSPECT ISOLATORS *(ORBITAL ONLY)	PARTS DIAGRAMS				X
INSPECT LIFT LINKAGE & PIVOT BLOCKS	SCRUB DECK SETUP				X
RECOVERY SYSTEM					
RINSE & AIR DRY RECOVERY TANK	RECOVERY SYSTEM	X			
CLEAN & INSPECT DEBRIS TRAY	RECOVERY SYSTEM	X			
VERIFY DRAIN HOSE CAP IS SEALED TIGHT WHEN INSTALLED	RECOVERY SYSTEM	X			
INSPECT LID SEAL	RECOVERY SYSTEM		X		
INSPECT / REPLACE BROMINE PUCK *(IF EQUIPPED)	RECOVERY SYSTEM		X		
INSPECT HEPA FILTER *(IF EQUIPPED)	RECOVERY SYSTEM				X
CLEAN & SANITIZE RECOVERY TANK	RECOVERY SYSTEM			X	
BATTERIES AND CHARGER					
INSPECT TERMINALS & CABLES FOR SECURITY, CORROSION, OR DAMAGE	BATTERIES			X	
SERVICE LEAD ACID BATTERIES *(IF EQUIPPED)	BATTERIES		X		
CLEAN ONBOARD CHARGER VENTS *(IF EQUIPPED)	PARTS DIAGRAMS			X	
CLEAN BATTERYSHIELD* LIGHT PIPE *(IF EQUIPPED)	BATTERIES				X
PERFORM BATTERYSHIELD* OPERATIONAL CHECKS *(IF EQUIPPED)	BATTERIES				X
SQUEEGEE ASSEMBLY					
CLEAN & INSPECT SQUEEGEE ASSEMBLY & BLADES	RECOVERY SYSTEM	X			
INSPECT VACUUM HOSE	RECOVERY SYSTEM		X		
CHASSIS AND UNDERCARRIAGE					
CLEAN & INSPECT WHEELS & CASTERS	PARTS DIAGRAMS			X	
CLEAN & INSPECT LINKAGES, CHASSIS & HARDWARE	PARTS DIAGRAMS			X	
CLEAN & INSPECT VISIBLE WIRES FOR DAMAGE & SECURITY	PARTS DIAGRAMS				X

RECOMMENDED SERVICE PARTS

(PAGE 1 OF 3)

PART NUMBER	DESCRIPTION	DIAGRAM CATEGORY	WEAR ITEM	S-24	S-28 DISK	S-32	S-28 ORB	OPTIONAL
903046	BELT, V-GROOVE, STRETCH	SCRUB HEAD	X	X				
870702	BLADE, FRONT, 35INCH (LINATEX)	SQUEEGEE	X	X				
870708	BLADE, FRONT, 35INCH (URETHANE)	SQUEEGEE	X	X				
870704	BLADE, FRONT, 40INCH (LINATEX)	SQUEEGEE	X		X		X	
870710	BLADE, FRONT, 40INCH (URETHANE)	SQUEEGEE	X		X		X	
870706	BLADE, FRONT, 44.5INCH (LINATEX)	SQUEEGEE LINK	X	X	X	X	X	
870712	BLADE, FRONT, 44.5INCH (URETHANE)	SQUEEGEE LINK	X	X	X	X	X	
870701	BLADE, REAR, 35INCH (LINATEX)	SQUEEGEE	X	X				
870707	BLADE, REAR, 35INCH (URETHANE)	SQUEEGEE	X	X				
870703	BLADE, REAR, 40INCH (LINATEX)	SQUEEGEE	X		X		X	
870709	BLADE, REAR, 40INCH (URETHANE)	SQUEEGEE	X		X		X	
870705	BLADE, REAR, 44.5INCH (LINATEX)	SQUEEGEE LINK	X	X	X	X	X	
870711	BLADE, REAR, 44.5INCH (URETHANE)	SQUEEGEE LINK	X	X	X	X	X	
911681	BREAKER, CIRCUIT, 35 AMPS	CONTROLS			X	X		
850906	BRUSH CARBON KIT 4 PC 855204 & 875201	SCRUB HEAD	X	X	X	X	X	
870919	BRUSH KIT REPL FOR TRANSAXLE 879203	FRAME ASSEMBLY	X	X	X	X	X	
870909	BRUSH, GRIT, 12 INCH	SCRUB HEAD	X	X				
870906	BRUSH, GRIT, 14 INCH	SCRUB HEAD	X		X			
870907	BRUSH, GRIT, 16 INCH	SCRUB HEAD	X			X		
870908	BRUSH, NYLON, 12 INCH	SCRUB HEAD	X	X				
870904	BRUSH, NYLON, 14 INCH	SCRUB HEAD	X		X			
870905	BRUSH, NYLON, 16 INCH	SCRUB HEAD	X			X		
870902	BRUSH, POLY, 12 INCH	SCRUB HEAD	X	X				
870901	BRUSH, POLY, 14 INCH	SCRUB HEAD	X		X			
852401	CABLE, LIFT, CLEVIS	CONTROLS		X	X	X	X	
871501	CAP, 38MM, WITH HOLE	CHEMICAL INJECTION	X					X
911622	CIRCUIT BREAKER, 30 AMPS	CONTROLS		X	X	X	X	
912401	CONTACTOR, 24V, 100A	ELECTRONICS		X	X	X	X	
912402	CONTACTOR, 24VDC, 70A	ELECTRONICS		X	X	X	X	
875902	DRIVER, PAD, 14 INCH	SCRUB HEAD	X		X			

RECOMMENDED SERVICE PARTS

(PAGE 2 OF 3)

PART NUMBER	DESCRIPTION	DIAGRAM CATEGORY	WEAR ITEM	S-24	S-28 DISK	S-32	S-28 ORB	OPTIONAL
875910	DRIVER, PAD, 16 INCH	SCRUB HEAD	X			X		
873304	FILTER, HEPA, MID	RECOVERY TANK	X	X	X	X	X	
843319	FILTER, SCREEN, BOWL	FRAME ASSEMBLY	X	X	X	X	X	
S764P2	FILTER, STRAINER	CHEMICAL INJECTION	X					X
223370	FLOAT, SHUTOFF	RECOVERY TANK		X	X	X	X	
873314	GASKET, FOAM, VACUUM	RECOVERY TANK		X	X	X	X	
853803	GUIDE, DRIVER	SCRUB HEAD	X	X	X	X		
873802	GUIDE, DRIVER, RH	SCRUB HEAD	X	X	X	X		
853804	GUIDE, PAD, PLASTIC	SCRUB HEAD	X		X	X		
873801	GUIDE, PAD, PLASTIC	SCRUB HEAD	X	X				
854101	HOSE, DRAIN, CAPPED	RECOVERY TANK	X	X	X	X	X	
874101	HOSE, SQUEEGEE, 90 CUFF	RECOVERY TANK	X	X	X	X	X	
854103	HOSE, VACUUM, 1.5INCH	RECOVERY TANK		X	X	X	X	
854302	HUB, DRIVER, BRUSH	SCRUB HEAD	X		X	X		
874305	HUB, PULLEY, MACH FLAT	SCRUB HEAD	X	X				
874306	HUB, PULLEY, MACH GROOVED	SCRUB HEAD	X	X				
875017	KIT CASTER 4 INCH REPLACEMENT	FRAME ASSEMBLY	X	X	X	X	X	
875010	KIT, BEARING, REPL, ORBIT	SCRUB HEAD	X				X	
875009	KIT, PLATE, REPL, ORBIT	SCRUB HEAD	X				X	
875202	MOTOR, VACUUM, 24VDC, 3-STAGE	RECOVERY TANK		X	X	X	X	
555901	PAD 12" BLACK STRIP CASE 5	SCRUB HEAD	X	X				
555941	PAD 12" RED SCRUB CASE 5	SCRUB HEAD	X	X				
555951	PAD 12" WHITE POLISH CASE 5	SCRUB HEAD	X	X				
555902	PAD 14" BLACK STRIP CASE 5	SCRUB HEAD	X		X			
555942	PAD 14" RED SCRUB CASE 5	SCRUB HEAD	X		X			
555952	PAD 14" WHITE POLISH CASE 5	SCRUB HEAD	X		X			
555909	PAD 14"X28" BLACK STRIP CASE 5	SCRUB HEAD	X			X		
555929	PAD 14"X28" MAROON CFR CASE 10	SCRUB HEAD	X			X		
555949	PAD 14"X28" RED SCRUB CASE 5	SCRUB HEAD	X			X		

RECOMMENDED SERVICE PARTS

(PAGE 3 OF 3)

PART NUMBER	DESCRIPTION	DIAGRAM CATEGORY	WEAR ITEM	S-24	S-28 DISK	S-32	S-28 ORB	OPTIONAL
555969	PAD 14"X28" TURF CASE 4	SCRUB HEAD	X			X		
555959	PAD 14"X28" WHITE POLISH CASE 5	SCRUB HEAD	X			X		
555903	PAD 16" BLACK STRIP CASE 5	SCRUB HEAD	X				X	
555943	PAD 16" RED SCRUB CASE 5	SCRUB HEAD	X				X	
555953	PAD 16" WHITE POLISH CASE 5	SCRUB HEAD	X				X	
875903	PAD, MIGHTYLOK ADH UNIVERSAL	SCRUB HEAD	X				X	
875906	PAD, RETAINER, 12X28	SCRUB HEAD	X				X	
857003	PUMP ASSY HAND HYDROLINK	BATTERIES	X					X
858503	SKIRT, BRISTLE	SCRUB HEAD	X	X				
878502	SKIRT, BRISTLE	SCRUB HEAD	X		X	X		
911647	SWITCH, KEY	CONTROLS		X	X	X	X	
911649	SWITCH, ROCKER, AUTO ON-OFF	CONTROLS		X	X	X		
911653	SWITCH, ROUND, ON - MOM	CONTROLS		X	X	X	X	
911682	SWITCH, SNAP, BENT LEVER	FRAME ASSEMBLY		X	X	X	X	
911646	SWITCH, SNAP, WITH ROLLER	CONTROLS		X	X	X	X	
879201	TRAY, DEBRIS	RECOVERY TANK	X	X	X	X	X	
879202	TRAY, PUCK	RECOVERY TANK	X	X	X	X	X	
855022	KIT-GUIDE WHEEL REPL, ANTI-RATTLE	SCRUB HEAD	X	X	X	X	X	
879705	WHEEL, URETHANE, 222MM	FRAME ASSEMBLY		X	X	X	X	

TROUBLESHOOTING GUIDE

(PAGE 1 OF 2)

ISSUE	POTENTIAL CAUSE	PROPOSED SOLUTION	MANUAL SECTION
INSUFFICIENT WATER TO SCRUB HEAD	SOLUTION FLOW SETTING IS TOO LOW	ADJUST SOLUTION CONTROL	SOLUTION DISTRIBUTION
	SOLUTION TANK IS EMPTY	ADD WATER/SOLUTION TO THE TANK	SOLUTION DISTRIBUTION
	IN-LINE SOLUTION FILTER IS CLOGGED	REMOVE AND CLEAN THE FILTER	SOLUTION DISTRIBUTION
	SOLUTION TUBE IS CLOGGED, KINKED, OR DAMAGED	INSPECT TUBES	PARTS DIAGRAMS
	SOLUTION SHUT OFF VALVE IS CLOSED	OPEN VALVE	SOLUTION DISTRIBUTION
	SOLUTION SOLENOID VALVE MAY BE FAULTY	VERIFY OPERATION AND REPLACE IF NECESSARY	PARTS DIAGRAMS
POOR WATER RECOVERY	RECOVERY TANK IS FULL	EMPTY RECOVERY TANK	RECOVERY SYSTEM
	DIRTY OR WORN SQUEEGEE BLADES	INSPECT AND ROTATE OR REPLACE AS REQUIRED	RECOVERY SYSTEM
	RECOVERY HOSE LOOSE OR DAMAGED	INSPECT AND REPAIR	PARTS DIAGRAMS
	RECOVERY HOSE OR SQUEEGEE ASSEMBLY HAS AN OBSTRUCTION	CLEAR OBSTRUCTIONS FROM RECOVERY SYSTEM	PARTS DIAGRAMS
	SQUEEGEE ASSEMBLY MAY BE OUT OF ADJUSTMENT	ADJUST AS NECESSARY	RECOVERY SYSTEM
	STUCK OR DAMAGED BALL FLOAT	INSPECT AND REPAIR/REPLACE	RECOVERY SYSTEM
	RECOVERY TANK LID IS NOT SEALING PROPERLY	INSPECT RECOVERY LID GASKET. REPAIR OR REPLACE IF NEEDED	PARTS DIAGRAM
	DRAIN HOSE CAP IS NOT INSTALLED PROPERLY	INSTALL DRAIN HOSE SECURELY	RECOVERY SYSTEM
MACHINE WILL NOT TURN ON	LOW BATTERY VOLTAGE	CHARGE BATTERIES	CHARGING
	FAULTY KEY SWITCH	DIAGNOSE AND REPLACE	WIRING DIAGRAMS
	DISCHARGED BATTERIES	CHARGE BATTERIES	CHARGING
MACHINE NOT CLEANING FLOOR PROPERLY	LOOSE OR DAMAGED WIRE	REPAIR	WIRING DIAGRAMS
	WORN PAD OR BRUSH	INSPECT AND REPLACE AS REQUIRED	SCRUB DECK SETUP
	WRONG PAD OR BRUSH FOR APPLICATION	CONTACT YOUR LOCAL DISTRIBUTOR FOR RECOMMENDED APPLICATION	SCRUB DECK SETUP
EXCESSIVE FOAM IN RECOVERY TANK	INSUFFICIENT CLEANING SOLUTION FOR APPLICATION	ADJUST THE MIXTURE AS REQUIRED	SOLUTION DISTRIBUTION
	IMPROPER DETERGENT TYPE	USE A LOW-FOAM DETERGENT OR ADD A DEFOAMING AGENT TO THE RECOVERY TANK. READ ALL CHEMICAL LABELS THOROUGHLY BEFORE USE	RECOVERY SYSTEM
VACUUM MOTOR WILL NOT RUN	MIXTURE SETTING TOO HIGH ON OPTIONAL CHEMICAL INJECTION SYSTEM	USE A LOW-FOAM DETERGENT OR ADD A DEFOAMING AGENT TO THE RECOVERY TANK. READ ALL CHEMICAL LABELS THOROUGHLY BEFORE USE	RECOVERY SYSTEM
	SQUEEGEE LIFT LEVER IS STILL RAISED	LOWER SQUEEGEE LEVER	RECOVERY SYSTEM
	VACUUM RELAY MAY BE FAULTY	CONTACT SERVICE TECHNICIAN TO TROUBLESHOOT AND ISOLATE	WIRING DIAGRAMS
VACUUM MOTOR WILL NOT TURN OFF	VACUUM SWITCH OR WIRING MAY BE FAULTY	CONTACT SERVICE TECHNICIAN TO TROUBLESHOOT AND ISOLATE	WIRING DIAGRAMS
	STILL IN DELAY MODE	ALLOW 10 SECONDS FOR VACUUM TO SHUT DOWN	RECOVERY SYSTEM
	VACUUM RELAY MAY BE FAULTY	CONTACT SERVICE TECHNICIAN TO TROUBLESHOOT AND ISOLATE	WIRING DIAGRAM

TROUBLESHOOTING GUIDE

(PAGE 2 OF 2)

ISSUE	POTENTIAL CAUSE	PROPOSED SOLUTION	MANUAL SECTION
SCRUB HEAD WILL NOT RUN	SCRUB HEAD IS STILL RAISED	LOWER SCRUB HEAD	SCRUB DECK SETUP
	BATTERYSHIELD® LED IS ILLUMINATED AND HAS DISABLED THE SCRUB HEAD (IF EQUIPPED)	SERVICE THE BATTERIES	BATTERIES
	BATTERIES ARE DISCHARGED BELOW THRESHOLD VOLTAGE	CHARGE BATTERIES	CHARGING
	BRUSH MOTOR CIRCUIT BREAKER HAS TRIPPED	SEE NEXT TOPIC ON THIS TABLE	TROUBLESHOOTING TABLE
	SCRUB HEAD LIFT ARM SWITCH MAY BE STUCK OR FAULTY	INSPECT AND REPAIR SWITCH AS REQUIRED	PARTS DIAGRAMS
	TRIGGER SWITCH IN HANDLE MAY BE FAULTY	INSPECT AND REPAIR AS REQUIRED	PARTS DIAGRAMS
	SOLUTION SOLENOID VALVE MAY HAVE AN INTERNAL SHORT	DISCONNECT WIRES FROM SOLENOID VALVE AND TRY RUNNING THE SCRUB HEAD AGAIN. REPLACE SOLENOID IF REQUIRED	WIRING DIAGRAM
	BATTERYSHIELD® RELAY MAY BE FAULTY (IF EQUIPPED)	CONTACT SERVICE TECHNICIAN TO TROUBLESHOOT AND ISOLATE	WIRING DIAGRAM
SCRUB HEAD CIRCUIT BREAKER IS TRIPPED	INADEQUATE SOLUTION FOR APPLICATION	INCREASE SOLUTION TO SCRUB HEAD	PRE-USE SETUP
	SCRUB HEAD IS SET TO HEAVY DOWN PRESSURE	REDUCE DOWN PRESSURE SETTING	PRE-USE SETUP
	PAD IS TOO AGGRESSIVE FOR APPLICATION	CONTACT YOUR LOCAL DISTRIBUTOR FOR RECOMMENDED APPLICATION	PRE-USE SETUP
	FAULTY OR SHORTED WIRE	REPAIR	WIRING DIAGRAM
	WEAK CIRCUIT BREAKER	CONTACT SERVICE TECHNICIAN TO TROUBLESHOOT AND ISOLATE. BREAKER SHOULD NOT TRIP BELOW ITS STATED RATING	PARTS DIAGRAMS
MACHINE WILL NOT DRIVE	CIRCUIT BREAKER MAY BE TRIPPED	INSPECT AND RESET. IF PROBLEM PERSISTS CONTACT SERVICE TECHNICIAN	PRE-USE SETUP
	BATTERY METER IS FLASHING A FAULT CODE	REFERENCE FAULT CODE AND TROUBLESHOOT AS REQUIRED	PRE-USE SETUP
	BATTERIES DISCHARGED TOO LOW	CHARGE BATTERIES	CHARGING
	SPEED CONTROL KNOB TURNED ALL THE WAY DOWN	INCREASE SPEED SETTING	DRIVE SYSTEM
	FAULTY CONTROLLER	CONTACT SERVICE TECHNICIAN TO TROUBLESHOOT AND ISOLATE	WIRING DIAGRAM
	FAULTY WIRING	CONTACT SERVICE TECHNICIAN TO TROUBLESHOOT AND ISOLATE	WIRING DIAGRAM
RUN TIME IS SHORT	BATTERIES ARE LOW ON WATER (LEAD ACID ONLY)	SERVICE BATTERIES	BATTERIES
	CHARGER IS NOT SET PROPERLY FOR BATTERY TYPE	SET CHARGER TO BATTERY SPECIFICATIONS	CHARGING
	SCRUB HEAD IS IN HEAVY DOWN PRESSURE	REDUCE SCRUB HEAD PRESSURE	PRE-USE SETUP
	BATTERY CHARGER IS NOT ABLE TO FINISH CHARGE CYCLE	CONFIRM A STEADY GREEN LED AFTER THE CHARGE CYCLE (BEFORE UNPLUGGING FROM THE OUTLET)	CHARGING
	BATTERIES ARE DEFECTIVE OR AT THE END OF THEIR LIFE	CONTACT SERVICE TECHNICIAN TO TROUBLESHOOT AND ISOLATE	BATTERIES

BATTERIES, BATTERYSHIELD® & HYDROLINK®

ITEM	QTY	PART NUMBER	DESCRIPTION
1	4	871301	BATTERY, 6V, 260AH, LA
2	4	871302	BATTERY, 6V, 250AH, MF (NOT SHOWN, OPTIONAL)
3	1	858202	FOAM, SPACER, BATTERY
4	3	911640	HARNESS, CONN, BATTERY
5	1	911641	HARNESS, CONN, BATTERY
6	1	878520	SENSOR ASSY BATTERYSHIELD FIELD REPLACE
7	1	879002	COMPLETE SETS MANIFOLDS (BATT CAP), SERVICE TUBE & PUMP
8	1	857003	PUMP ASSY HAND HYDROLINK
9	1	855605	MANIFOLD INDIV HYDROLINK (BATT CAP)

7 COMES WITH 4 MANIFOLDS (BATT CAPS), SERVICING TUBE (NOT PICTURED), AND HAND PUMP

BATTERYSHIELD® SENSOR IS MATED AND CALIBRATED TO THE MANIFOLD (BATT CAP) FROM THE FACTORY. SENSOR AND CAP MUST BE REPLACED AS AN ASSEMBLY – **DO NOT REMOVE SENSOR FROM CAP**

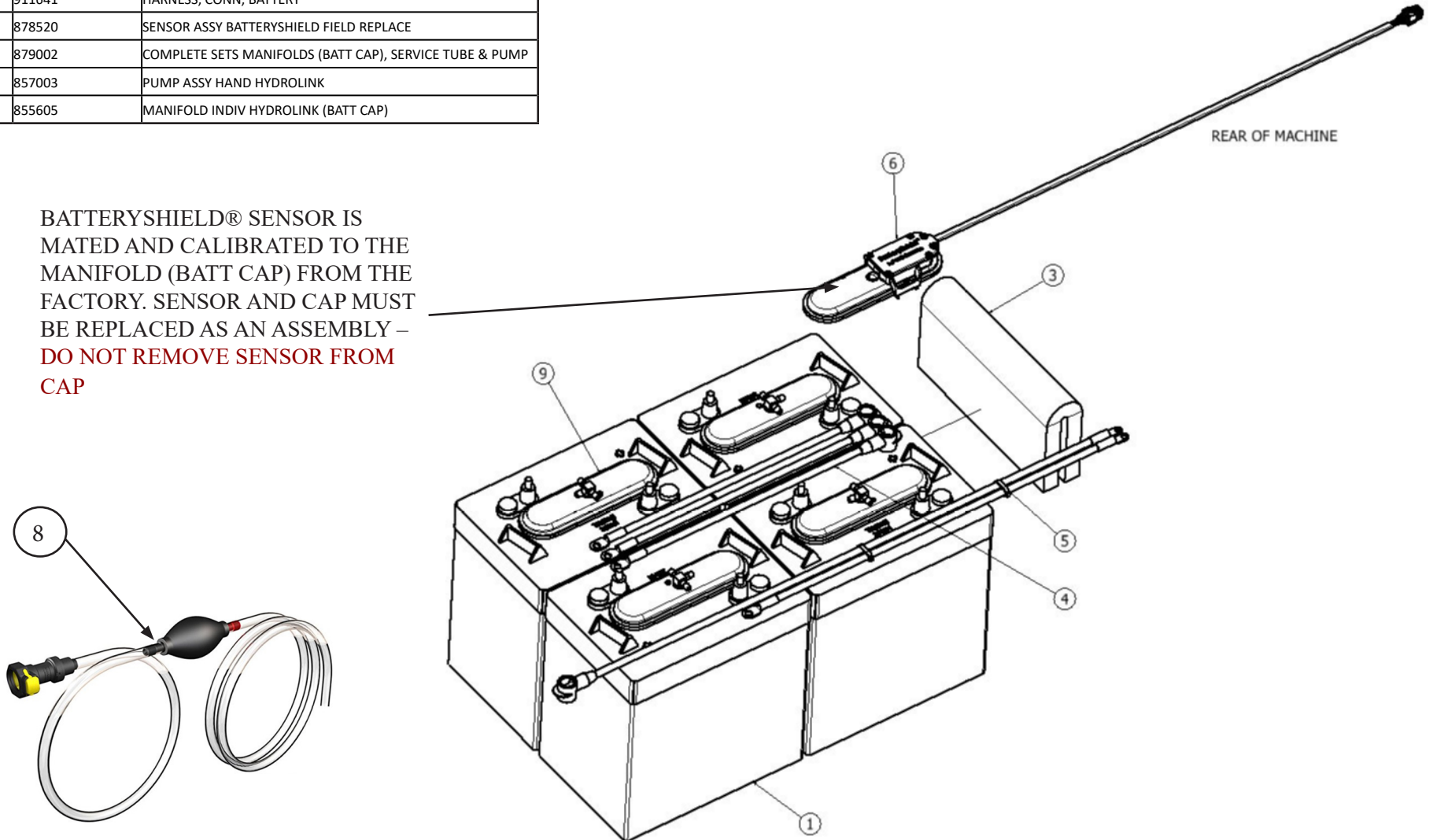

OPTIONAL ONBOARD CHARGER

ITEM	QTY	PART NUMBER	DESCRIPTION
1	1	852407	CHARGER, 24V, ONBRD, CULUS
2	1	850805	BRACKET, MTG, CORD
3	1	870817	BRACKET, MTG, CHARGER
4	4	962186	SCREW, PAN, #10-32 X 1.0, SS
5	6	W401D	WASHER, FLAT, #10
6	4	920666	NUT, NYLOCK, #10-32, SS
7	2	W104D	WASHER, FLAT, .25
8	2	980002	WASHER, LOCK, SPLIT, .25
9	1	920034	NUT, NYLOCK, #6-32, SS
10	2	962263	SCREW, BUTT, SOCK, .25-20X.62, SS BO
11	1	911645	HARNESS, CHARGER, POST
12	1	W323D	SCREW, PAN, #6-32 X 1.0, ZINC
14	2	W189D	SCREW, HEX, 1/4-20 X .75, SS, PATCH
15	2	501210	BUMPER

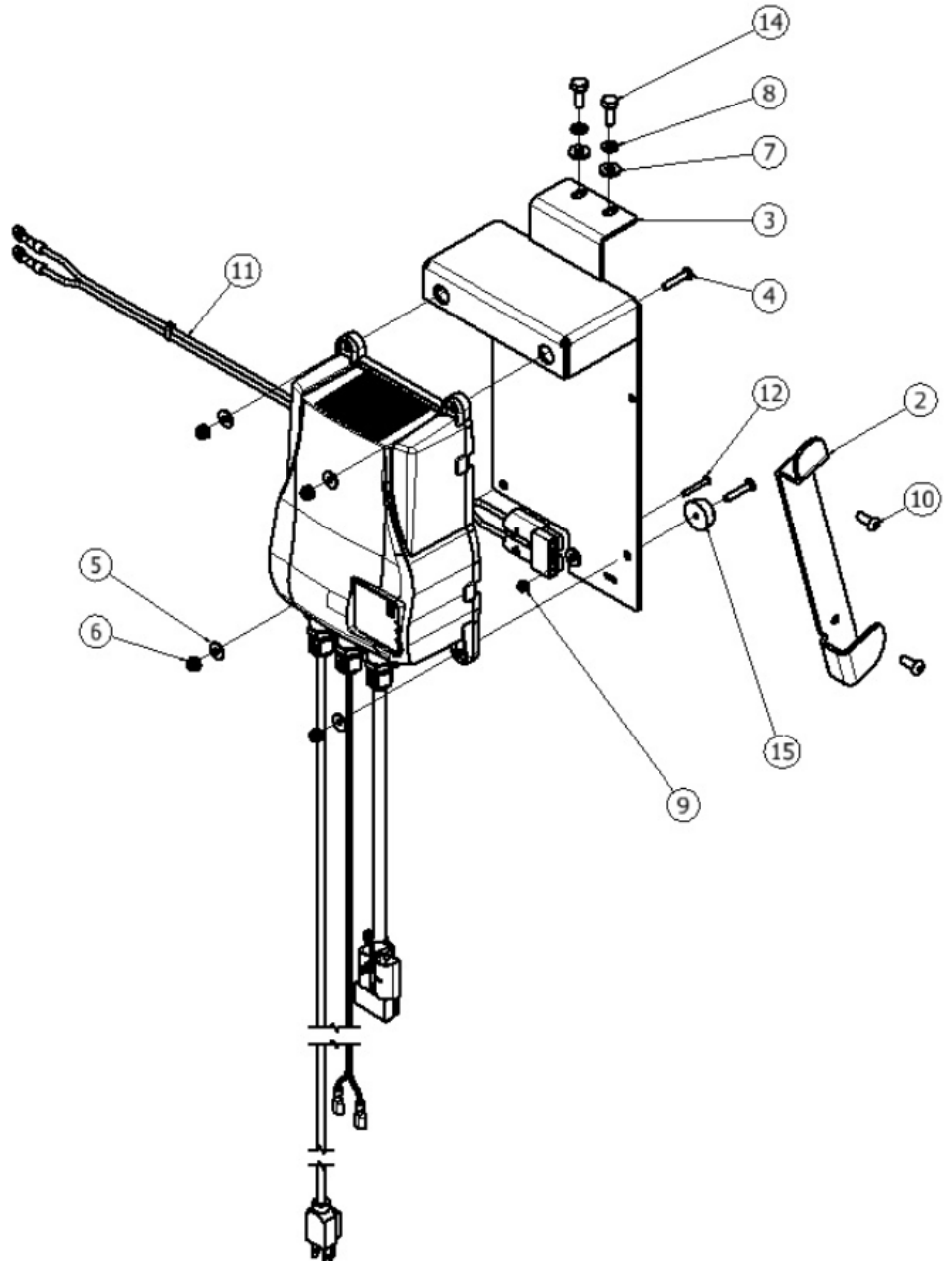

RETURN TO
TABLE OF
CONTENTS

S-24 DISK CONTROLS

(SEE ADDITIONAL DIAGRAM FOR MODELS EQUIPPED WITH BATTERYSHIELD® OR CHEMICAL INJECTION)

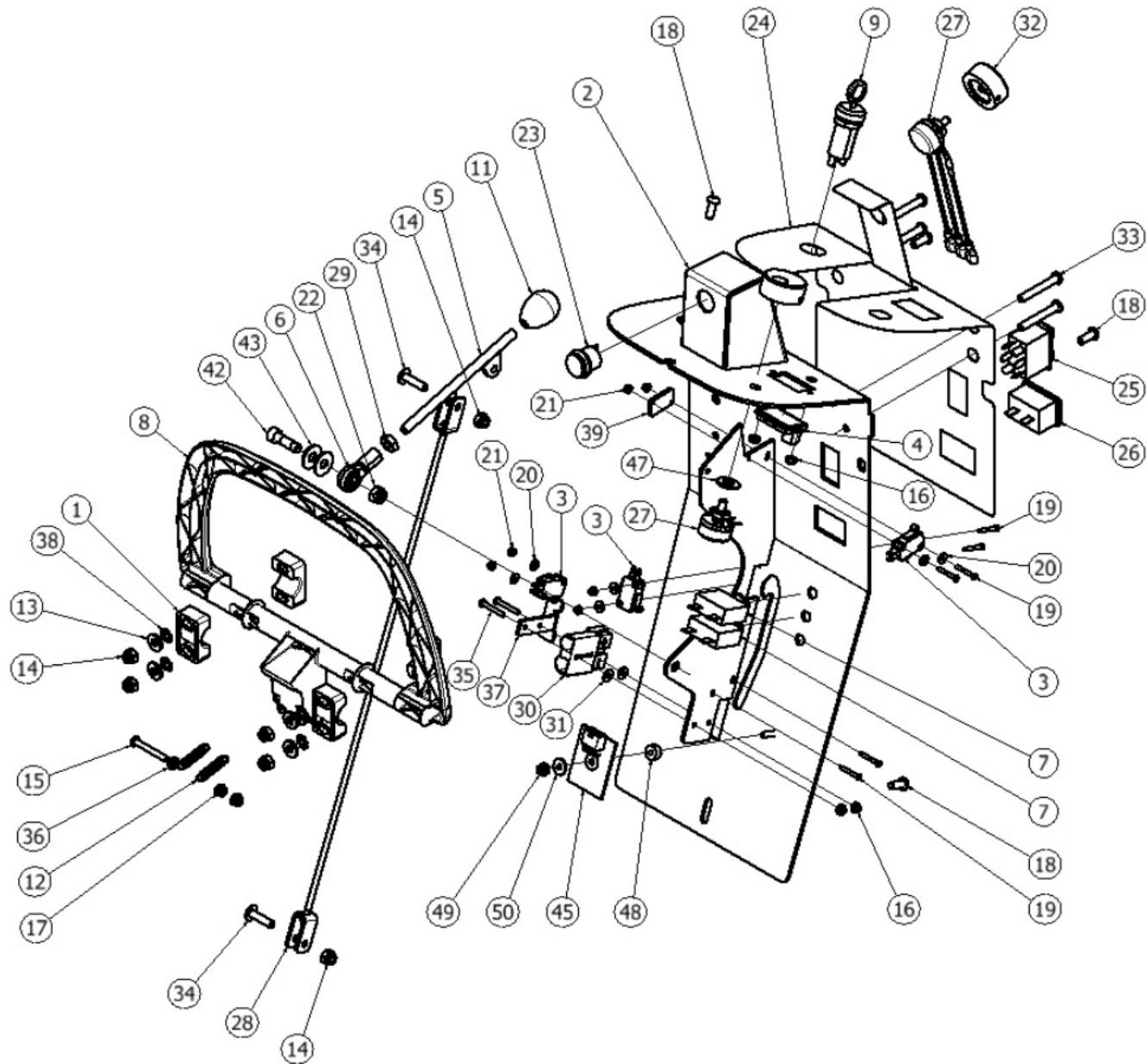

S-24 DISK CONTROLS

(SEE ADDITIONAL DIAGRAM FOR MODELS EQUIPPED WITH BATTERYSHIELD® OR CHEMICAL INJECTION)

ITEM	QTY	PART NUMBER	DESCRIPTION
1	4	855601	MOUNT, BEARING, PLASTIC
2	1	877101	PANEL, CONTROLS
3	3	911646	SWITCH, SNAP, WITH ROLLER
4	1	911621	METER, BATTERY
5	1	855106	LEVER, LIFT, SQUEEGEE
6	1	902050	BEARING, ROD END, .31-24
7	2	911622	CIRCUIT BREAKER, 30 AMPS
8	1	851301	BAIL, MOLDED
9	1	911647	SWITCH, KEY
10	1	855012	KEY REPLMNT SCRUB 2-SET FOR 911647
11	1	855004	KNOB, OVAL, .31-18
12	2	858302	SPRING, EXTENSION
13	4	W104D	WASHER, FLAT, .25
14	6	920011	NUT, NYLOCK, 1/4-20, ZINC
15	1	962146	SCREW, PAN, #10-32 X 1.5, FULL, ZINC
16	4	920034	NUT, NYLOCK, #6-32, SS
17	2	920666	NUT, NYLOCK, #10-32, SS
18	4	962263	SCREW, BUTT, SOCK, .25-20X.62, SS BO
19	6	962273	SCREW, PAN, #4-40 X .88, ZINC
20	6	980682	WASHER, FLAT, #4, ZINC
21	6	W385D	NUT, NYLOCK, #4-40, ZINC
22	1	920012	NUT, NYLOCK, 5/16-18, ZINC
23	1	911653	SWITCH, ROUND, ON – MOM
24	1	875124	LABEL CONTROL 22GAL DISK
25	1	911649	SWITCH, ROCKER, AUTO ON-OFF
26	1	911661	METER, HOUR, DIGITAL
27	2	911664	POTENTIOMETER ASSY, 5K
28	1	852401	CABLE, LIFT, CLEVIS
29	1	920038	NUT, HEX, .31-24, SS
30	1	911645	HARNESS, CHARGER, POST
31	2	980033	WASHER, FLAT, #6, SS
32	2	855001	KNOB, ADJUST, .25 BORE
33	4	962264	SCREW, BUTTON, SOCKET, .25 X 1.75, SS

ITEM	QTY	PART NUMBER	DESCRIPTION
34	2	962455	SCREW, TRUSS, .25-20 X 1.0
35	2	W132D	SCREW, PAN, #6-32 X 1.0, ZINC
36	1	920013	NUT, #10-32, ZINC
37	1	850806	BRACKET, PLUG
38	4	980029	WASHER, LOCK, STAR, EXTERNAL
39	1	856608	PLATE, MOUNTING
40	1	911674	HARNESS, POWER, 24 INCH
41	1	911677	HARNESS, SIGNAL, 24 INCH
42	1	962279	SCREW, SOCKET CAP, .31X1.0, SS
43	2	W243D	WASHER, FLAT, 5/16, SS
44	1	855115	LABEL BATTERYSHIELD WITH QR CODE
45	1	872413	CONTROLLER FLOW WATER
46	1	911722	HARNESS SOLUTION FLOW S-SERIES
47	1	980003	WASHER, FLAT, .38
48	1	878208	SPACER PLASTIC #10 X .25 THICK
49	1	920001	NUT, NYLOCK, #10-32, ZINC
50	1	W401D	WASHER, FLAT, #10

S-28 & S-32 DISK CONTROLS

(SEE ADDITIONAL DIAGRAM FOR MODELS EQUIPPED WITH BATTERYSHIELD® OR CHEMICAL INJECTION)

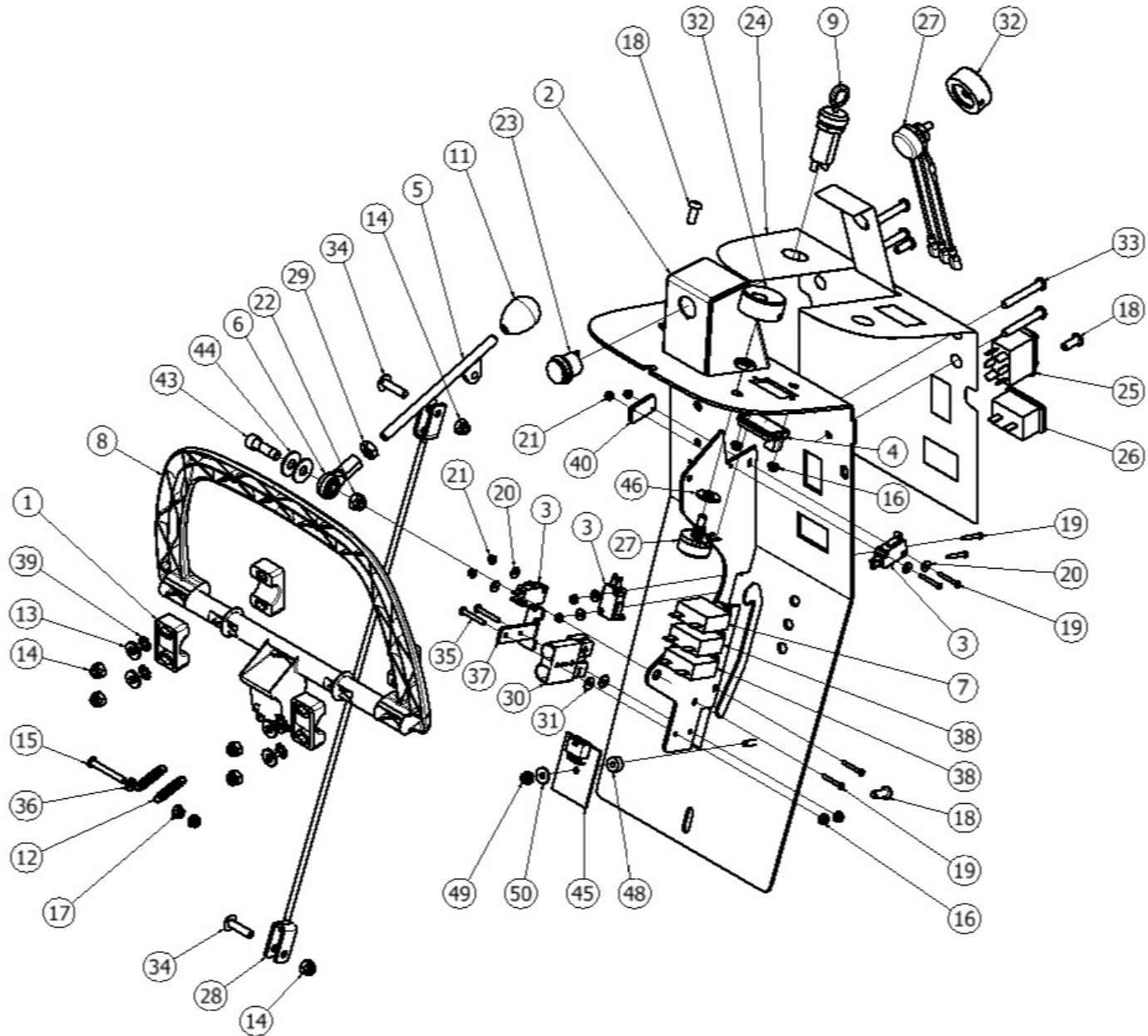

S-28 & S-32 DISK CONTROLS

(SEE ADDITIONAL DIAGRAM FOR MODELS EQUIPPED WITH BATTERYSHIELD® OR CHEMICAL INJECTION)

ITEM	QTY	PART NUMBER	DESCRIPTION
1	4	855601	MOUNT, BEARING, PLASTIC
2	1	877101	PANEL, CONTROLS
3	3	911646	SWITCH, SNAP, WITH ROLLER
4	1	911621	METER, BATTERY
5	1	855106	LEVER, LIFT, SQUEEGEE
6	1	902050	BEARING, ROD END, .31-24
7	1	911622	CIRCUIT BREAKER, 30 AMPS
8	1	851301	BAIL, MOLDED
9	1	911647	SWITCH, KEY
10	1	855012	KEY REPLMNT SCRUB 2-SET FOR 911647
11	1	855004	KNOB, OVAL, .31-18
12	2	858302	SPRING, EXTENSION
13	4	W104D	WASHER, FLAT, .25
14	6	920011	NUT, NYLOCK, 1/4-20, ZINC
15	1	962146	SCREW, PAN, #10-32 X 1.5, FULL, ZINC
16	4	920034	NUT, NYLOCK, #6-32, SS
17	2	920666	NUT, NYLOCK, #10-32, SS
18	4	962263	SCREW, BUTT, SOCK, .25-20X.62, SS BO
19	6	962273	SCREW, PAN, #4-40 X .88, ZINC
20	6	980682	WASHER, FLAT, #4, ZINC
21	6	W385D	NUT, NYLOCK, #4-40, ZINC
22	1	920012	NUT, NYLOCK, 5/16-18, ZINC
23	1	911653	SWITCH, ROUND, ON – MOM
24	1	875124	LABEL CONTROL 22GAL DISK
25	1	911649	SWITCH, ROCKER, AUTO ON-OFF
26	1	911661	METER, HOUR, DIGITAL
27	2	911664	POTENTIOMETER ASSY, 5K
28	1	852401	CABLE, LIFT, CLEVIS
29	1	920038	NUT, HEX, .31-24, SS
30	1	911645	HARNESS, CHARGER, POST
31	2	980033	WASHER, FLAT, #6, SS
32	2	855001	KNOB, ADJUST, .25 BORE
33	4	962264	SCREW, BUTTON, SOCKET, .25 X 1.75, SS

ITEM	QTY	PART NUMBER	DESCRIPTION
34	2	962455	SCREW, TRUSS, .25-20 X 1.0
35	2	W132D	SCREW, PAN, #6-32 X 1.0, ZINC
36	1	920013	NUT, #10-32, ZINC
37	1	850806	BRACKET, PLUG
38	2	911681	BREAKER, CIRCUIT, 35 AMPS
39	4	980029	WASHER, LOCK, STAR, EXTERNAL
40	1	856608	PLATE, MOUNTING
41	1	911675	HARNESS, POWER, 28 & 32 INCH
42	1	911678	HARNESS, SIGNAL, 28 & 32 INCH
43	1	962279	SCREW, SOCKET CAP, .31X1.0, SS
44	2	W243D	WASHER, FLAT, 5/16, SS
45	1	872413	CONTROLLER FLOW WATER
46	1	980003	WASHER, FLAT, .38
47	1	911722	HARNESS SOLUTION FLOW S-SERIES
48	1	878208	SPACER PLASTIC #10 X .25 THICK
49	1	920001	NUT, NYLOCK, #10-32, ZINC
50	1	W401D	WASHER, FLAT, #10

S-28 ORBITAL CONTROLS

(SEE ADDITIONAL DIAGRAM FOR MODELS EQUIPPED WITH BATTERYSHIELD® OR CHEMICAL INJECTION)

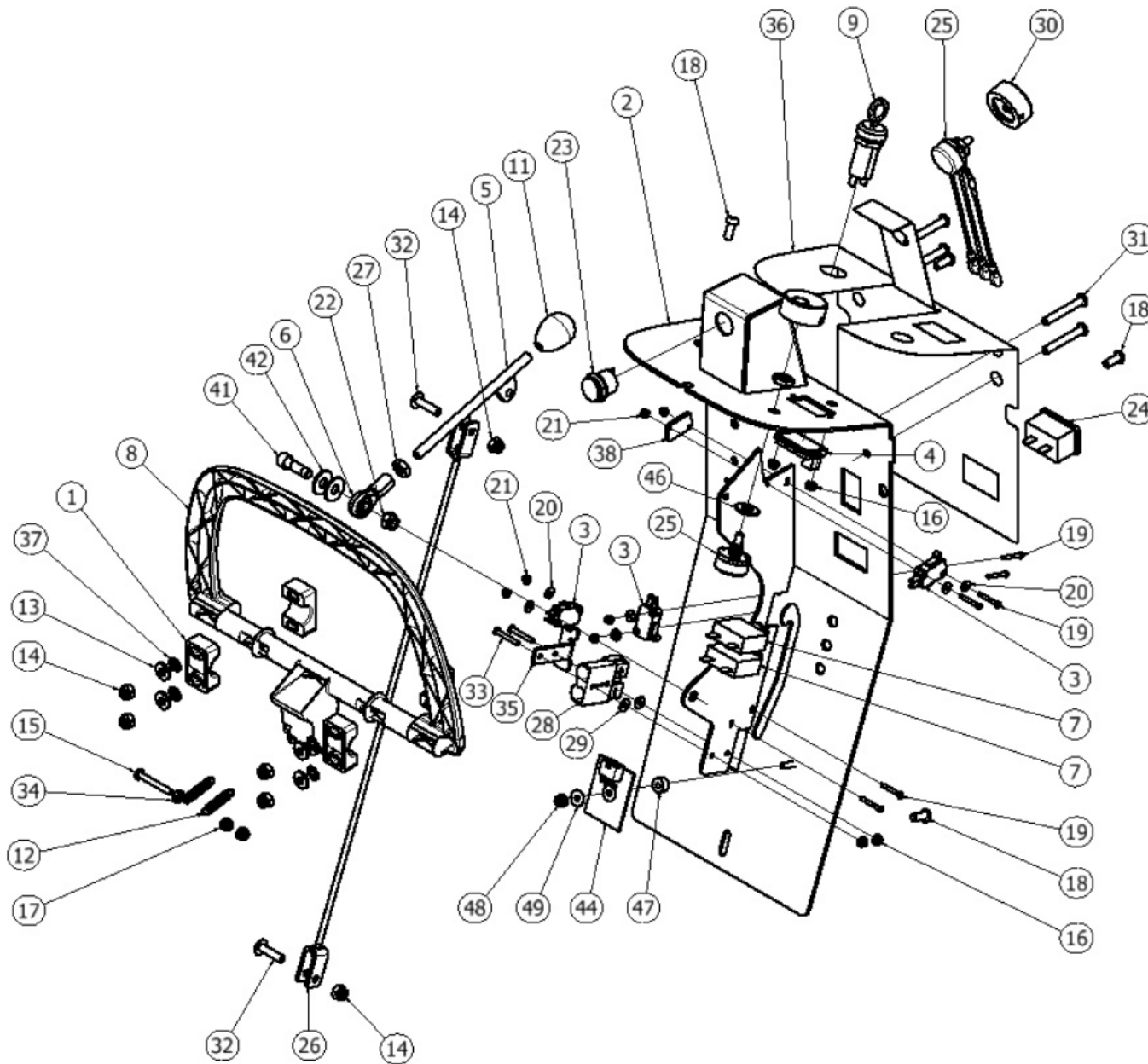

S-28 ORBITAL CONTROLS

(SEE ADDITIONAL DIAGRAM FOR MODELS EQUIPPED WITH BATTERYSHIELD® OR CHEMICAL INJECTION)

ITEM	QTY	PART NUMBER	DESCRIPTION
1	4	855601	MOUNT, BEARING, PLASTIC
2	1	877101	PANEL, CONTROLS
3	3	911646	SWITCH, SNAP, WITH ROLLER
4	1	911621	METER, BATTERY
5	1	855106	LEVER, LIFT, SQUEEGEE
6	1	902050	BEARING, ROD END, .31-24
7	2	911622	CIRCUIT BREAKER, 30 AMPS
8	1	851301	BAIL, MOLDED
9	1	911647	SWITCH, KEY
10	1	855012	KEY REPLMNT SCRUB 2-SET FOR 911647
11	1	855004	KNOB, OVAL, .31-18
12	2	858302	SPRING, EXTENSION
13	4	W104D	WASHER, FLAT, .25
14	6	920011	NUT, NYLOCK, 1/4-20, ZINC
15	1	962146	SCREW, PAN, #10-32 X 1.5, FULL, ZINC
16	4	920034	NUT, NYLOCK, #6-32, SS
17	2	920666	NUT, NYLOCK, #10-32, SS
18	4	962263	SCREW, BUTT, SOCK, .25-20X.62, SS BO
19	6	962273	SCREW, PAN, #4-40 X .88, ZINC
20	6	980682	WASHER, FLAT, #4, ZINC
21	6	W385D	NUT, NYLOCK, #4-40, ZINC
22	1	920012	NUT, NYLOCK, 5/16-18, ZINC
23	1	911653	SWITCH, ROUND, ON – MOM
24	1	911661	METER, HOUR, DIGITAL
25	2	911664	POTENTIOMETER ASSY, 5K
26	1	852401	CABLE, LIFT, CLEVIS
27	1	920038	NUT, HEX, .31-24, SS
28	1	911645	HARNESS, CHARGER, POST
29	2	980033	WASHER, FLAT, #6, SS
30	2	855001	KNOB, ADJUST, .25 BORE
31	4	962264	SCREW, BUTTON, SOCKET, .25 X 1.75, SS
32	2	962455	SCREW, TRUSS, .25-20 X 1.0
33	2	W132D	SCREW, PAN, #6-32 X 1.0, ZINC

ITEM	QTY	PART NUMBER	DESCRIPTION
34	1	920013	NUT, #10-32, ZINC
35	1	850806	BRACKET, PLUG
36	1	875125	LABEL CONTROL 22GAL ORB
37	4	980029	WASHER, LOCK, STAR, EXTERNAL
38	1	856608	PLATE, MOUNTING
39	1	911676	HARNESS, POWER, 28 ORBITAL
40	1	911679	HARNESS, SIGNAL, 28 ORBITAL
41	1	962279	SCREW, SOCKET CAP, .31X1.0, SS
42	2	W243D	WASHER, FLAT, 5/16, SS
43	1	855115	LABEL BATTERYSHIELD WITH QR CODE
44	1	872413	CONTROLLER FLOW WATER
45	1	911722	HARNESS SOLUTION FLOW S-SERIES
46	1	980003	WASHER, FLAT, .38
47	1	878208	SPACER PLASTIC #10 X .25 THICK
48	1	920001	NUT, NYLOCK, #10-32, ZINC
49	1	W401D	WASHER, FLAT, #10

OPTIONAL BATTERYSHIELD & CHEMICAL INJECTION CONTROLS

ITEM	QTY	PART NUMBER	DESCRIPTION
1	1	872401	CONTROLLER, DISPENSING
2	2	875001	KNOB, .25 BORE, SMALL
3	1	875104	LABEL, CONTROL, SOLUTION
4	1	875107	LED, RED, 24VDC
5	1	855115	LABEL BATTERYSHIELD WITH QR CODE
6	1	911684	HARNESS, BATTERYSHIELD
7	1	911680	HARNESS, SOLUTION CONTROL
8	1	855012	KEY REPLMNT SCRUB 2-SET FOR 911647

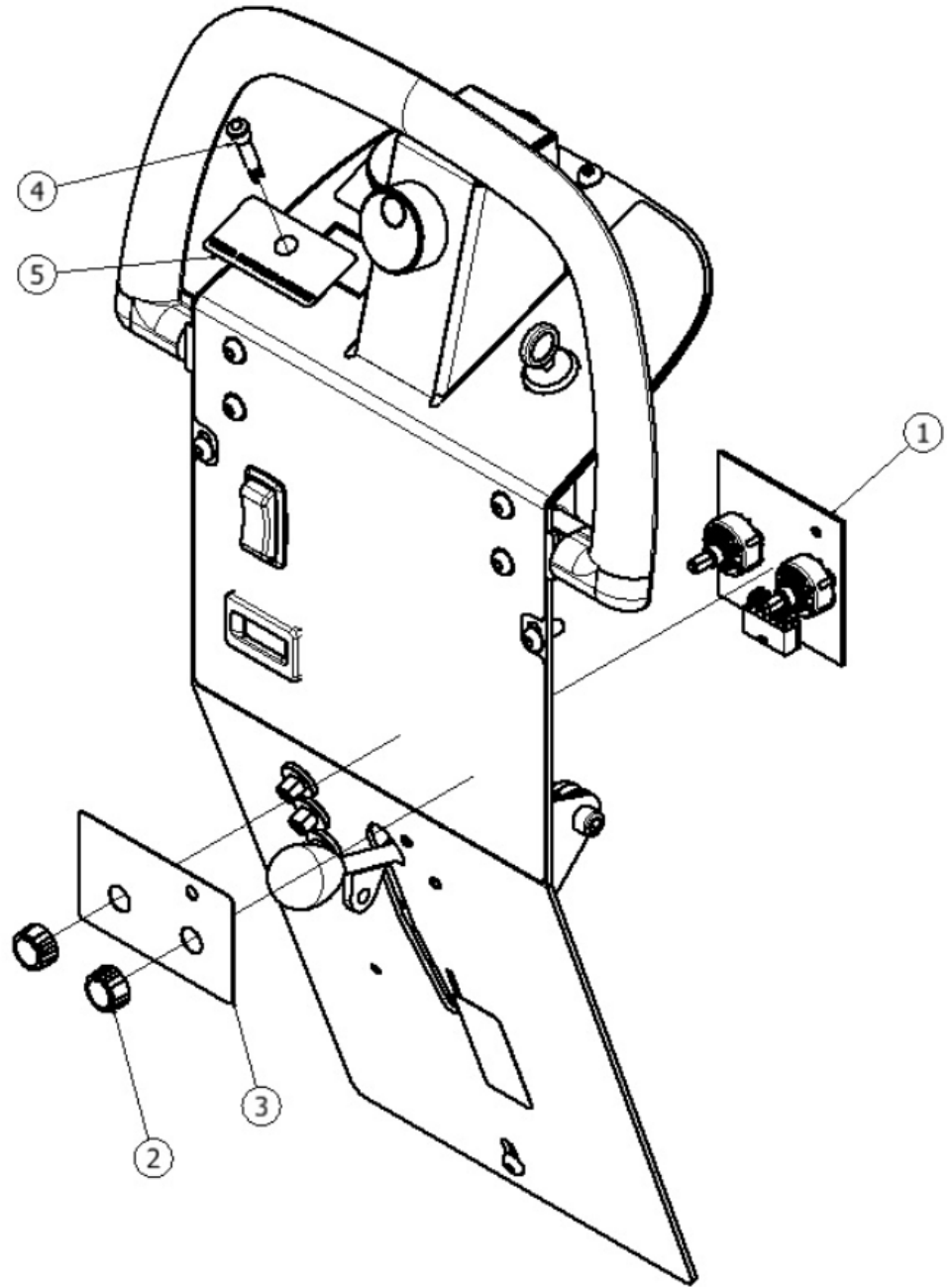

RETURN TO
TABLE OF
CONTENTS

S-24 ELECTRONICS

(SEE ADDITIONAL DIAGRAM FOR MODELS EQUIPPED WITH BATTERYSHIELD® OR CHEMICAL INJECTION)

ITEM	QTY	PART NUMBER	DESCRIPTION
1	1	879101	CONTROLLER, I-DRIVE, MID
2	1	879801	PANEL, ELECTRONICS
3	1	912402	CONTACTOR, 24VDC, 70A
4	2	912401	CONTACTOR, 24V, 100A
5	2	858501	STAND-OFF, INSULATED, .25-20
6	6	W104D	WASHER, FLAT, .25
7	6	980002	WASHER, LOCK, SPLIT, .25
8	4	W169D	SCREW, HEX, .25-20 X .50
9	2	W323D	SCREW, PAN, #6-32 X 1.0, ZINC
10	2	980025	WASHER, SPLIT LOCK, #6, ZINC
11	4	W401D	WASHER, FLAT, #10
12	6	962363	SCREW, PAN, #10-32 X .50, SS
13	6	980022	WASHER, LOCK, SPLIT, #10
14	2	962276	SCREW, SET, .25-20 X 1.25, ZINC, PATCH
15	2	924083	NUT .25-20 FLEX LOCK ZINC

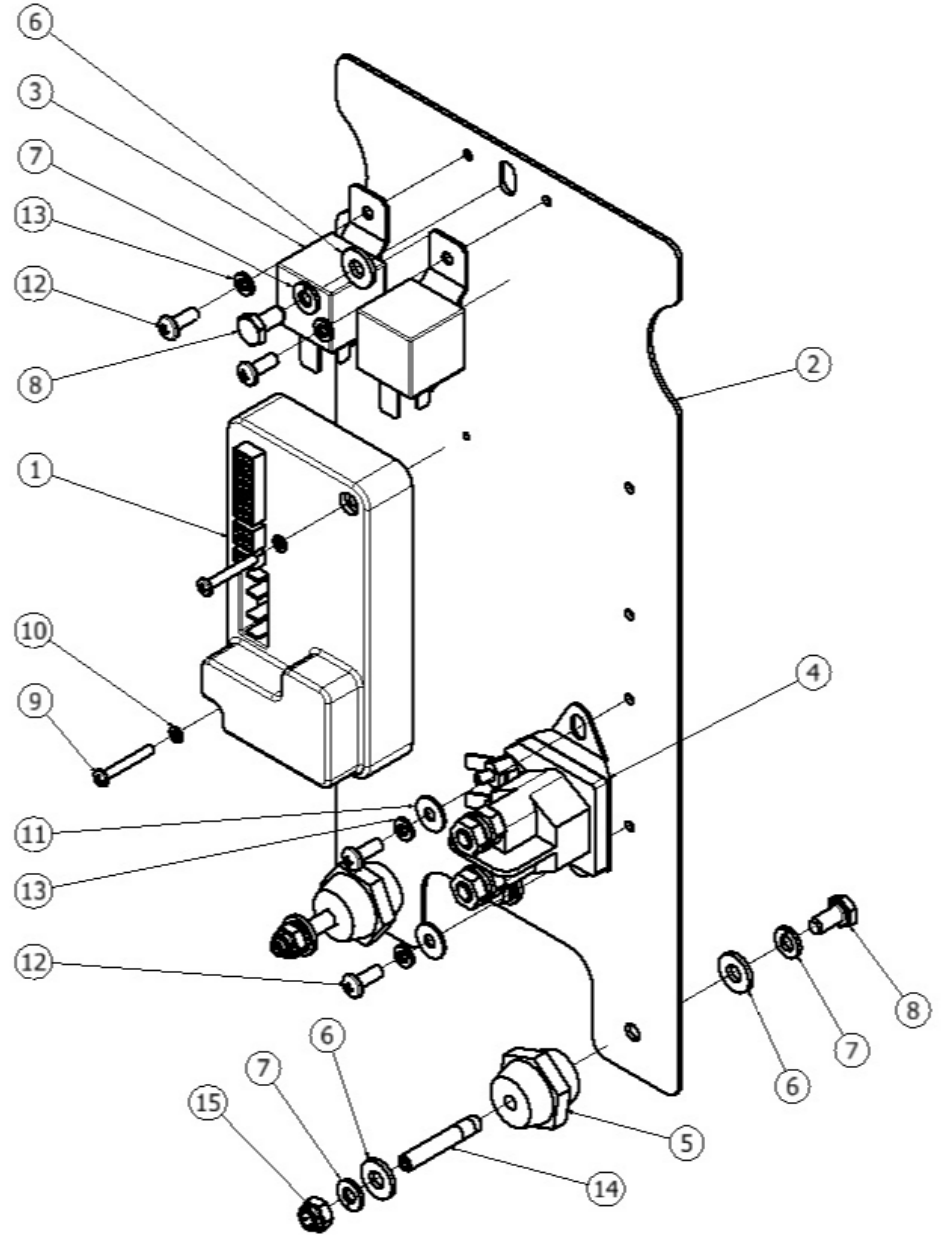

RETURN TO
TABLE OF
CONTENTS

S-28 & S-32 DISK ELECTRONICS

(SEE ADDITIONAL DIAGRAM FOR MODELS EQUIPPED WITH BATTERYSHIELD® OR CHEMICAL INJECTION)

ITEM	QTY	PART NUMBER	DESCRIPTION
1	1	879101	CONTROLLER, I-DRIVE, MID
2	1	879801	PANEL, ELECTRONICS
3	1	912402	CONTACTOR, 24VDC, 70A
4	2	912401	CONTACTOR, 24V, 100A
5	2	858501	STAND-OFF, INSULATED, .25-20
6	6	W104D	WASHER, FLAT, .25
7	6	980002	WASHER, LOCK, SPLIT, .25
8	4	W169D	SCREW, HEX, .25-20 X .50
9	2	W323D	SCREW, PAN, #6-32 X 1.0, ZINC
10	2	980025	WASHER, SPLIT LOCK, #6, ZINC
11	4	W401D	WASHER, FLAT, #10
12	6	962363	SCREW, PAN, #10-32 X .50, SS
13	6	980022	WASHER, LOCK, SPLIT, #10
14	2	962276	SCREW, SET, .25-20 X 1.25, ZINC, PATCH
15	2	924083	NUT, .25-20 FLEX LOCK ZINC

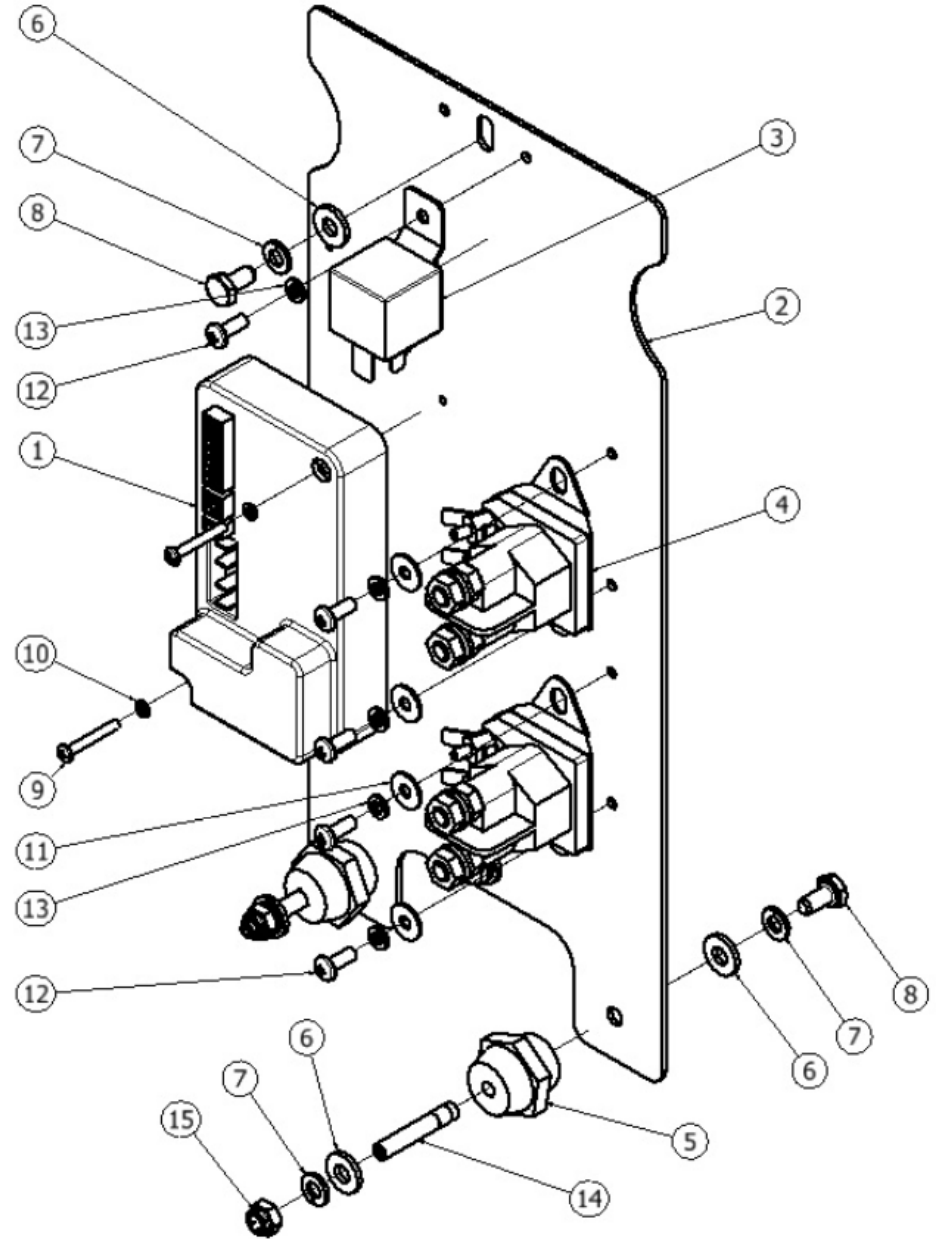

S-28 ORBITAL ELECTRONICS

(SEE ADDITIONAL DIAGRAM FOR MODELS EQUIPPED WITH BATTERYSHIELD® OR CHEMICAL INJECTION)

ITEM	QTY	PART NUMBER	DESCRIPTION
1	1	879101	CONTROLLER, I-DRIVE, MID
2	1	879801	PANEL, ELECTRONICS
3	1	912402	CONTACTOR, 24VDC, 70A
4	2	912401	CONTACTOR, 24V, 100A
5	2	858501	STAND-OFF, INSULATED, .25-20
6	6	W104D	WASHER, FLAT, .25
7	6	980002	WASHER, LOCK, SPLIT, .25
8	4	W169D	SCREW, HEX, .25-20 X .50
9	2	W323D	SCREW, PAN, #6-32 X 1.0, ZINC
10	2	980025	WASHER, SPLIT LOCK, #6, ZINC
11	4	W401D	WASHER, FLAT, #10
12	6	962363	SCREW, PAN, #10-32 X .50, SS
13	6	980022	WASHER, LOCK, SPLIT, #10
14	2	962276	SCREW, SET, .25-20 X 1.25, ZINC, PATCH
15	2	924083	NUT .25-20 FLEX LOCK ZINC

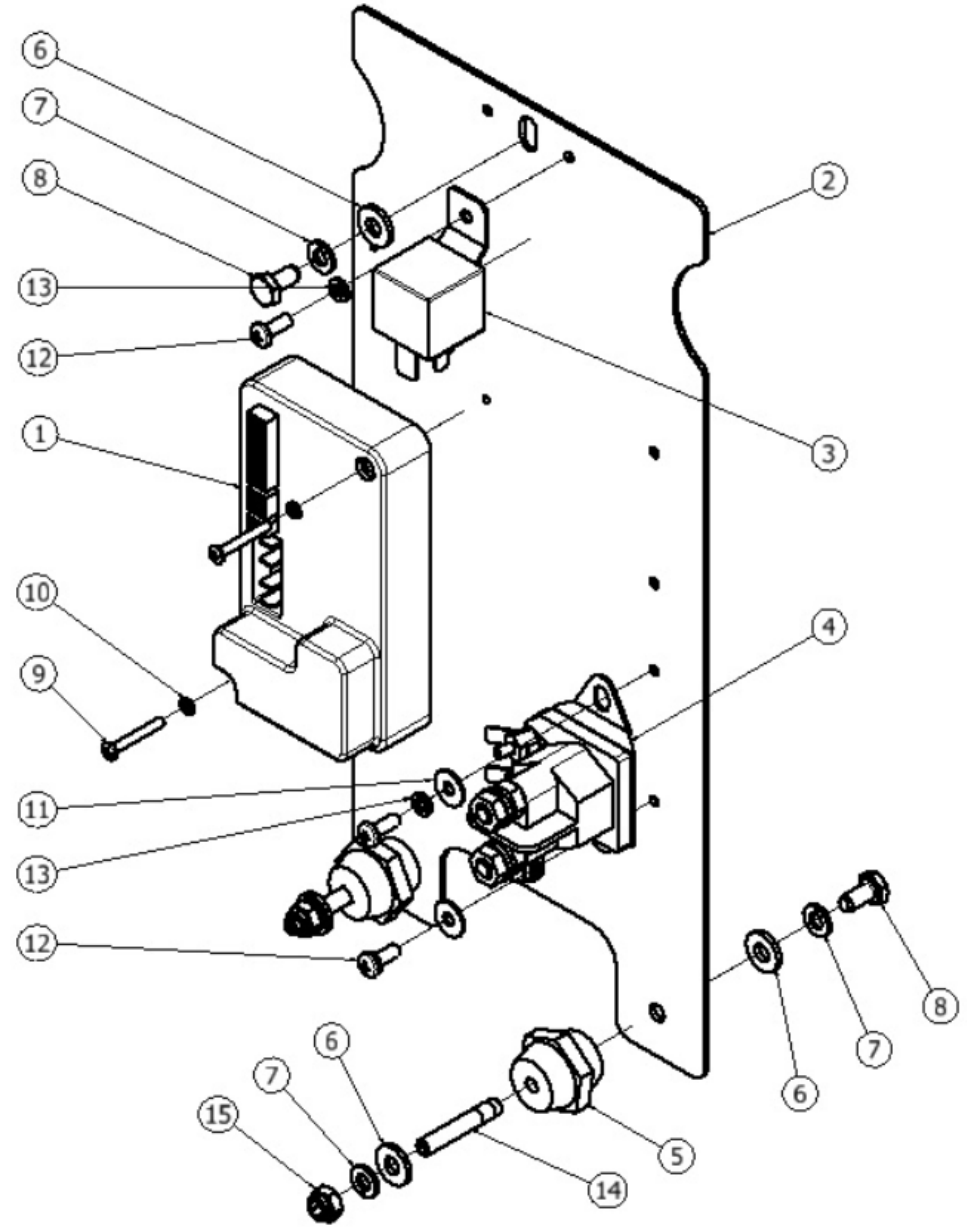

RETURN TO
TABLE OF
CONTENTS

OPTIONAL BATTERSHIELD® ELECTRONICS

ITEM	QTY	PART NUMBER	DESCRIPTION
1	2	980025	WASHER, SPLIT LOCK, #6, ZINC
2	1	911685	RELAY, 24VDC, BATTERYSHIELD
3	2	W315D	SCREW, PAN, #6-32 X .50, BLK
4	2	980033	WASHER, FLAT, #6, SS

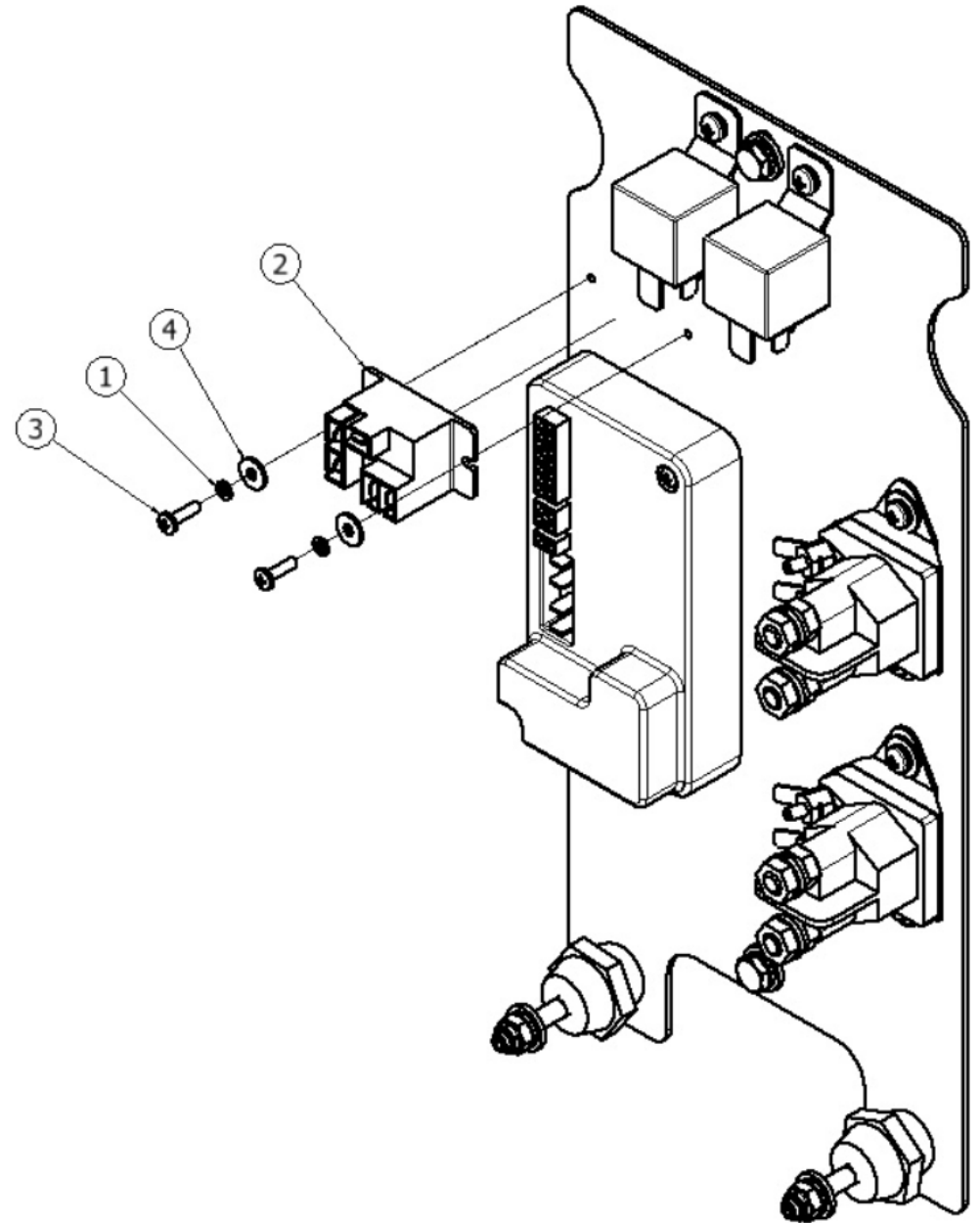

RETURN TO
TABLE OF
CONTENTS

FRAME ASSEMBLY

ITEM	QTY	PART NUMBER	DESCRIPTION
1	1	873201	FRAME, SCRUBBER, 20 TRACT
2	4	W243D	WASHER, FLAT, 5/16, SS
3	8	980094	WASHER, SPLIT LOCK, .31, SS
4	4	962269	SCREW, HEX, .31-18 X .75, SS
5	1	855014	KIT VALVE SCRUBBER REPLMNT
6	1	859402	VALVE SOLENOID 24V NONADJ
7	14	W189D	SCREW, HEX, 1/4-20 X .75, SS, PATCH
8	1	980029	WASHER, LOCK, STAR, EXTERNAL
9	14	920011	NUT, NYLOCK, 1/4-20, ZINC
10	8	W104D	WASHER, FLAT, .25
11	1	852101	CLAMP, WIRE, P-SHAPED
12	1	224130 - 20.0"	TUBING, 1/2"
13	4	S453P	CLAMP, HOSE, WORM
14	1	224130 - 14.0"	TUBING, 1/2"
15	1	843319	FILTER, SCREEN, BOWL
16	1	224130 - 5.12"	TUBING, 1/2"
17	2	850807	BRACKET, RETAINING, TRANS
18	1	879203	TRANSAXLE, 24VDC
19	1	870919	BRUSH KIT REPL FOR TRANSAXLE 879203
20	1	875204	MOTOR REPL FOR TRANSAXLE 879203
21	2	915007	KEY, WOODRUFF, 5MM
22	2	879705	WHEEL, URETHANE, 222MM
23	2	920648	NUT, M12, NYLOCK
24	2	875017	KIT CASTER 4 INCH REPLACEMENT
25	2	877502	RIG CASTER 4INCH WITH AXLE
26	2	879711	WHEEL CASTER 4INCH
27	1	911682	SWITCH, SNAP, BENT LEVER
28	1	856608	PLATE, MOUNTING
29	2	W385D	NUT, NYLOCK, #4-40, ZINC
30	2	962273	SCREW, PAN, #4-40 X .88, ZINC
31	1	873804	GROMMET .50ID .81HOLE .25THK

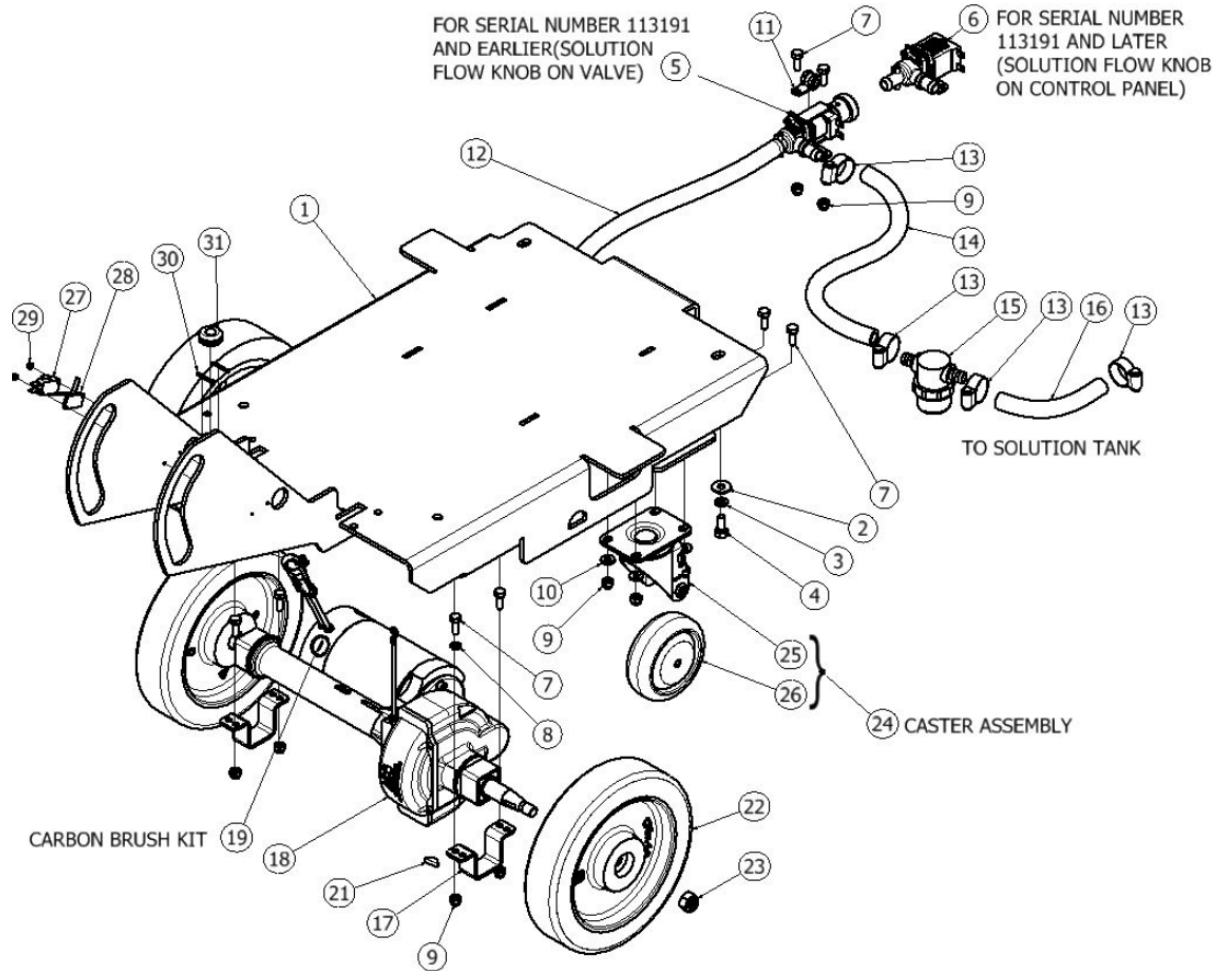

HEAD LIFT ASSEMBLY

ITEM	QTY	PART NUMBER	DESCRIPTION
1	1	870801	BRACKET, LIFT, HEAD
2	6	875601	MOUNT, BEARING, PLASTIC
3	1	875106	LEVER, DOWNPRESSURE
4	1	875105	LABEL, FOOT, GRIP, LARGE
5	1	980108	WASHER, FLAT, .31ID, 1.25OD, .12THK, SS
6	1	980094	WASHER, SPLIT LOCK, .31, SS
7	1	962279	SCREW, SOCKET CAP, .31X1.0, SS
8	4	980612	WASHER, NYL, .50 X 1.25 X .062
9	3	980093	WASHER, WAVE, .50INCH
10	1	878301	SPRING, EXTENSION
11	3	920035	NUT, NYLOCK, .38-16, SS
12	2	871101	BUSHING, FLANGE, .50IN
13	3	962465	SCREW, SHOULDER, .50 X .50
14	1	875002	KNOB, PLASTIC, LARGE
15	6	920012	NUT, NYLOCK, 5/16-18, ZINC
16	6	W243D	WASHER, FLAT, 5/16, SS
17	6	962463	SCREW, HEX, .31-18 X 2.5, SS, FULL THD
18	1	858205	SPACER, RUBBER
19	2	W104D	WASHER, FLAT, .25
20	1	962028	SCREW, HX, .38-24X.75,SS,PTCH
21	1	980009	WASHER, SPLIT LOCK, 3/8, SS
22	1	962221	SCREW, HEX, .25-20 X 1.0, SS
23	1	920037	NUT, THIN JAM, 1/4-20, ZINC
24	1	980002	WASHER, LOCK, SPLIT, .25
25	1	878207	SPACER LIFT ARM
26	1	964256	SCREW .38-16X.88 BUTT SCK ZNC PTCH
27	1	980785	WASHER WAVE 1.0INCH SS

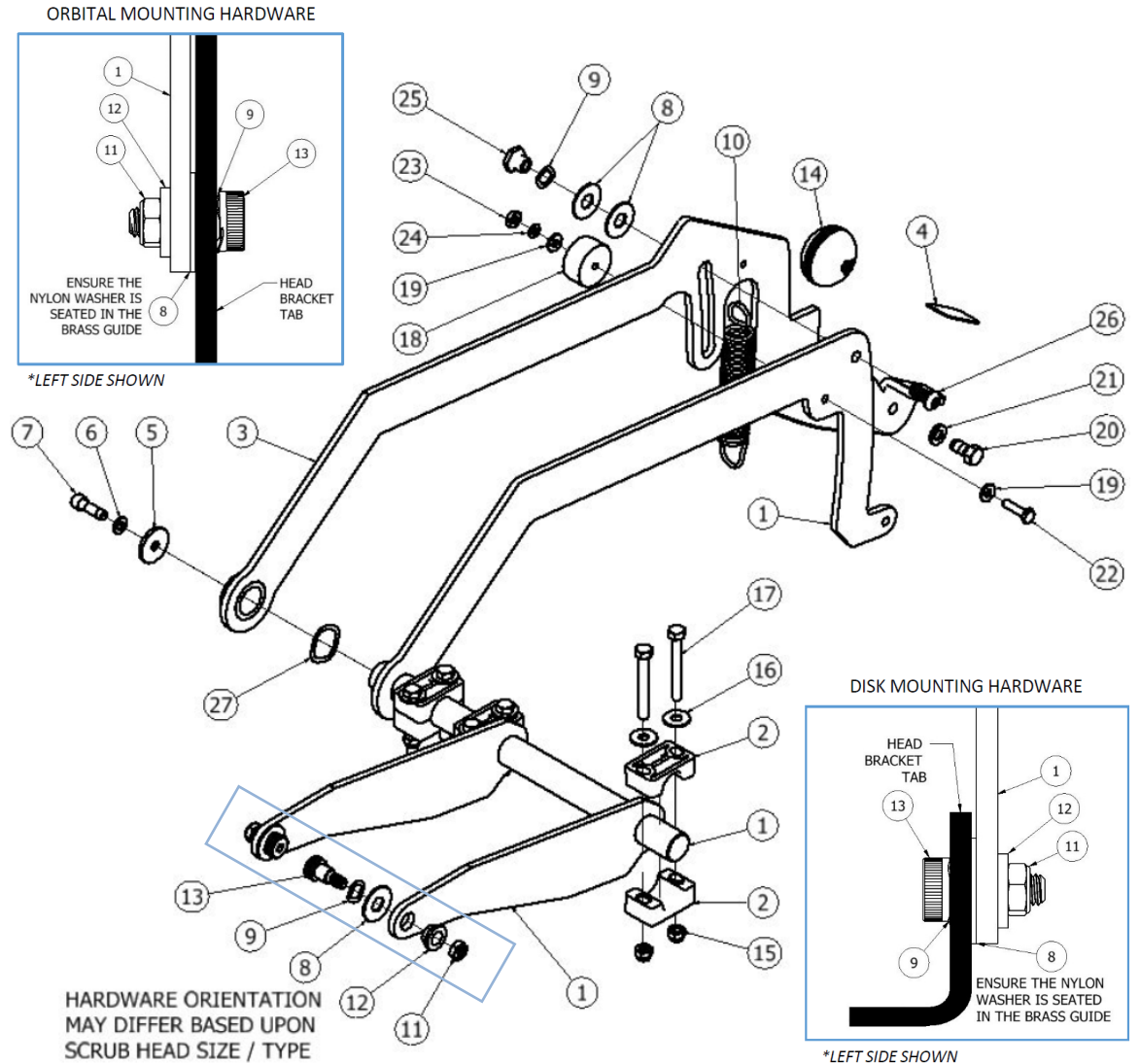

RETURN TO
TABLE OF
CONTENTS

SOLUTION TANK

ITEM	QTY	PART NUMBER	DESCRIPTION
1	1	878601	TANK, SOLUTION, 22 GAL
2	1	870805	BRACKET, SUPPORT, LEVER
3	1	879004	TUBE, SIGHT, REPLACEMENT
4	2	853303	FITTING, STR, BM12, PM08
5	1	W189D	SCREW, HEX, 1/4-20 X .75, SS, PATCH
6	1	920037	NUT, THIN JAM, 1/4-20, ZINC
7	1	962455	SCREW, TRUSS, .25-20 X 1.0
8	4	225670	PAD, WIRE TIE
9	1	S453P	CLAMP, HOSE, WORM
10	4	962271	SCREW, PAN, #10 X .38L, ZINC
11	1	875103	LABEL, INSTRUCTION, BATTERY
12	1	879401	VALVE, SHUT-OFF, BALL
13	1	875011	KIT, STRAINER, PORT, FILL
14	1	872304	COVER, PORT, FILL
15	1	874501	HINGE, TANK, RECOVERY
16	5	962269	SCREW, HEX, .31-18 X .75, SS
17	5	980094	WASHER, SPLIT LOCK, .31, SS
18	5	W243D	WASHER, FLAT, 5/16, SS
19	1	W401D	WASHER, FLAT, #10
20	4	962460	SCREW, #8X.75, PHIL TRUSS SS
21	1	980002	WASHER, LOCK, SPLIT, .25
22	1	870819	BRACKET, RETENTION, HANGER

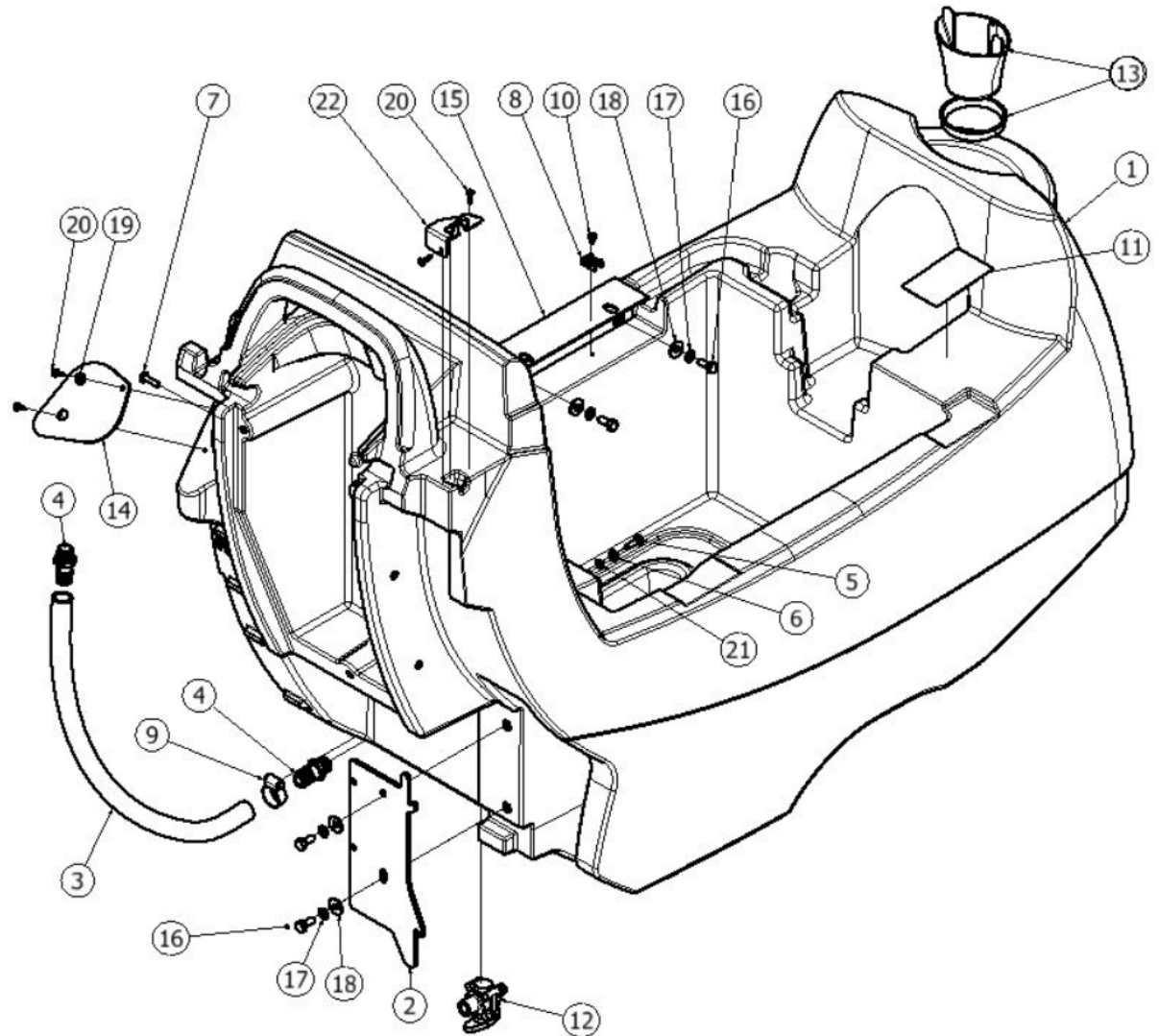

RECOVERY TANK AND VACUUM

ITEM	QTY	PART NUMBER	DESCRIPTION
1	2	223370	FLOAT, SHUTOFF
2	2	853304	FITTING, STR, BM24, PM20
3	1	873401	GASKET, COVER, PRESS-IN
4	1	854103	HOSE, VACUUM, 1.5INCH
5	1	874101	HOSE, SQUEEGEE, 90 CUFF
6	1	874102	HOSE SQUEEGEE MID CHEM RESIST
7	1	852101	CLAMP, WIRE, P-SHAPED
8	4	855603	MOUNT, RUBBER, .25-20
9	2	962462	SCREW, SHOULDER, .38 X 1.75, SS
10	1	878602	TANK, RECOVERY, 22 GAL
11	3	W104D	WASHER, FLAT, .25
12	12	980002	WASHER, LOCK, SPLIT, .25
13	9	920037	NUT, THIN JAM, 1/4-20, ZINC
14	1	870806	BRACKET, MTG, ISOLATOR
15	4	S611A	CLAMP, HOSE, WORM
16	1	854101	HOSE, DRAIN, CAPPED
17	1	851501	CAP HOSE DRAIN - REPL FOR 854101
18	1	854104	HOSE DRAIN CAPPED CHEM RESIST
19	1	872412	CABLE RETENTION MID LONG
20	4	W189D	SCREW, HEX, 1/4-20 X .75, SS, PATCH
21	8	964224	SCREW, PAN, #10 X .5, SELF TAPPING
22	1	853308	FITTING, MODIFIED
23	1	872301	COVER, TANK, RECOVERY
24	1	879201	TRAY, DEBRIS
25	1	877007	PUCK, BROMINE (4-PACK)
26	1	873304	FILTER, HEPA, MID
27	1	879202	TRAY, PUCK
28	2	875202	MOTOR, VACUUM, 24VDC, 3-STAGE
29	2	980106	WASHER, FLAT, .25ID, 1.0OD, .12THK, SS
30	3	962269	SCREW, HEX, .31-18 X .75, SS
31	3	W243D	WASHER, FLAT, 5/16, SS

ITEM	QTY	PART NUMBER	DESCRIPTION
32	3	980094	WASHER, SPLIT LOCK, .31, SS
33	1	875110	LABEL, INSTRUCT, BROMINE
34	1	872303	COVER, MTG, VACUUM
35	1	873314	GASKET, FOAM, VACUUM
36	1	853305	FOAM, NOISE, VACUUM
37	1	874501	HINGE, TANK, RECOVERY
38	2	856803	PLUG HOLE 1 INCH BLACK
39	1	873315	FOAM BARRIER NOISE
40	1	858506	STRAP SUPPORT HOSE

AVAILABLE VACUUM MOTOR KIT - #875023

ITEM	DESCRIPTION	QTY
877802	SHEET INSTR MID-SCRUBBER VAC MTR REPL	1
873314	GASKET, FOAM, VACUUM	1
875202	MTR, VAC, 24VDC, 3STG - KIT 875023 AVAIL	1
873315	FOAM BARRIER NOISE MID	1
853305	FOAM, NOISE, VACUUM	1

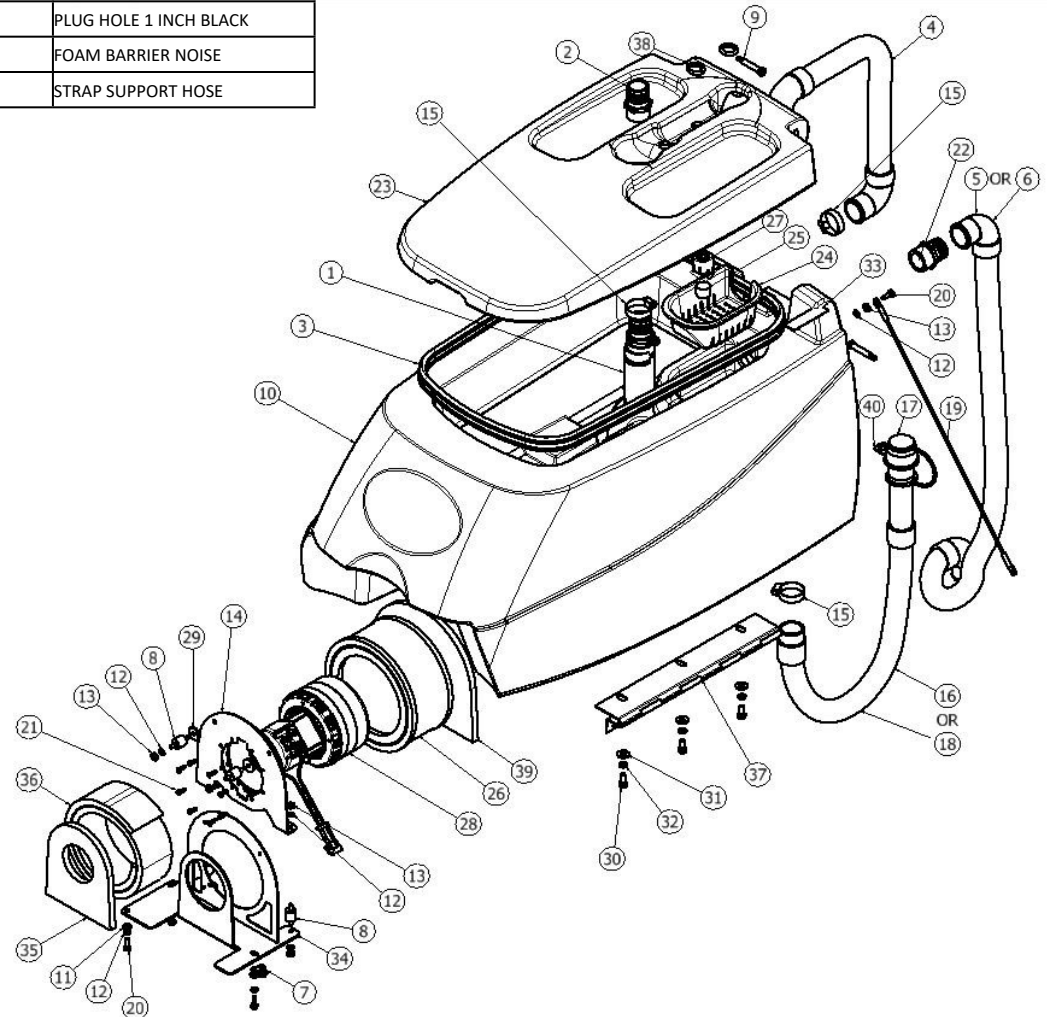

PAGE INTENTIONALLY BLANK

OPTIONAL CHEMICAL INJECTION

ITEM	QTY	PART NUMBER	DESCRIPTION
1	1	877002	PUMP, 24VDC, SOLENOID, EMX08
2	1	870810	BRACKET, HEAT SINK
3	1	870811	BRACKET, MTG, HEAT SINK
4	1	S764P2	FILTER, STRAINER
5	1	871501	CAP, 38MM, WITH HOLE
6	1	879402	VALVE, CHECK, .188 X .50 BARB
7	1	873308	FITTING, TEE, 0.50 INCH
8	2	853301	FITTING, REDUCER, BM08, BM04
9	2	980002	WASHER, LOCK, SPLIT, .25
10	3	W189D	SCREW, HEX, 1/4-20 X .75, SS, PATCH
11	2	962363	SCREW, PAN, #10-32 X .50, SS
12	2	980022	WASHER, LOCK, SPLIT, #10
13	1	879003 - 42.0"	TUBING, 3/16"
14	1	879003 - 10.0"	TUBING, 3/16"
15	1	224130 - 1.62"	TUBING, 1/2"
16	1	224130 - 3.38"	TUBING, 1/2"
17	1	877005	PUMP, GEAR, 24VDC
18	1	872001	CLAMP, P-SHAPED, 1.5 DIA
19	1	224130	TUBING, 1/2"
20	1	224130	TUBING, 1/2"
21	1	920011	NUT, NYLOCK, 1/4-20, ZINC
22	2	224130	TUBING, 1/2"
23	3	872002	CLAMP, HOSE, .31, WIRE
24	1	224130	TUBING, 1/2"
25	2	980107	WASHER, FLAT, .31ID, 1.0OD, .12THK, SS
26	2	S453P	CLAMP, HOSE, WORM
27	4	872003	CLAMP, HOSE, .38, WIRE

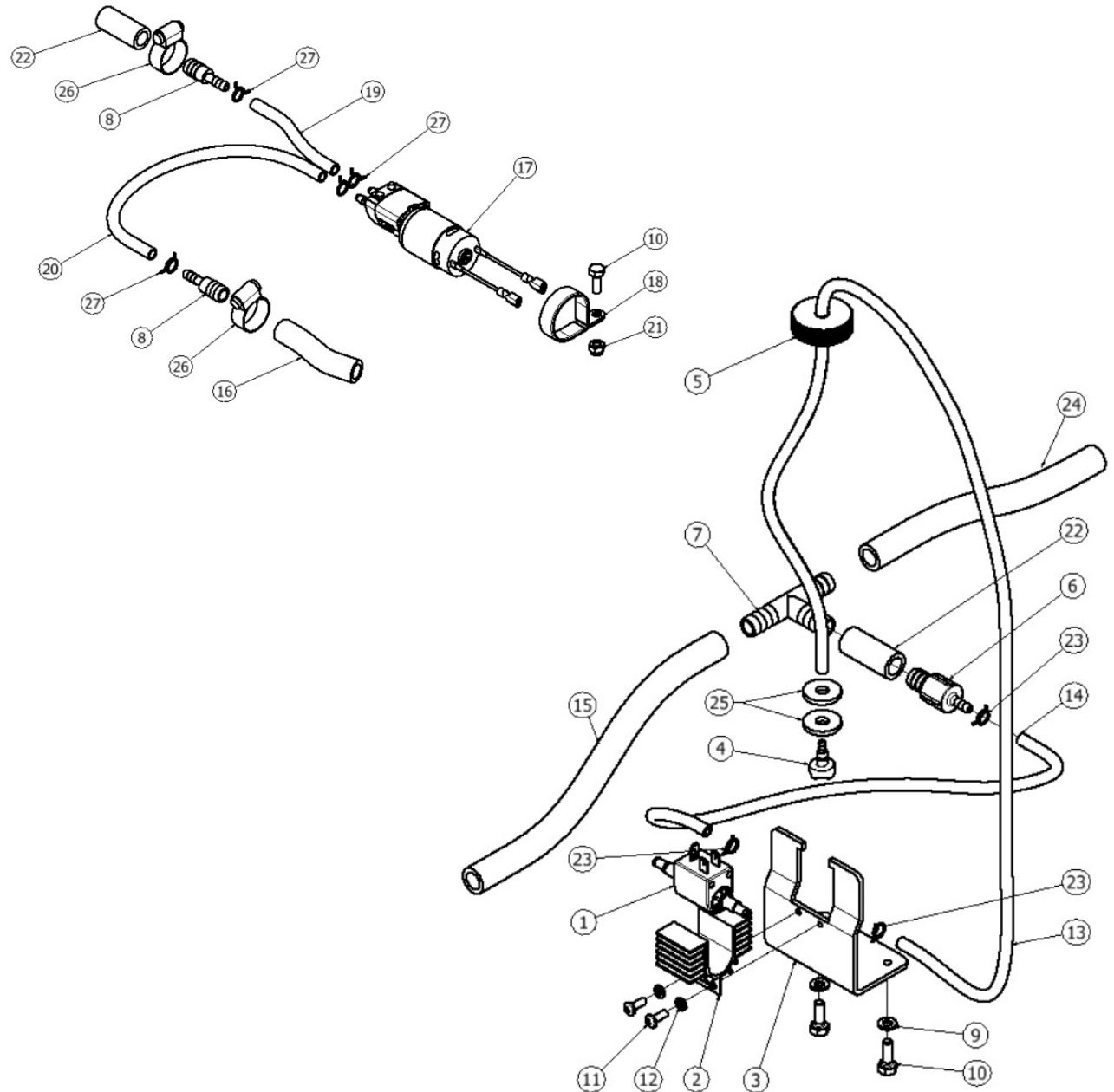

RETURN TO
TABLE OF
CONTENTS

35" SQUEEGEE ASSEMBLY

LINATEX: 878526
 URETHANE: 878511

ITEM	QTY	PART NUMBER	DESCRIPTION
1	1	873203	FRAME, SQUEEGEE, 35 INCH
2	1	870701	BLADE, REAR, 35INCH (LINATEX)
2	1	870707	BLADE, REAR, 35INCH (URETHANE)
3	1	870702	BLADE, FRONT, 35INCH (LINATEX)
3	1	870708	BLADE, FRONT, 35INCH (URETHANE)
4	1	877203	RETAINER, REAR, 35 INCH
5	1	877204	RETAINER, FRONT, 35 INCH
6	2	859703	WHEEL, GUIDE
7	3	962465	SCREW, SHOULDER, .50 X .50
8	4	920034	NUT, NYLOCK, #6-32, SS
9	3	920035	NUT, NYLOCK, .38-16, SS
10	2	852002	CLAMP, OVER-CENTER, BAND
11	1	878516	NARROW AISLE SQUEEGEE ASSY, 30INCH WIDE
12	2	980093	WASHER, WAVE, .50INCH

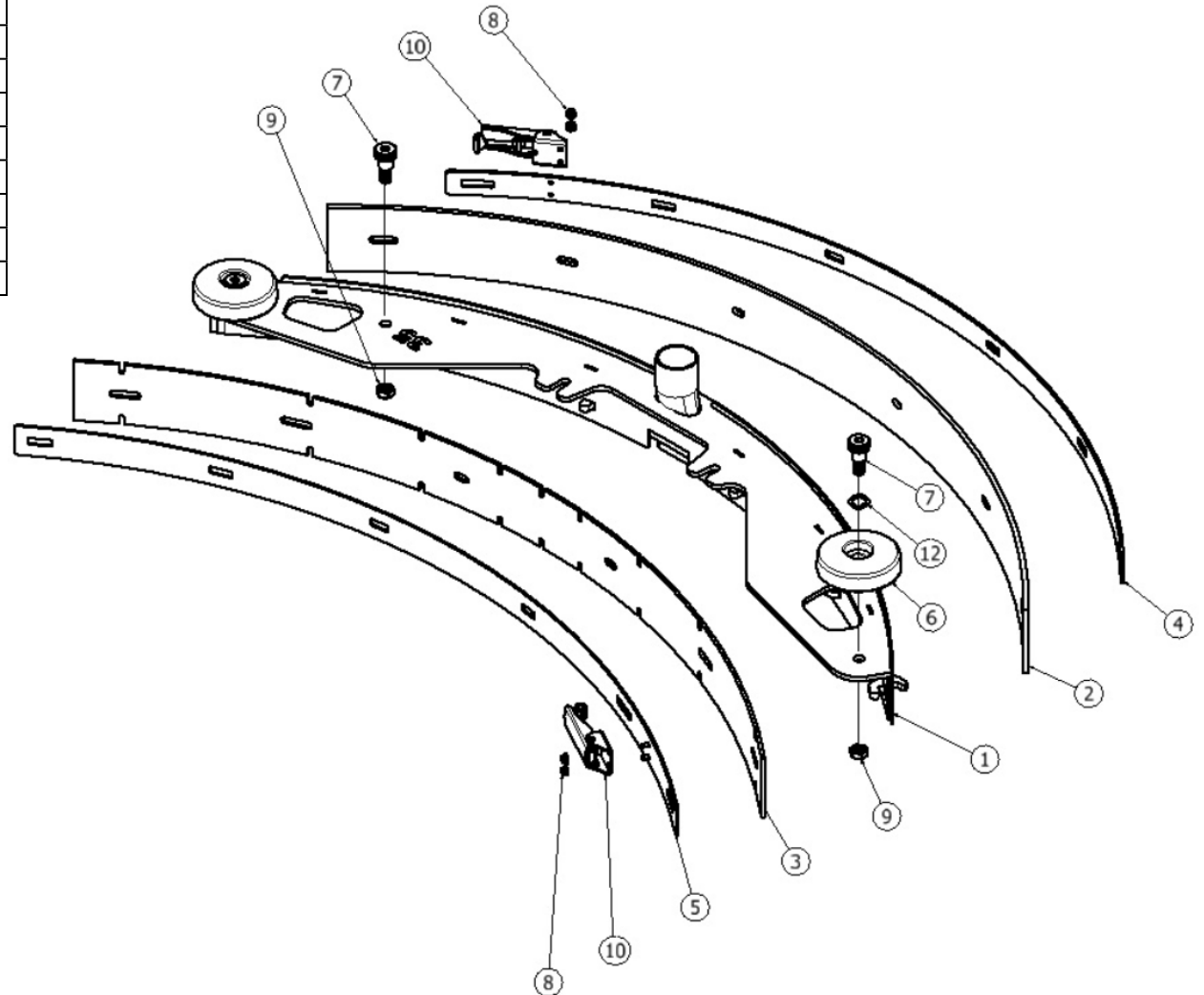
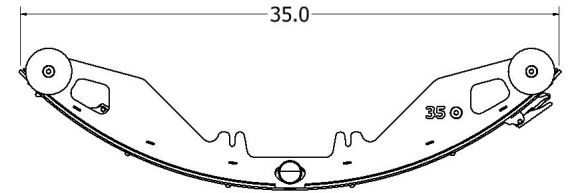

RETURN TO
 TABLE OF
 CONTENTS

40" SQUEEGEE ASSEMBLY

LINATEX: 878527
 URETHANE: 878512

ITEM	QTY	PART NUMBER	DESCRIPTION
1	1	873204	FRAME, SQUEEGEE, 40 INCH
2	1	870703	BLADE, REAR, 40INCH (LINATEX)
2	1	870709	BLADE, REAR, 40INCH (URETHANE)
3	1	870704	BLADE, FRONT, 40INCH (LINATEX)
3	1	870710	BLADE, FRONT, 40INCH (URETHANE)
4	1	877201	RETAINER, REAR, 40 INCH
5	1	877202	RETAINER, FRONT, 40 INCH
6	2	859703	WHEEL, GUIDE
7	3	962465	SCREW, SHOULDER, .50 X .50
8	4	920034	NUT, NYLOCK, #6-32, SS
9	3	920035	NUT, NYLOCK, .38-16, SS
10	2	852002	CLAMP, OVER-CENTER, BAND
11	2	980093	WASHER, WAVE, .50INCH

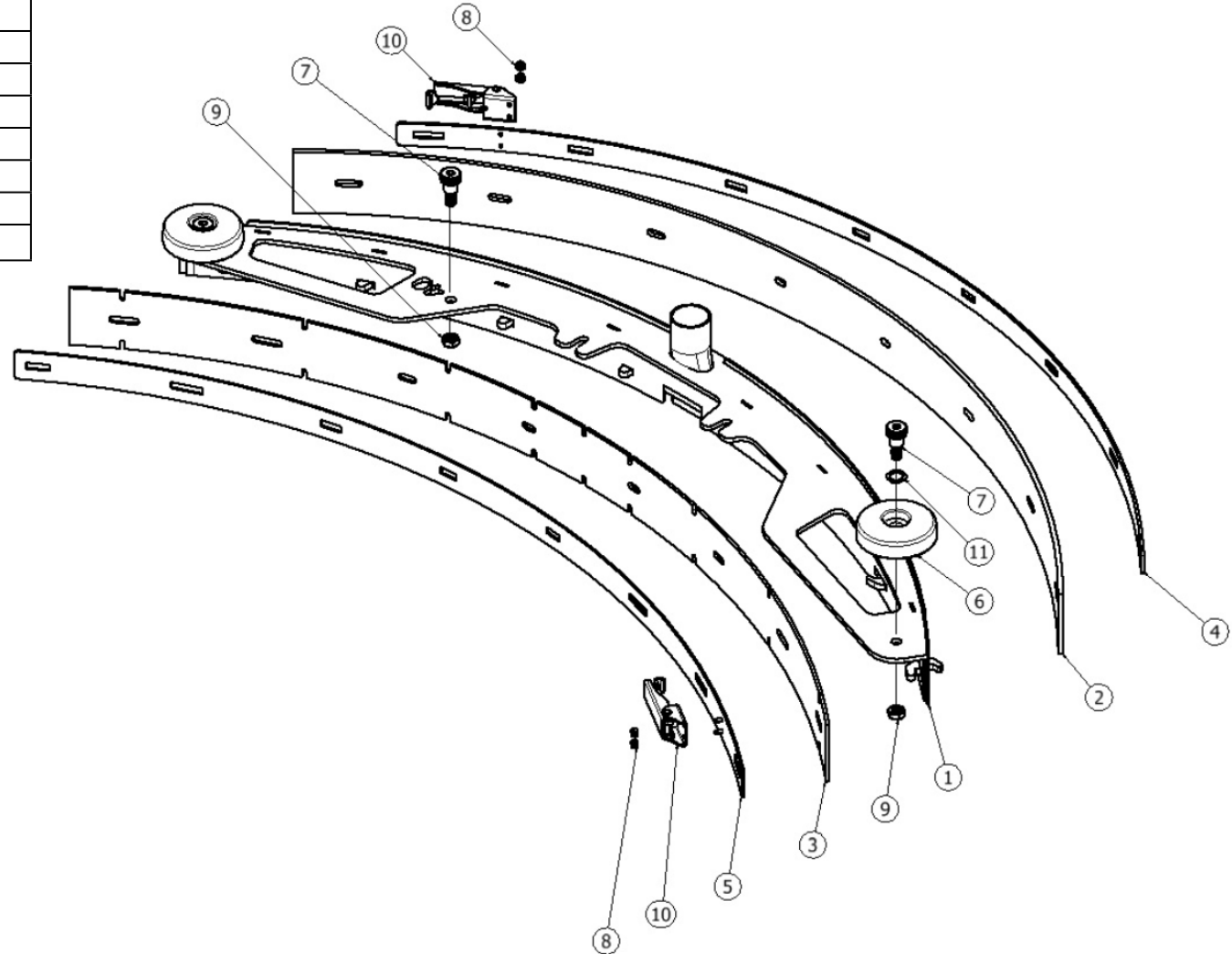
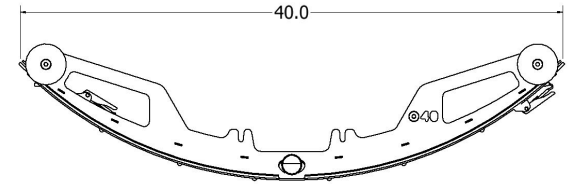

RETURN TO
 TABLE OF
 CONTENTS

45" SQUEEGEE ASSEMBLY

LINATEX: 878528
 URETHANE: 878513

ITEM	QTY	PART NUMBER	DESCRIPTION
1	1	873205	FRAME SQUEEGEE 45 INCH
2	1	870705	BLADE REAR 45 INCH LINATEX
2	1	870711	BLADE REAR 45 INCH URETHANE
3	1	870706	BLADE FRONT 45 INCH LINARD
3	1	870712	BLADE FRONT 45 INCH URETHANE
4	1	877205	RETAINER, REAR, 45 INCH
5	1	877206	RETAINER, FRONT, 45 INCH
6	2	859703	WHEEL, GUIDE
7	3	962465	SCREW, SHOULDER, .50 X .50
8	4	920034	NUT, NYLOCK, #6-32, SS
9	3	920035	NUT, NYLOCK, .38-16, SS
10	2	852002	CLAMP, OVER-CENTER, BAND
11	2	980093	WASHER, WAVE, .50INCH

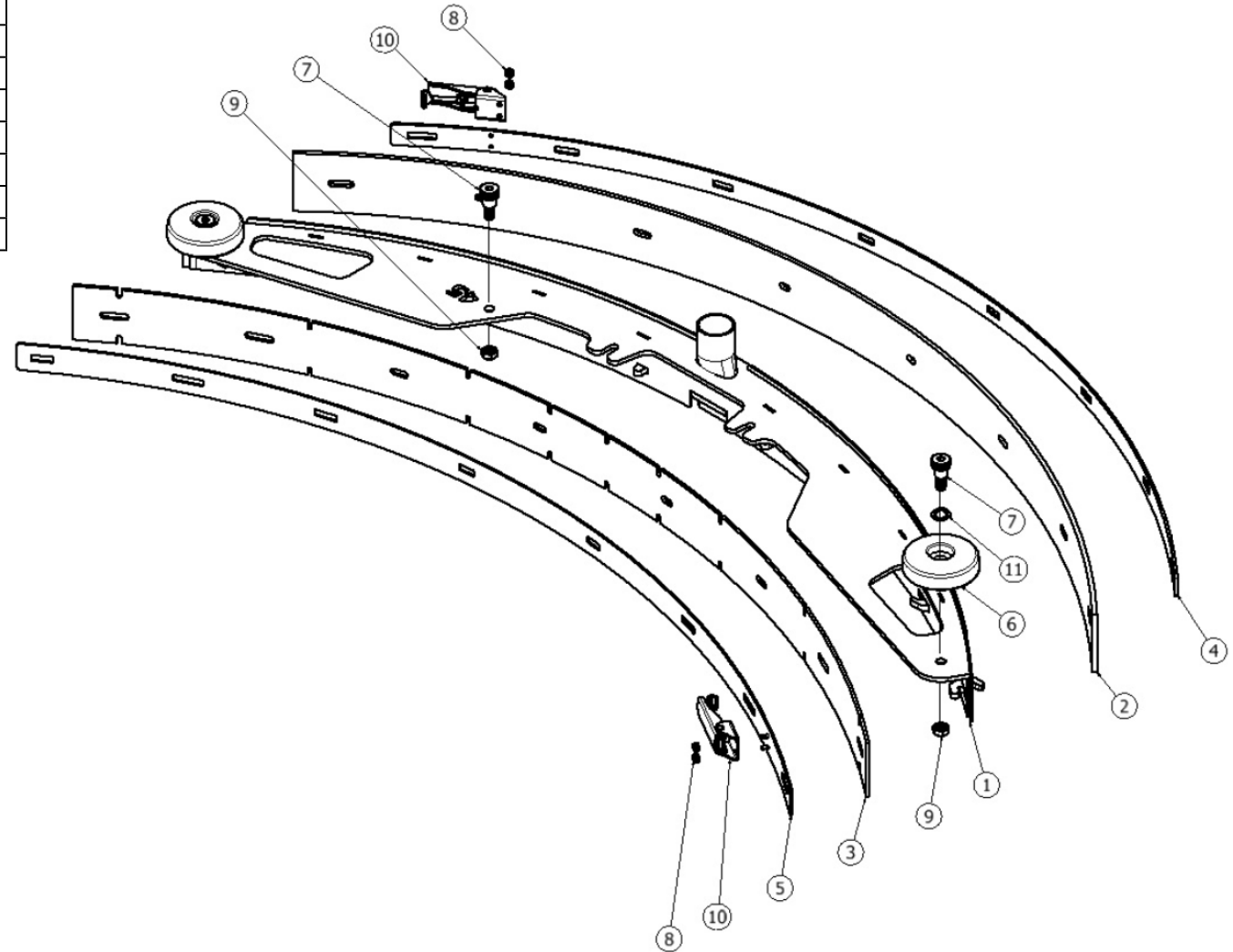
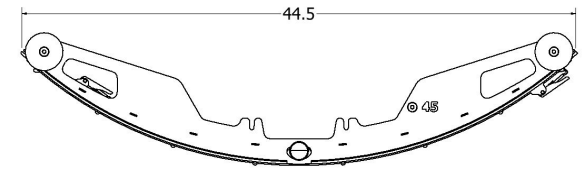

RETURN TO
 TABLE OF
 CONTENTS

SQUEEGEE LINK

ITEM	QTY	PART NUMBER	DESCRIPTION
1	2	849709	WHEEL, 2 OD, .31 ID
2	2	962464	SCREW, BUTTON, .31-18 X 1.25, ZINC
3	1	850501	AXLE, WHEEL, SQUEEGEE
4	1	902051	BEARING, ROD END, .38 FEM
5	1	870802	BRACKET, LINK, SQUEEGEE
6	8	980105	WASHER, PLASTIC, THRUST
7	3	920035	NUT, NYLOCK, .38-16, SS
8	1	962075	SCREW, HEX, 3/8-16 X 1.5, SS
9	1	962028	SCREW, HX, .38-24X.75,SS,PTCH
10	1	870803	BRACKET, SWING, SQUEEGEE
11	1	877501	GUIDE, ROLLER, SQUEEGEE
12	2	962465	SCREW, SHOULDER, .50 X .50
13	2	871101	BUSHING, FLANGE, .50IN
14	1	962270	SCREW, HEX, 5/16-18X1.75,SS
15	1	878504	STRAP, GROUNDING, STATIC
16	1	878204	SPACER, GUIDE, SQUEEGEE
17	1	980003	WASHER, FLAT, .38
18	2	875003	KNOB, THREADED, .31-18 X 1.5
19	1	980107	WASHER, FLAT, .31ID, 1.0OD, .12THK, SS
20	2	877207	RETAINER, FRAME, SQUEEGEE
21	9	920040	NUT, .31-18, NYLOCK, SS, LOW

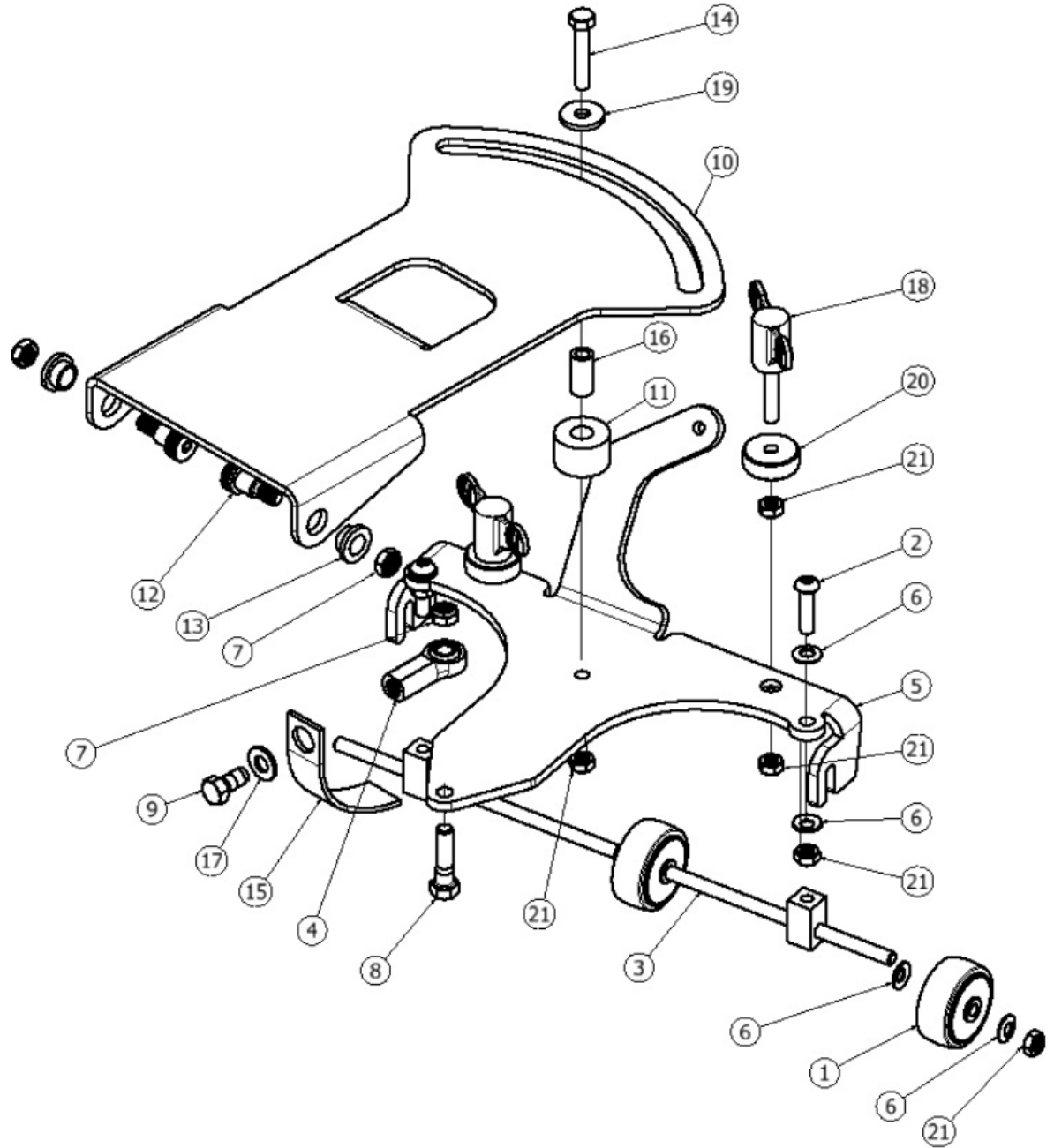

RETURN TO
TABLE OF
CONTENTS

PAGE INTENTIONALLY BLANK

S-24 SCRUB HEAD

(PAGE 2 OF 2)

ITEM	QTY	PART NUMBER	DESCRIPTION
1	2	870902	BRUSH, POLY, 12 INCH
2	2	870908	BRUSH, NYLON, 12 INCH
3	2	870909	BRUSH, GRIT, 12 INCH
4	1	859703	WHEEL, GUIDE
5	1	875019	KIT SKIRT REPLACEMENT (ITEMS 6 - 10)
6	4	962263	SCREW, BUTT, SOCK, .25-20X.62, SS BO
7	4	920665	NUT, NYLOCK, 1/4-20, SS
8	8	W104D	WASHER, FLAT, .25
9	1	872305	SHROUD, HEAD, 24INCH
10	1	858503	SKIRT, BRISTLE
11	13	962274	SCREW, FLAT, SOCK, .25-20X.62, SS, PATCH
12	2	873302	FITTING, TEE, PM02XBM04
13	2	875901	DRIVER, PAD, 12INCH, BRISTLE
14	1	204179 - 16.0"	TUBING, 1/4"
15	1	204179 - 9.75"	TUBING, 1/4"
16	1	204179 - 8.25"	TUBING, 1/4"
17	1	873308	FITTING, TEE, 0.50 INCH
18	2	853301	FITTING, REDUCER, BM08, BM04
19	2	224130 - 1.75"	TUBING, 1/2"
20	1	878205	SPACER, WHEEL, GUIDE
21	1	224130 - 20.0"	TUBING, 1/2"

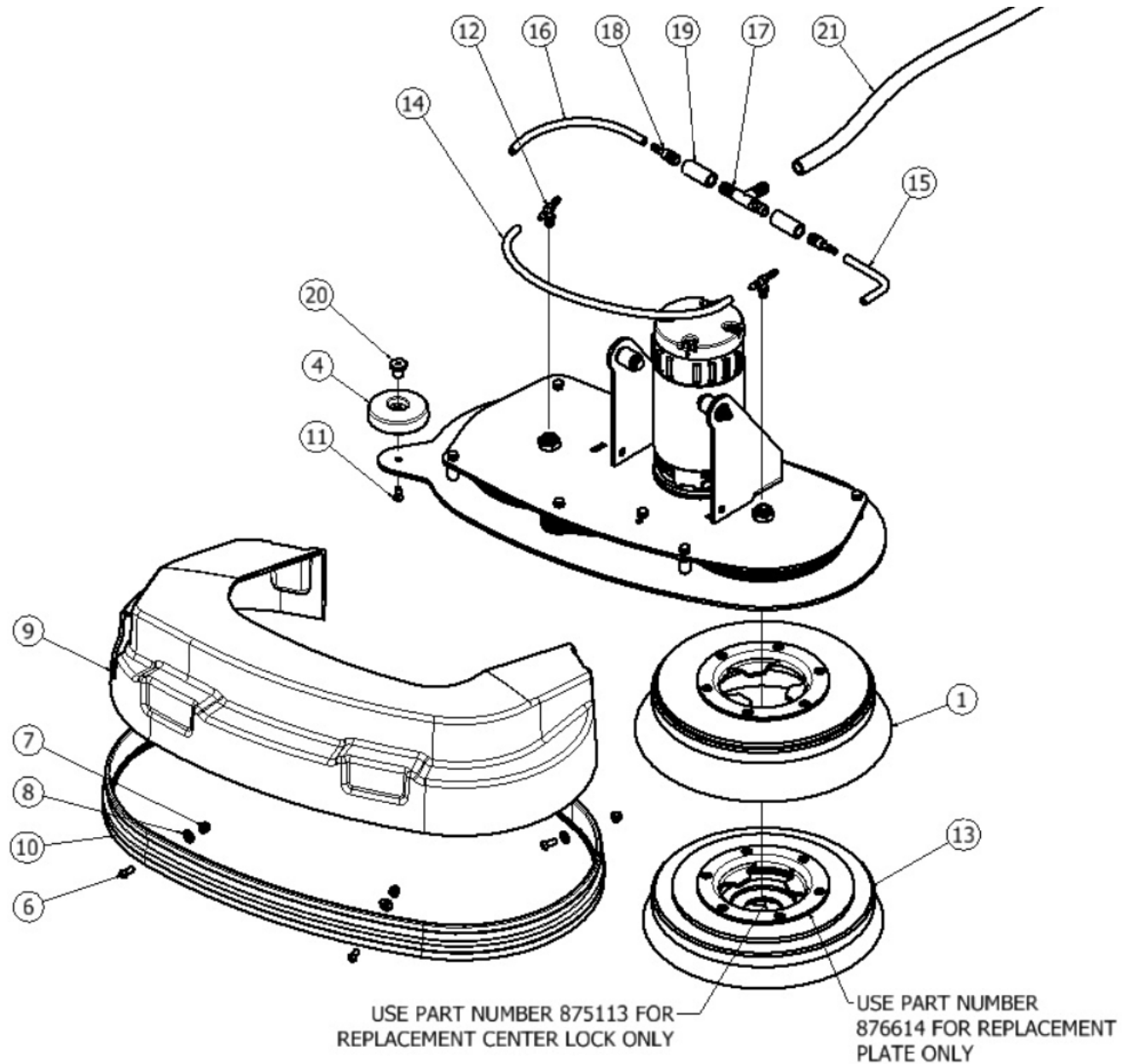

AVAILABLE PADS

PART NUMBER	DESCRIPTION
555901	PAD 12" BLACK STRIP CASE 5
555941	PAD 12" RED SCRUB CASE 5
555951	PAD 12" WHITE POLISH CASE 5

S-24 SCRUB HEAD

(PAGE 1 OF 2)

ITEM	QTY	PART NUMBER	DESCRIPTION
1	1	876602	PLATE, MTG, 24 INCH
2	3	858203	SPACER, WHEEL, GUIDE
3	8	W104D	WASHER, FLAT, .25
4	9	W243D	WASHER, FLAT, 5/16, SS
5	1	853803	GUIDE, DRIVER
6	2	873801	GUIDE, PAD, PLASTIC
7	3	857501	ROLLER, PLASTIC
8	13	962274	SCREW, FLAT, SOCK, .25-20X.62, SS, PATCH
9	3	962270	SCREW, HEX, 5/16-18X1.75,SS
10	3	920012	NUT, NYLOCK, 5/16-18, ZINC
11	1	855204	MOTOR, 24V, 2200 RPM, 1HP
12	1	850906	BRUSH CARBON KIT 4 PC 855204 & 875201
13	1	903046	BELT, V-GROOVE, STRETCH
14	1	876606	PLATE, COVER, 24 INCH
15	2	877701	SHAFT, PULLEY, HEAD
16	6	902035	BEARING, .5 ID, 1.1875 OD
17	3	876901	PULLEY, IDLER
18	3	877302	RING, RETAINING, INT, 1.12 DIA
19	6	878201	SPACER, IDLER
20	3	878202	SPACER, IDLER, PLAIN
21	1	876902	PULLEY, MOTOR, DRIVE
22	1	980108	WASHER, FLAT, .31ID, 1.25OD, .12THK, SS
23	1	915006	KEY, 8MM X 7MM X 28MM
24	4	902053	BEARING, .75 ID, DBL SEAL
25	2	980003	WASHER, FLAT, .38
26	2	878203	SPACER, BEARING
27	1	874306	HUB, PULLEY, MACH GROOVED
28	1	874305	HUB, PULLEY, MACH FLAT
29	1	870807	BRACKET, SUPPORT, HEAD 24
30	4	964008	SCREW, HEX, M6 X 25, SS, PATCH
31	1	964060	SCREW, HEX, M8-1.25 X 20, SS

ITEM	QTY	PART NUMBER	DESCRIPTION
32	2	920039	NUT, .62-18, NYLOCK, LOW
33	1	870814	BRACKET, SUPPORT, 24XM
34	2	920035	NUT, NYLOCK, .38-16, SS
35	1	873802	GUIDE, DRIVER, RH
36	1	878206	SPACER, MOTOR, 24INCH
37	6	W189D	SCREW, HEX, 1/4-20 X .75, SS, PATCH
38	6	980002	WASHER, LOCK, SPLIT, .25
39	2	857009	PLUNGER BALL PRESS-IN

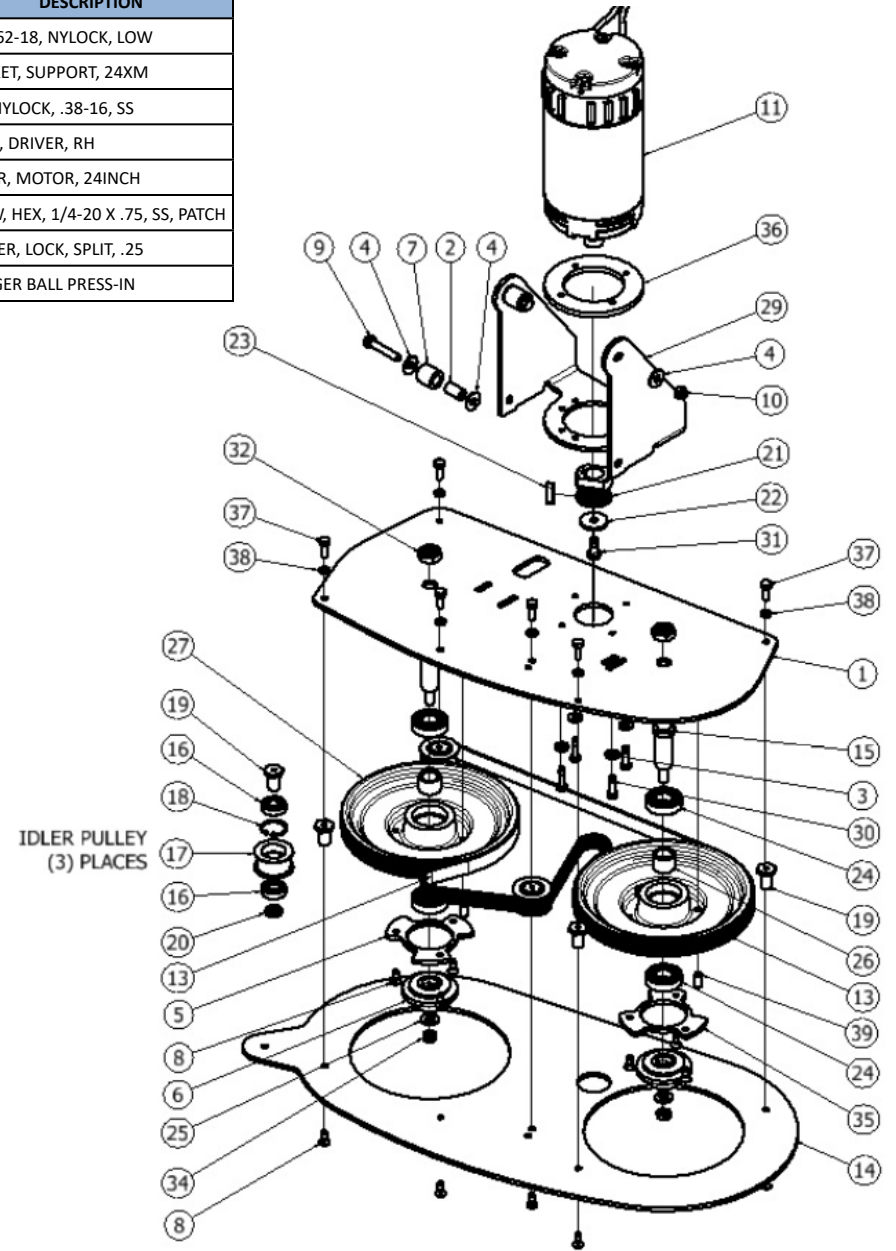

RETURN TO
TABLE OF
CONTENTS

S-28 DISK SCRUB HEAD

*** PRIOR TO SERIAL NUMBER 121567 ***

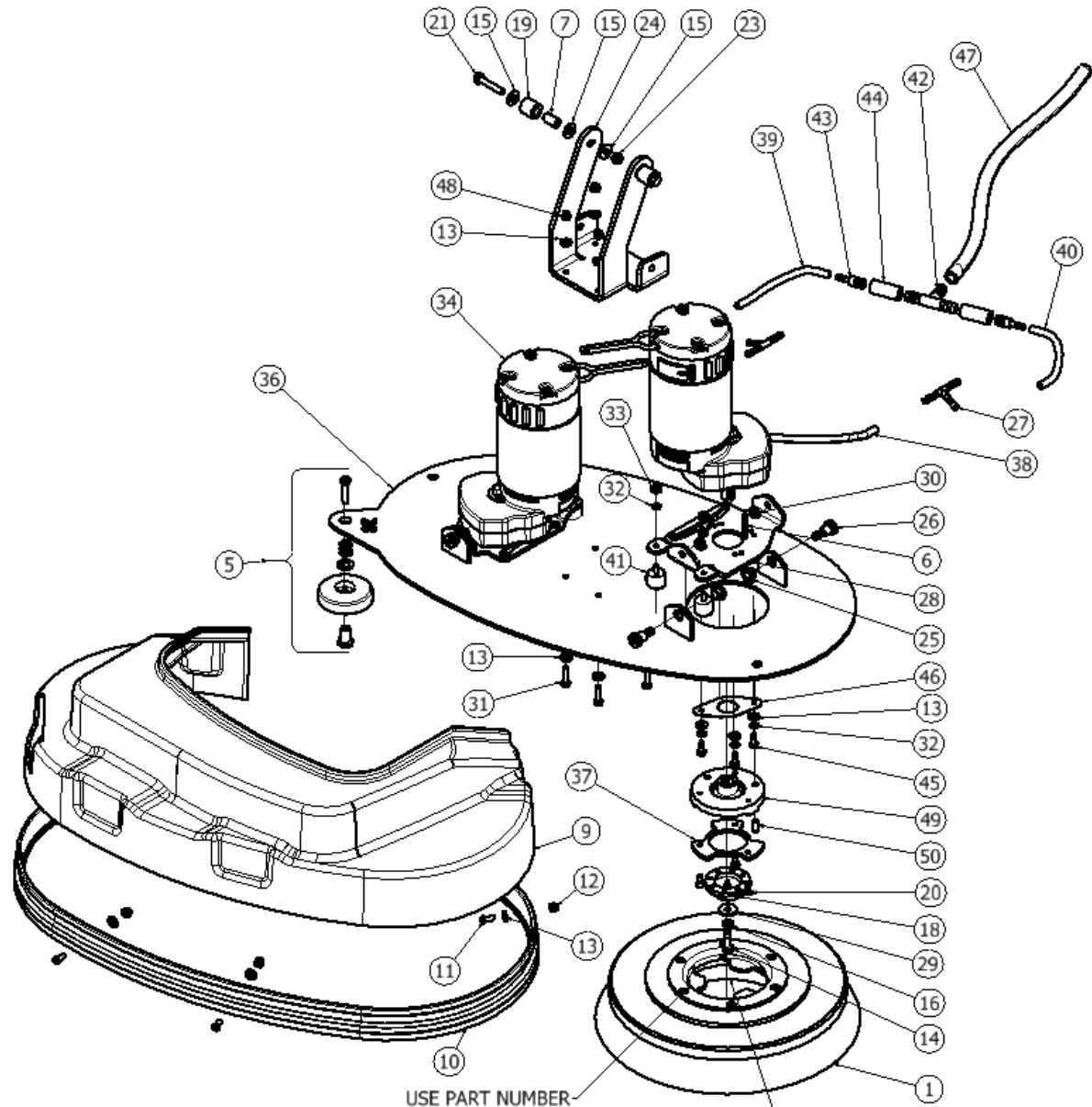

USE PART NUMBER
876614 FOR REPLACEMENT
PLATE ONLY

USE PART NUMBER 875113 FOR
REPLACEMENT CENTER LOCK ONLY

S-28 DISK SCRUB HEAD

*** PRIOR TO SERIAL NUMBER 121567 ***

ITEM	QTY	PART NUMBER	DESCRIPTION
1	2	870901	BRUSH, POLY, 14 INCH
1	2	870904	BRUSH, NYLON, 14 INCH
1	2	870906	BRUSH, GRIT, 14 INCH
1	2	875902	DRIVER, PAD, 14 INCH
5	1	855022	KIT GUIDE WHEEL REPLACEMENT ANIT-RATTLE
6	2	915008	KEY, SQUARE, 5MM X 5 X 40MM
7	3	858203	SPACER, WHEEL, GUIDE
8	1	875020	KIT SHROUD S28 REPLACEMENT (ITEMS 9 - 13)
9	1	872302	SHROUD, HEAD, 28INCH
10	1	878502	SKIRT, BRISTLE
11	4	962263	SCREW, BUTT, SOCK, .25-20X.62, SS BO
12	4	920665	NUT, NYLOCK, 1/4-20, SS
13	20	W104D	WASHER, FLAT, .25
14	2	962466	SCREW, HEX, M8-1.25 X 25, SS, PATCH
15	6	W243D	WASHER, FLAT, 5/16, SS
16	2	980094	WASHER, SPLIT LOCK, .31, SS
17	1	853803	GUIDE, DRIVER
18	2	853804	GUIDE, PAD, PLASTIC
19	2	857501	ROLLER, PLASTIC
20	6	962274	SCREW, FLAT, SOCK, .25-20X.62, SS, PATCH
21	2	962270	SCREW, HEX, 5/16-18X1.75,SS
23	2	920012	NUT, NYLOCK, 5/16-18, ZINC
24	1	870804	BRACKET, SUPPORT, HEAD
25	4	871101	BUSHING, FLANGE, .50IN
26	4	962465	SCREW, SHOULDER, .50 X .50
27	2	873301	FITTING, TEE, .25INCH
28	2	876604	PLATE, MOUNTING, GIMBLE
29	2	980107	WASHER, FLAT, .31ID, 1.0OD, .12THK, SS
30	4	920035	NUT, NYLOCK, .38-16, SS
31	4	962221	SCREW, HEX, .25-20 X 1.0, SS
32	12	980002	WASHER, LOCK, SPLIT, .25
33	4	920037	NUT, THIN JAM, 1/4-20, ZINC
34	2	875203	MOTOR GEAR BRUSH MRP15 SERVICE
35	1	850906	BRUSH CARBON KIT 4 PC 855204 & 875201

ITEM	QTY	PART NUMBER	DESCRIPTION
36	1	876601	PLATE, MTG, 28INCH
37	1	873802	GUIDE, DRIVER, RH
38	1	204179 - 15.2"	TUBING, 1/4"
39	1	204179 - 6.0"	TUBING, 1/4"
40	1	204179 - 5.5"	TUBING, 1/4"
41	4	875603	BUMPER, RUBBER, WITH STUD
42	1	873308	FITTING, TEE, 0.50 INCH
43	2	853301	FITTING, REDUCER, BM08, BM04
44	2	224130 - 1.75"	TUBING, 1/2"
45	8	964448	SCREW, HEX, M6 X 16, SS, PATCH
46	2	870818	BRACKET, RETAINING, SEAL
47	1	224130 - 20.0"	TUBING, 1/2"
48	4	920011	NUT, NYLOCK, 1/4-20, ZINC
49	2	854302	HUB, DRIVER, BRUSH
50	2	857009	PLUNGER BALL PRESS-IN

AVAILABLE PADS

PART NUMBER	DESCRIPTION
555902	PAD 14" BLACK STRIP CASE 5
555942	PAD 14" RED SCRUB CASE 5
555952	PAD 14" WHITE POLISH CASE 5

S-28 DISK SCRUB HEAD

*** AFTER SERIAL NUMBER 121567 ***

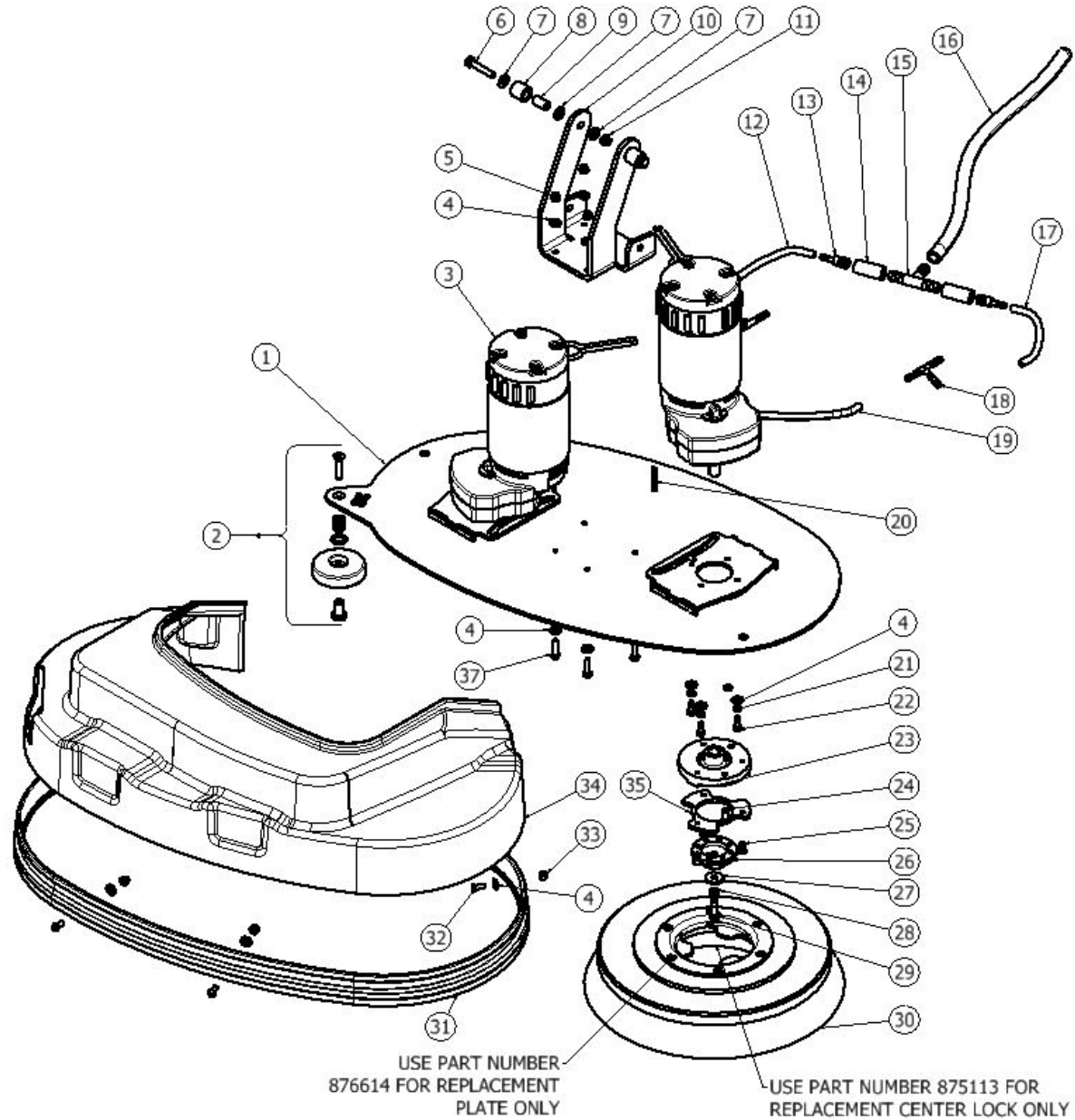

S-28 DISK SCRUB HEAD

*** AFTER SERIAL NUMBER 121567 ***

ITEM	QTY	PART NUMBER	DESCRIPTION
1	1	876612	PLATE, MTG, 28INCH, TORNADO
2	1	855022	KIT WHEEL GUIDE REPLACEMENT
3	2	875203	MOTOR GEAR BRUSH MRP15 SERVICE
4	20	W104D	WASHER, FLAT, .25
5	4	920011	NUT, NYLOCK, 1/4-20, ZINC
6	2	962270	SCREW, HEX, 5/16-18X1.75,SS
7	6	W243D	WASHER, FLAT, 5/16, SS
8	2	857501	ROLLER, PLASTIC
9	2	858203	SPACER, WHEEL, GUIDE
10	1	870804	BRACKET, SUPPORT, HEAD
11	2	920012	NUT, NYLOCK, 5/16-18, ZINC
12	1	204179 - 6.0"	TUBING, 1/4"
13	2	853301	FITTING, REDUCER, BM08, BM04
14	2	224130 - 1.75"	TUBING, 1/2"
15	1	873308	FITTING, TEE, 0.50 INCH
16	1	224130 - 20.0"	TUBING, 1/2"
17	1	204179 - 5.5"	TUBING, 1/4"
18	2	873301	FITTING, TEE, .25INCH
19	1	204179 - 15.2"	TUBING, 1/4"
20	2	915008	KEY, SQUARE, 5MM X 5 X 40MM
21	8	980002	WASHER, LOCK, SPLIT, .25
22	8	964448	SCREW, HEX, M6 X 16, SS, PATCH
23	2	854302	HUB, DRIVER, BRUSH
24	2	857009	PLUNGER BALL PRESS-IN
25	6	962274	SCREW, FLAT, SOCK, .25-20X.62, SS, PATCH
26	2	853804	GUIDE, PAD, PLASTIC
27	2	980107	WASHER, FLAT, .31ID, 1.0OD, .12THK, SS
28	2	980094	WASHER, SPLIT LOCK, .31, SS
29	2	962466	SCREW, HEX, M8-1.25 X 25, SS, PATCH
30	2	870901	BRUSH, POLY, 14 INCH
31	1	878502	SKIRT, BRISTLE

ITEM	QTY	PART NUMBER	DESCRIPTION
32	4	962263	SCREW, BUTT, SOCK, .25-20X.62, SS BO
33	4	920665	NUT, NYLOCK, 1/4-20, SS
34	1	872302	SHROUD, HEAD, 28INCH
35	1	873802	GUIDE, DRIVER, RH
36	1	853803	GUIDE, DRIVER, LH (NOT SHOWN)
37	4	962221	SCREW, HEX, .25-20 X 1.0, SS
38	1	875020	ASSY SHROUD S28 REPLACEMENT (ITEMS 31-34 & 4)
39	1	850906	BRUSH CARBON KIT 4 PC 855204 & 875201

AVAILABLE PADS

PART NUMBER	DESCRIPTION
555902	PAD 14" BLACK STRIP CASE 5
555942	PAD 14" RED SCRUB CASE 5
555952	PAD 14" WHITE POLISH CASE 5
870904	BRUSH NYLON 14"
870906	BRUSH GRIT 14"
875902	DRIVER PAD 14"

S-32 SCRUB HEAD

*** PRIOR TO SERIAL NUMBER 121567 ***

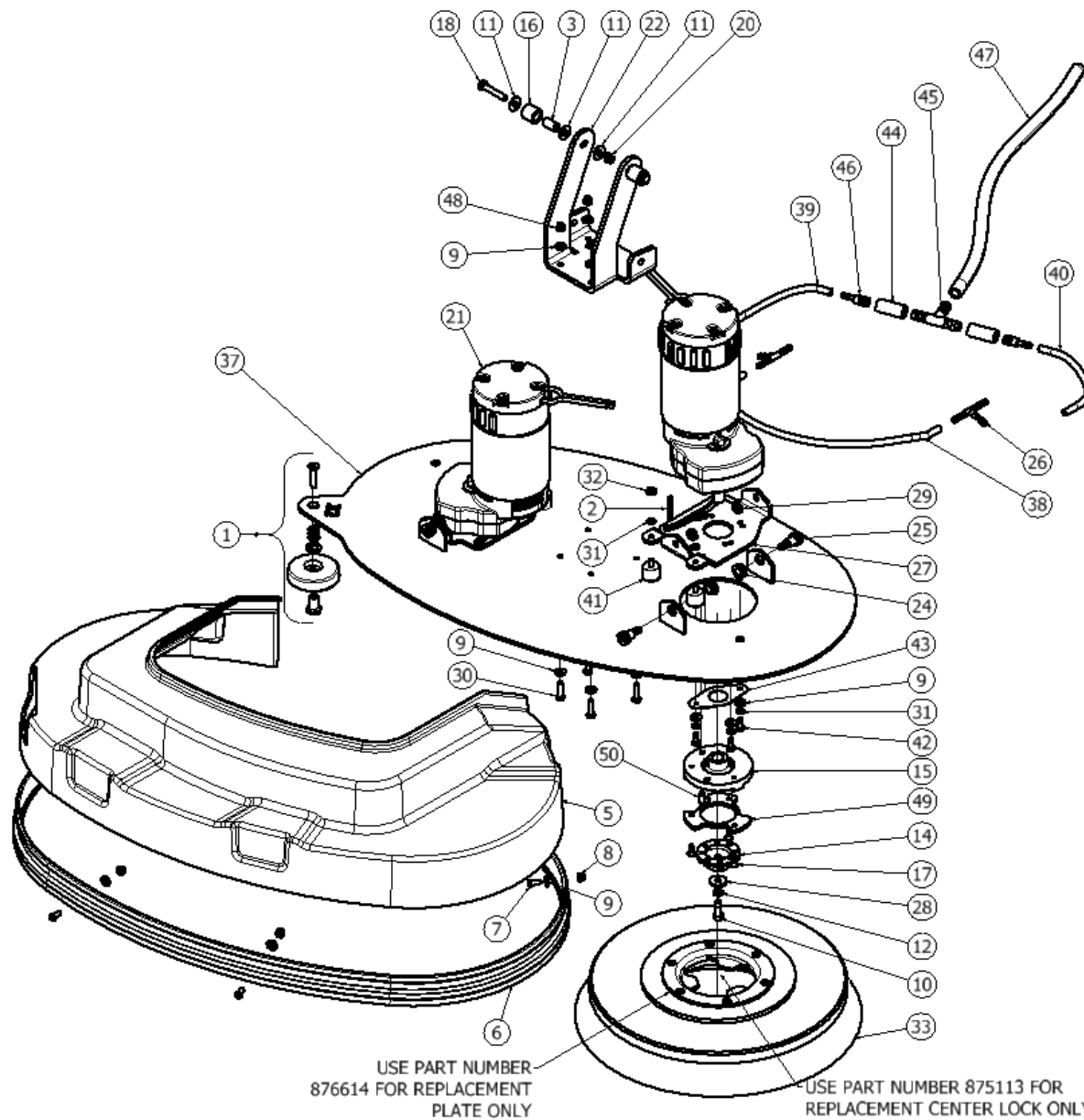

S-32 SCRUB HEAD

*** PRIOR TO SERIAL NUMBER 121567 ***

ITEM	QTY	PART NUMBER	DESCRIPTION
1	1	855022	KIT GUIDE WHEEL RELACEMENT ANTI-RATTLE
2	2	915008	KEY, SQUARE, 5MM X 5 X 40MM
3	2	858203	SPACER, WHEEL, GUIDE
4	1	875021	KIT SHROUD S32 REPLACEMENT (ITEMS 4 - 8)
5	1	872306	SHROUD, HEAD, 32INCH
6	1	878502	SKIRT, BRISTLE
7	4	962263	SCREW, BUTT, SOCK, .25-20X.62, SS BO
8	4	920665	NUT, NYLOCK, 1/4-20, SS
9	20	W104D	WASHER, FLAT, .25
10	2	962466	SCREW, HEX, M8-1.25 X 25, SS, PATCH
11	6	W243D	WASHER, FLAT, 5/16, SS
12	2	980094	WASHER, SPLIT LOCK, .31, SS
13	1	853803	GUIDE, DRIVER
14	2	853804	GUIDE, PAD, PLASTIC
15	2	854302	HUB, DRIVER, BRUSH
16	2	857501	ROLLER, PLASTIC
17	6	962274	SCREW, FLAT, SOCK, .25-20X.62, SS, PATCH
18	2	962270	SCREW, HEX, 5/16-18X1.75,SS
20	2	920012	NUT, NYLOCK, 5/16-18, ZINC
21	2	875203	MOTOR GEAR BRUSH MRP15 SERVICE
22	1	870804	BRACKET, SUPPORT, HEAD
23	1	850906	BRUSH CARBON KIT 4 PC 855204 & 875201
24	4	871101	BUSHING, FLANGE, .50IN
25	4	962465	SCREW, SHOULDER, .50 X .50
26	2	873301	FITTING, TEE, .25INCH
27	2	876604	PLATE, MOUNTING, GIMBLE
28	2	980107	WASHER, FLAT, .31ID, 1.0OD, .12THK, SS
29	4	920035	NUT, NYLOCK, .38-16, SS
30	4	962221	SCREW, HEX, .25-20 X 1.0, SS
31	12	980002	WASHER, LOCK, SPLIT, .25
32	4	920037	NUT, THIN JAM, 1/4-20, ZINC
33	2	870903	BRUSH, POLY, 16 INCH
33	2	870905	BRUSH, NYLON, 16 INCH
33	2	870907	BRUSH, GRIT, 16 INCH
33	2	875910	DRIVER, PAD, 16 INCH

ITEM	QTY	PART NUMBER	DESCRIPTION
37	1	876603	PLATE, MTG, 32INCH
38	1	204179 - 17.2"	TUBING, 1/4"
39	1	204179 - 7.0"	TUBING, 1/4"
40	1	204179 - 6.5"	TUBING, 1/4"
41	4	875603	BUMPER, RUBBER, WITH STUD
42	8	964448	SCREW, HEX, M6 X 16, SS, PATCH
43	2	870818	BRACKET, RETAINING, SEAL
44	2	224130 - 1.75"	TUBING, 1/2"
45	1	873308	FITTING, TEE, 0.50 INCH
46	2	853301	FITTING, REDUCER, BM08, BM04
47	1	224130 - 20.0"	TUBING, 1/2"
48	4	920011	NUT, NYLOCK, 1/4-20, ZINC
49	1	873802	GUIDE DRIVER RH
49	1	853803	GUIDE DRIVER LH
50	2	857009	PLUNGER BALL PRESS-IN

AVAILABLE PADS

PART NUMBER	DESCRIPTION
555903	PAD 16" BLACK STRIP CASE 5
555943	PAD 16" RED SCRUB CASE 5
555954	PAD 16" WHITE POLISH CASE 5

S-32 SCRUB HEAD

*** AFTER SERIAL NUMBER 121567 ***

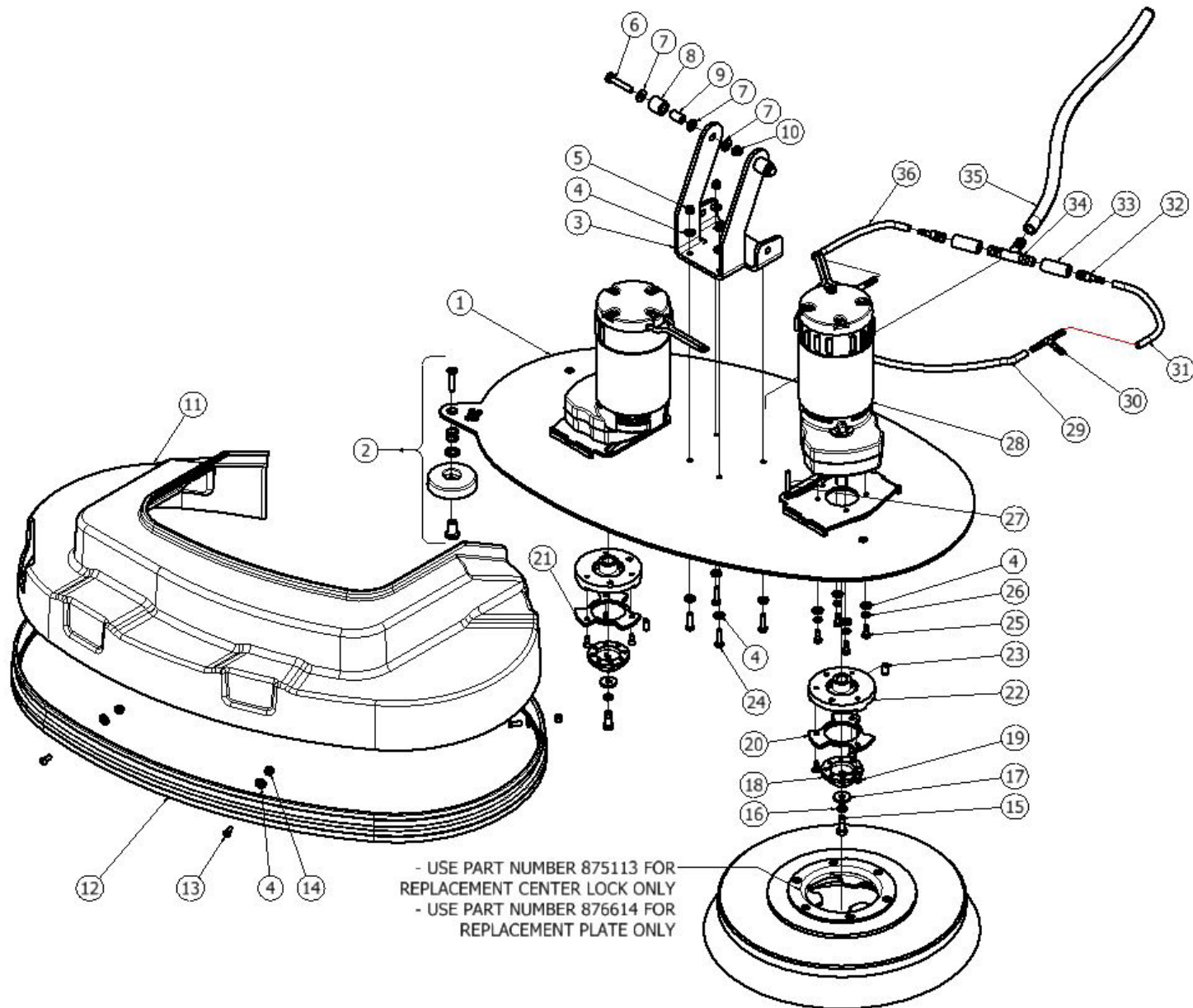

- USE PART NUMBER 875113 FOR
REPLACEMENT CENTER LOCK ONLY
- USE PART NUMBER 876614 FOR
REPLACEMENT PLATE ONLY

S-32 SCRUB HEAD

*** AFTER SERIAL NUMBER 121567 ***

ITEM	QTY	PART NUMBER	DESCRIPTION
1	1	876613	PLATE, MTG, 32INCH, RIGID
2	1	855022	KIT GUIDE WHEEL REPL ANTI-RATTLE
3	1	870804	BRACKET, SUPPORT, HEAD
4	20	W104D	WASHER, FLAT, .25
5	4	920011	NUT, NYLOCK, 1/4-20, ZINC
6	2	962270	SCREW, HEX, 5/16-18X1.75,SS
7	6	W243D	WASHER, FLAT, 5/16, SS
8	2	857501	ROLLER, PLASTIC
9	2	858203	SPACER, WHEEL, GUIDE
10	2	920012	NUT, NYLOCK, 5/16-18, ZINC
11	1	872306	SHROUD, HEAD, 32INCH
12	1	878502	SKIRT, BRISTLE
13	4	962263	SCREW, BUTT, SOCK, .25-20X.62, SS BO
14	4	920665	NUT, NYLOCK, 1/4-20, SS
15	2	962466	SCREW, HEX, M8-1.25 X 25, SS, PATCH
16	2	980094	WASHER, SPLIT LOCK, .31, SS
17	2	980107	WASHER, FLAT, .31ID, 1.0OD, .12THK, SS
18	2	853804	GUIDE, PAD, PLASTIC
19	6	962274	SCREW, FLAT, SOCK, .25-20X.62, SS, PATCH
20	1	873802	GUIDE, DRIVER, RH
21	1	853803	GUIDE, DRIVER, LH
22	2	854302	HUB, DRIVER, BRUSH
23	2	857009	PLUNGER BALL PRESS-IN
24	4	962221	SCREW, HEX, .25-20 X 1.0, SS
25	8	964448	SCREW, HEX, M6 X 16, SS, PATCH
26	8	980002	WASHER, LOCK, SPLIT, .25
27	2	915008	KEY, SQUARE, 5MM X 5 X 40MM
28	2	875203	MOTOR GEAR BRUSH MRP15 SERVICE
29	1	204179 - 17.2"	TUBING, 1/4"
30	2	873301	FITTING, TEE, .25INCH
31	1	204179 - 6.5"	TUBING, 1/4"

ITEM	QTY	PART NUMBER	DESCRIPTION
32	2	853301	FITTING, REDUCER, BM08, BM04
33	2	224130 - 1.75"	TUBING, 1/2"
34	1	873308	FITTING, TEE, 0.50 INCH
35	1	224130 - 20.0"	TUBING, 1/2"
36	1	204179 - 7.0"	TUBING, 1/4"
37	1	875021	ASSY SHROUD S32 REPLACEMENT (ITEMS 11 - 14)
38	1	850906	BRUSH CARBON KIT 4 PC 855204 & 875201

AVAILABLE PADS

PART NUMBER	DESCRIPTION
555903	PAD 16" BLACK STRIP CASE 5
555943	PAD 16" RED SCRUB CASE 5
555954	PAD 16" WHITE POLISH CASE 5
870905	BRUSH NYLON 16"
870907	BRUSH GRIT 16"
875910	DRIVER PAD 16"

S-28 ORBITAL SCRUB HEAD

(PAGE 1 OF 2)

ITEM	QTY	PART NUMBER	DESCRIPTION
1	1	870812	BRACKET, MTG, HEAD, ORBITAL
2	2	855022	KIT GUIDE WHEEL REPLACEMENT ANTI-RATTLE
3	1	876609	PLATE, MOUNTING, MOTOR
5	4	858203	SPACER, WHEEL, GUIDE
6	8	W243D	WASHER, FLAT, 5/16, SS
7	4	964009	SCREW, SCK, FLT, M6-1 X 20, SS, PATCH
8	2	852003	CLAMP, P-SHAPED, .62 DIA
9	2	962263	SCREW, BUTT, SOCK, .25-20X.62, SS BO
10	10	920665	NUT, NYLOCK, 1/4-20, SS
11	8	851101	BUSHING, RUBBER
12	4	858205	SPACER, RUBBER
13	2	857501	ROLLER, PLASTIC
14	1	875205	MOTOR ORBITAL SERVICE
15	1	850906	BRUSH CARBON KIT 4 PC 855204 & 875201
16	4	W117D	SCREW, HEX, .25-20 X 2.0, SS
17	2	962270	SCREW, HEX, 5/16-18X1.75,SS
18	1	915006	KEY, 8MM X 7MM X 28MM
19	4	980093	WASHER, WAVE, .50INCH
20	8	980104	WASHER, RUBBER
21	4	980094	WASHER, SPLIT LOCK, .31, SS
22	4	W405D	NUT, .31-18, JAM, SS
23	4	920012	NUT, NYLOCK, 5/16-18, ZINC
24	1	870813	BRACKET, SUPPORT, HEAD
25	1	204179	TUBING, 1/4"
26	1	853301	FITTING, REDUCER, BM08, BM04
27	4	962221	SCREW, HEX, .25-20 X 1.0, SS
28	8	W104D	WASHER, FLAT, .25
29	1	855116	LABEL PATENT ORBITAL HEAD
30	1	879005	TUBE DISTRIBUTION S-28 ORB
31	2	856802	PLUG .62 TUBE

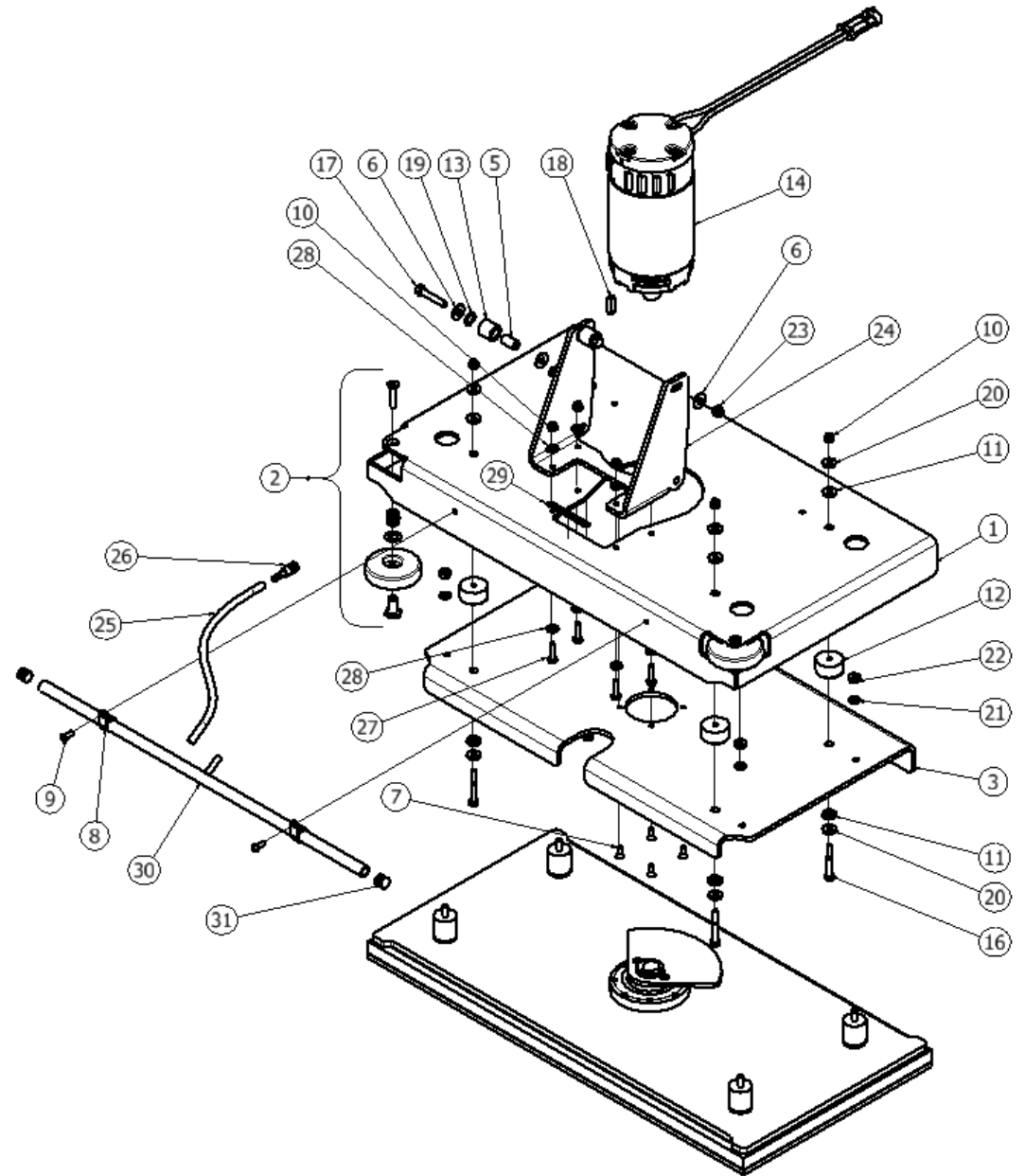

RETURN TO
TABLE OF
CONTENTS

S-28 ORBITAL SCRUB HEAD

(PAGE 2 OF 2)

AVAILABLE HEAD REBUILD KIT - #875022

Item	Item Description	Qty
877801	INSTRUCTION BOOKLET	1
204179	1/4 VINYL TUBING (1.3 FT)	1
851101	BUSHING FLNG URETHANE	8
852003	CLAMP PSHAPED .62DIA VINY	2
853301	FITTING,REDUCER,BM08,BM04	1
855604	MOUNT ISOLATOR .31THD	4
857501	ROLLER PLASTIC	2
858203	SPACER,WHEEL,GUIDE	4
858205	SPACE RUBBER	4
859703	WHEEL,GUIDE	2
875010	KIT, BEARING, REPL, ORBIT	1
875122	LOOM WIRE 1/4"	2
875801	O-RING, EPDM, 233	1
915006	KEY, 7MM X 8MM X 28MM DIN 6885	1
920011	NUT 1/4-20 HEX SS NYLOC H100013 920665	10
920012	NUT-5/16-18 ESNA LOCK H100011 TM934/935	4
962221	SCREW 1/4-20X 1 HH SS TM-H200068	4
962263	SCREW 1/4-20X.62 BUTTON SOCKET SS BLACK+	2
962266	SCREW 5/1618X1.5 SOCKETSS	2
962270	SCREW 5/16-18X1.75 HEX SS FULL THD	2
962274	SCREW 1/4-20X5/8 SCK FLT SS WITH LOCKIN+	4
962278	SCREW 5/16-18X7/8 SOCKET FLT WITH LO+	12
964009	SCREW M6-1X16 SCK FLT SS WITH LOCKING P+	4
964447	SCREW M8X16 FLAT SS PATCH	1
980093	WASHER .50 WAVE	4
980094	WASHER, LOCK, 5/16, SS	4
980104	WASHER,RUBBER 1/4 x 3/4 BONDED SS	8
980108	WASHER FLAT 5/16 1 .12 SS	4
W104D	WASHER 1/4 FLAT SAE S/S H300023	8
W117D	SCREW 1/4-20 x 2 HH SS	4
W243D	WASHER-5/16X.040 FLAT SS	8
W405D	NUT:5/16-18 HEX JAM SS	4

AVAILABLE PADS

PART NUMBER	DESCRIPTION
555909	PAD 14"X28" BLACK STRIP CASE 5
555929	PAD 14"X28" MAROON CFR CASE 5
555949	PAD 14"X28" RED SCRUB CASE 5
555969	PAD 14"X28" TURF CASE 4
555959	PAD 14"X28" WHITE POLISH CASE 5

ITEM	QTY	PART NUMBER	DESCRIPTION
1	1	875009	KIT, PLATE, REPL, ORBIT
2	1	876607	PLATE, ORBITAL, 28 INCH
3	1	875903	PAD, MIGHTYLOK ADH UNIVERSAL
4	1	875010	KIT, BEARING, REPL, ORBIT
5	2	962274	SCREW, FLAT, SOCK, .25-20X.62, SS, PATCH
6	1	964447	SCREW, FLT, M8 X 16, SS
7	12	962278	SCREW, SOCKET, FLT, .31-18X.88, SS, PATCH
8	1	876608	PLATE, BALANCE, 28 INCH
9	4	855604	MOUNT, ISOLATOR, .31THD
10	4	980108	WASHER, FLAT, .31ID, 1.25OD, .12THK, SS
11	1	875801	O-RING, EPDM, 233

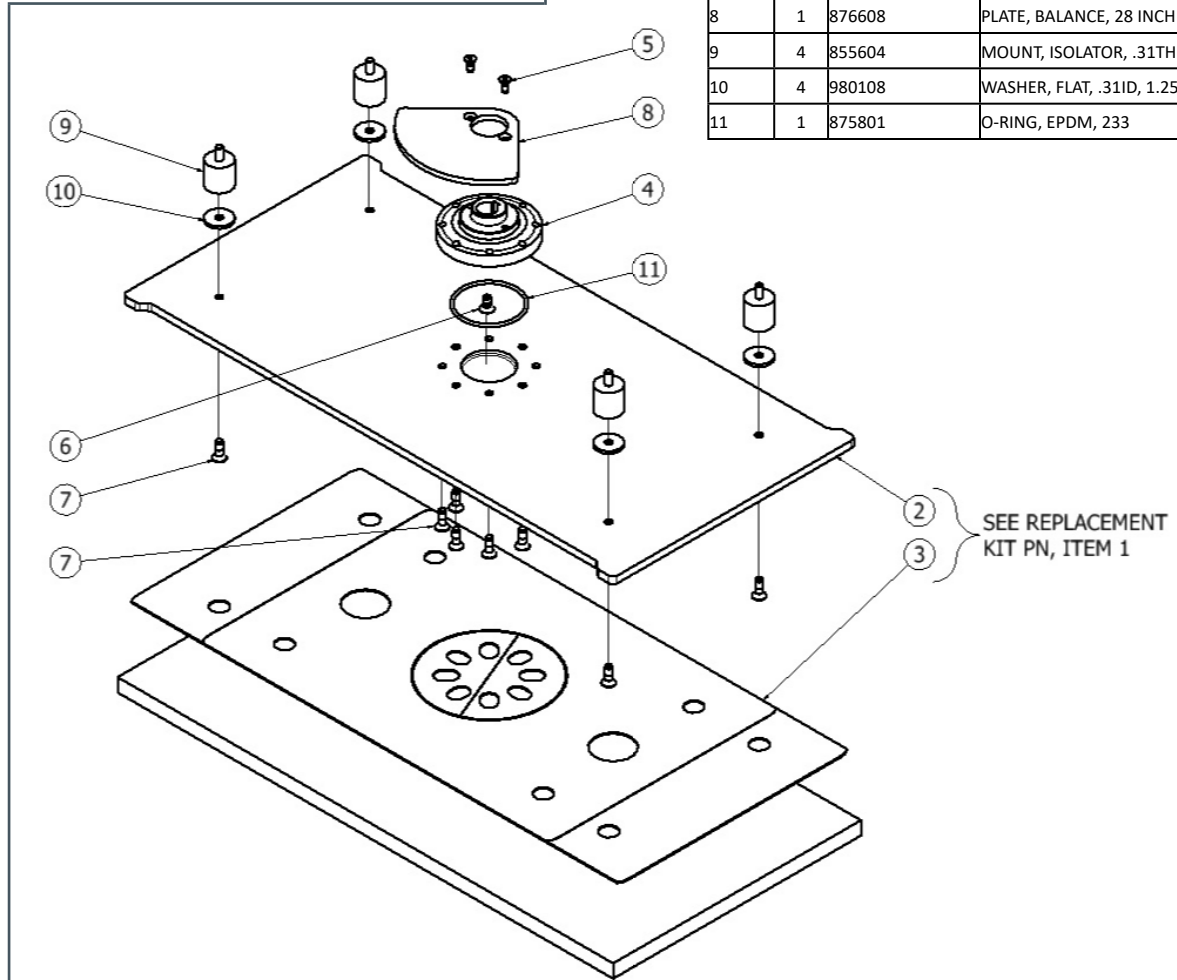

RETURN TO
TABLE OF
CONTENTS

S-24 WIRING DIAGRAM

ALL SERIAL NUMBERS

TROUBLESHOOTING TIPS:

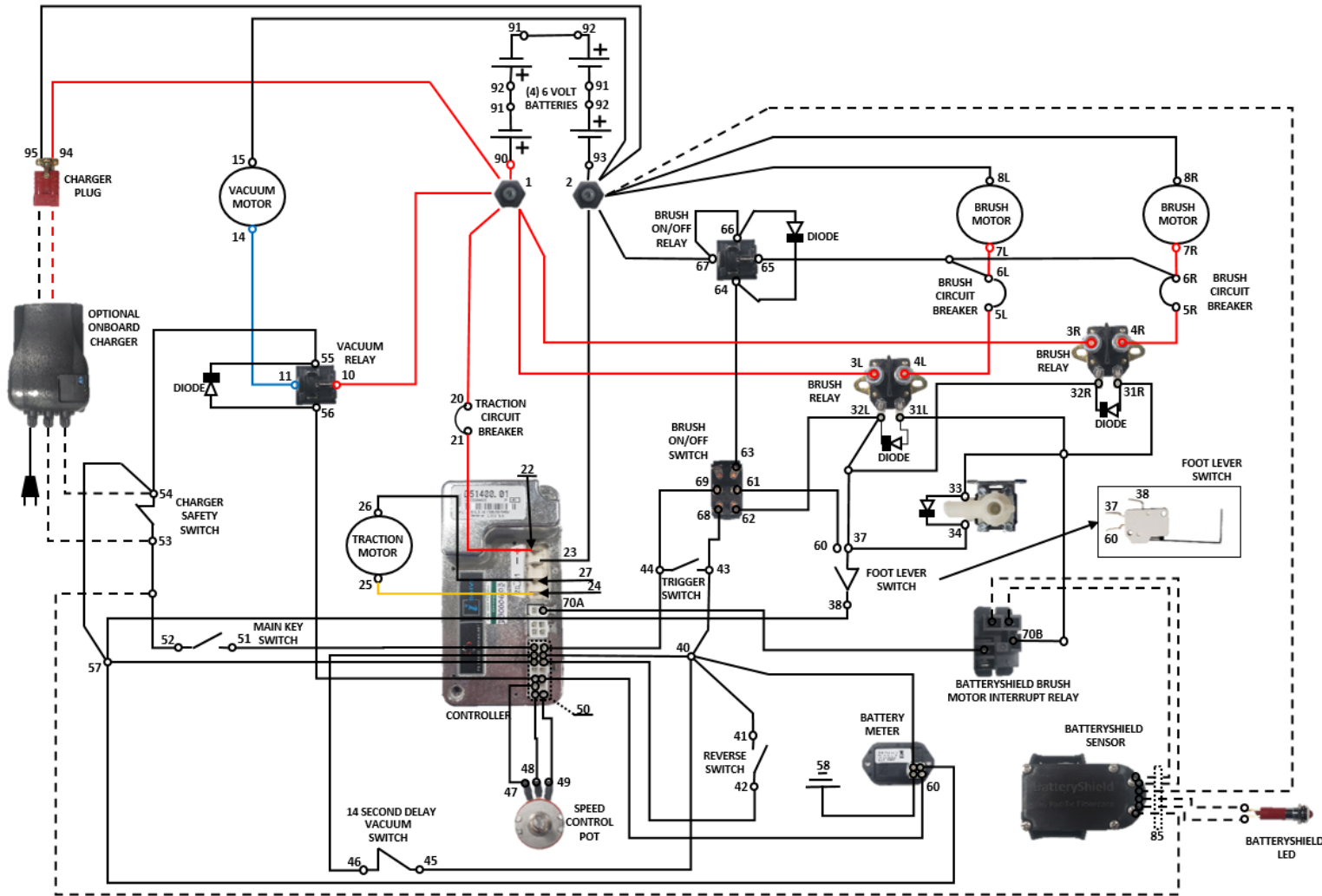

1. If the scrub head is not working when lowered, be aware that BatteryShield® intentionally disables the scrub head when the batteries need water. Refer to the **BATTERYSHIELD® AUTOMATIC WET BATTERY PROTECTION SYSTEM** section of this manual.
2. For machines equipped with BatteryShield®, refer to the optional **BATTERYSHIELD®** sections of this diagram and the **BATTERYSHIELD® AUTOMATIC WET BATTERY PROTECTION SYSTEM** section prior to proceeding.
3. If a yellow LED is flashing on the battery charger, verify continuity between the charger and the battery pack. Refer to the **ON-BOARD CHARGER** section of this manual.
4. A circuit breaker is designed to prevent overloading a component/system. If a circuit breaker continues to trip, verify the system is not being overloaded or that a wire is not chafed creating a short-circuit.

--- Wires represented with dashed lines indicate optional equipment installation

PAGE INTENTIONALLY BLANK

S-28 (DISK) & S-32 WIRING DIAGRAM

AFTER SERIAL NUMBER 113191

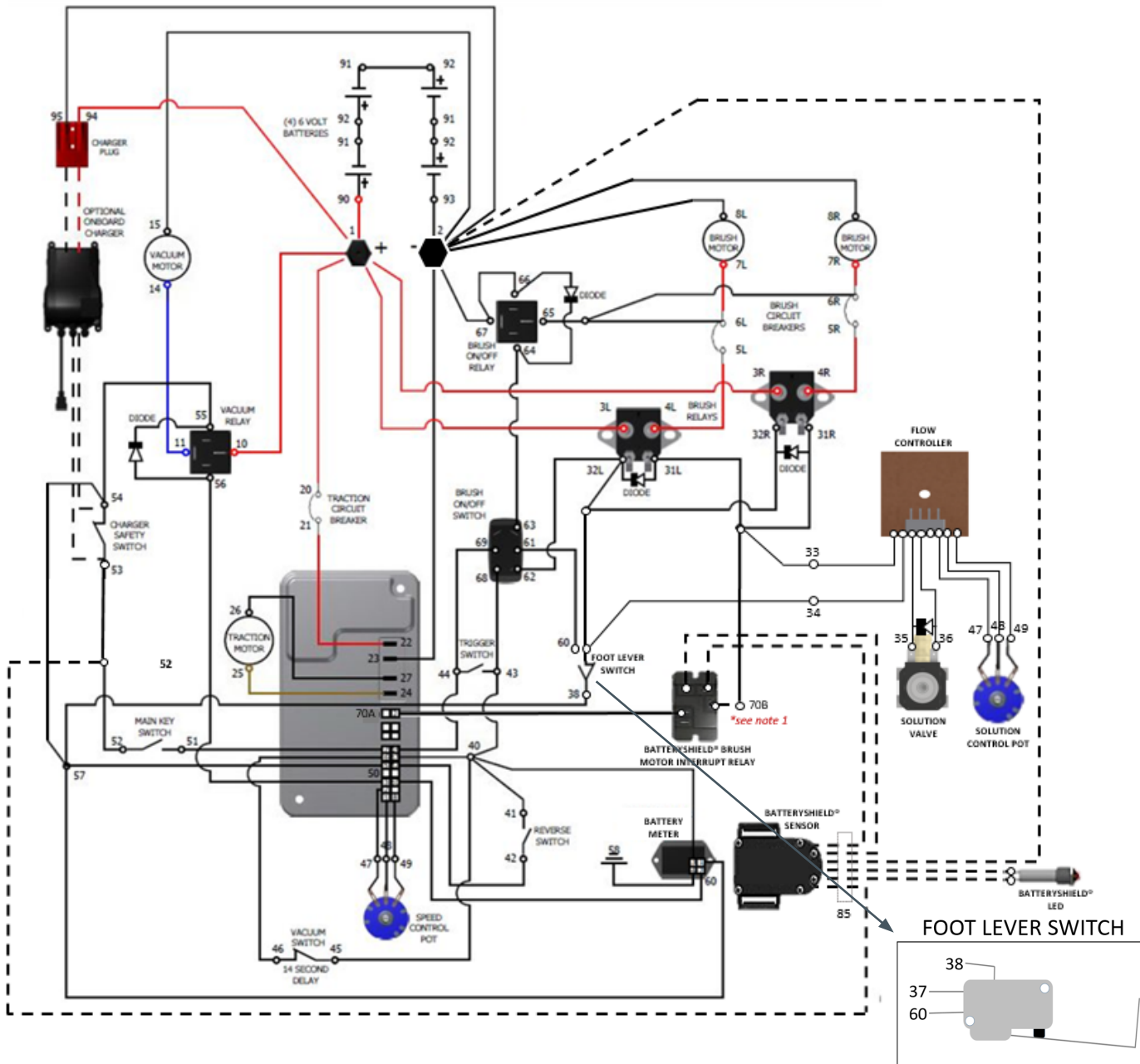

--- Wires represented with dashed lines indicate optional equipment installation

TROUBLESHOOTING TIPS

1. If the scrub head is not working when lowered, be aware that BatteryShield® intentionally disables the scrub head when the batteries need water. Refer to the **BATTERYSHIELD® AUTOMATIC WET BATTERY PROTECTION SYSTEM** section of this manual.
2. For machines equipped with BatteryShield®, refer to the optional **BATTERYSHIELD®** sections of this diagram and the **BATTERYSHIELD® AUTOMATIC WET BATTERY PROTECTION SYSTEM** section prior to proceeding.
3. If a yellow LED is flashing on the battery charger, verify continuity between the charger and the battery pack. Refer to the **ON-BOARD CHARGER** section of this manual.
4. A circuit breaker is designed to prevent overloading a component/system. If a circuit breaker continues to trip, verify the system is not being overloaded or that a wire is not chafed creating a short-circuit.

RETURN TO
TABLE OF
CONTENTS

S-28 (DISK) & S-32 WIRING DIAGRAM

PRIOR TO SERIAL NUMBER 113191

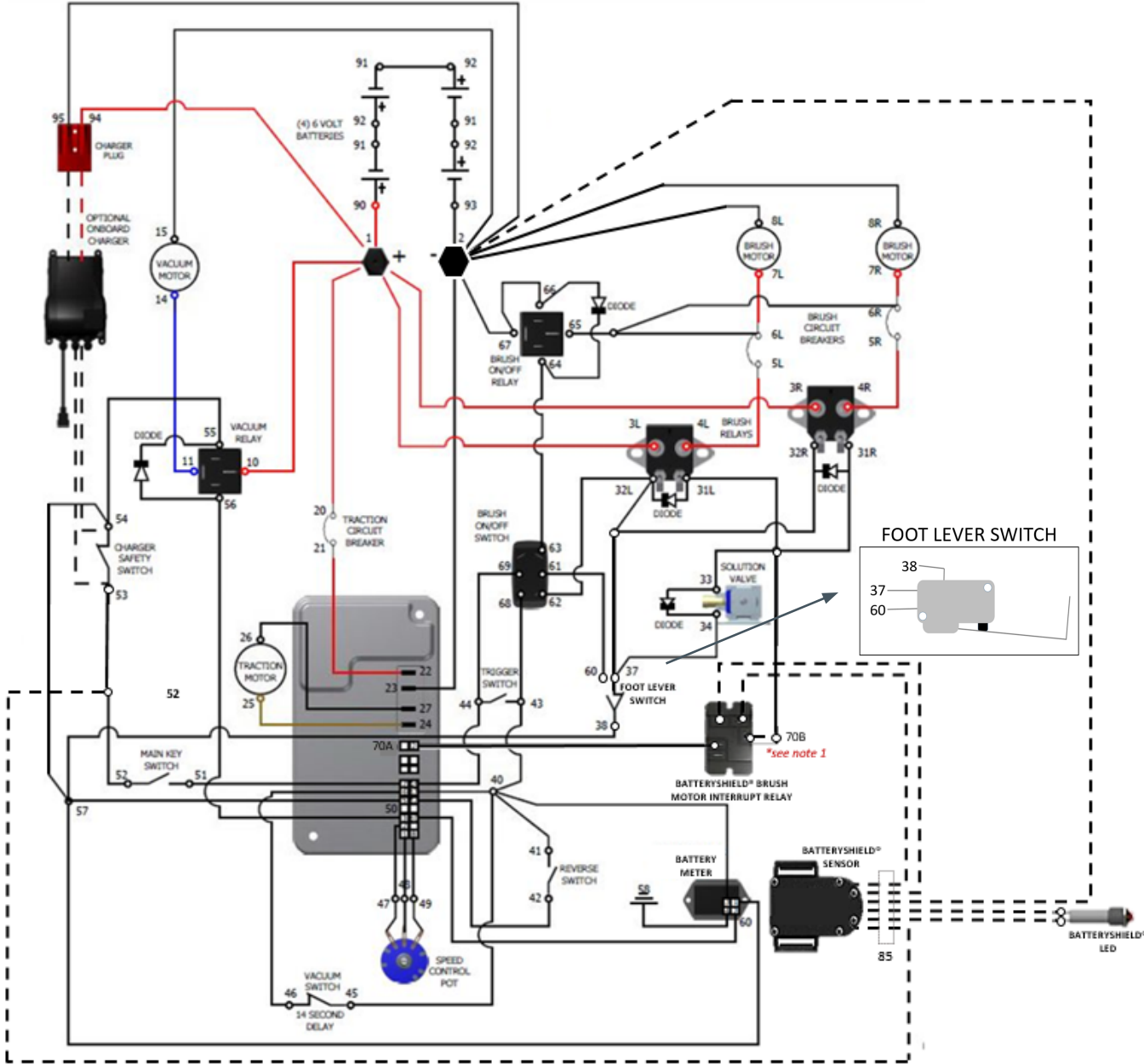

TROUBLESHOOTING TIPS:

1. If the scrub head is not working when lowered, be aware that BatteryShield® intentionally disables the scrub head when the batteries need water. Refer to the **BATTERYSHIELD® AUTOMATIC WET BATTERY PROTECTION SYSTEM** section of this manual.
2. For machines equipped with BatteryShield®, refer to the optional **BATTERYSHIELD®** sections of this diagram and the **BATTERYSHIELD® AUTOMATIC WET BATTERY PROTECTION SYSTEM** section prior to proceeding.
3. If a yellow LED is flashing on the battery charger, verify continuity between the charger and the battery pack. Refer to the **ON-BOARD CHARGER** section of this manual.
4. A circuit breaker is designed to prevent overloading a component/system. If a circuit breaker continues to trip, verify the system is not being overloaded or that a wire is not chafed creating a short-circuit.

--- Wires represented with dashed lines indicate optional equipment installation

RETURN TO
TABLE OF
CONTENTS

S-28 ORBITAL WIRING DIAGRAM

PRIOR TO SERIAL NUMBER 113191

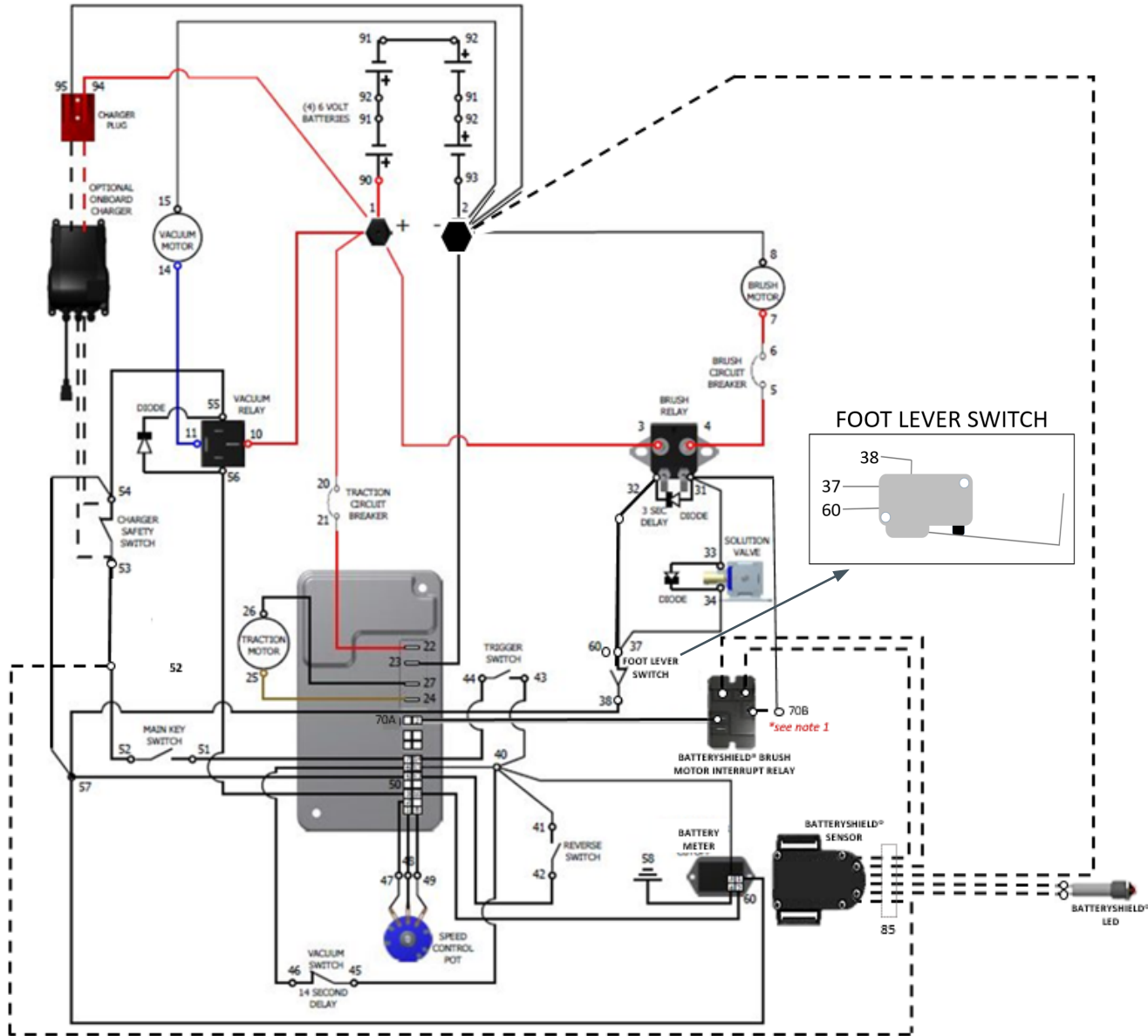

TROUBLESHOOTING TIPS

1. If the scrub head is not working when lowered, be aware that BatteryShield® intentionally disables the scrub head when the batteries need water. Refer to the **BATTERYSHIELD® AUTOMATIC WET BATTERY PROTECTION SYSTEM** section of this manual.
2. For machines equipped with BatteryShield®, refer to the optional **BATTERYSHIELD®** sections of this diagram and the **BATTERYSHIELD® AUTOMATIC WET BATTERY PROTECTION SYSTEM** section prior to proceeding.
3. If a yellow LED is flashing on the battery charger, verify continuity between the charger and the battery pack. Refer to the **ON-BOARD CHARGER** section of this manual.
4. A circuit breaker is designed to prevent overloading a component/system. If a circuit breaker continues to trip, verify the system is not being overloaded or that a wire is not chafed creating a short-circuit.

--- Wires represented with dashed lines indicate optional equipment installation

RETURN TO
TABLE OF
CONTENTS

S-28 ORBITAL WIRING DIAGRAM

AFTER SERIAL NUMBER 113191

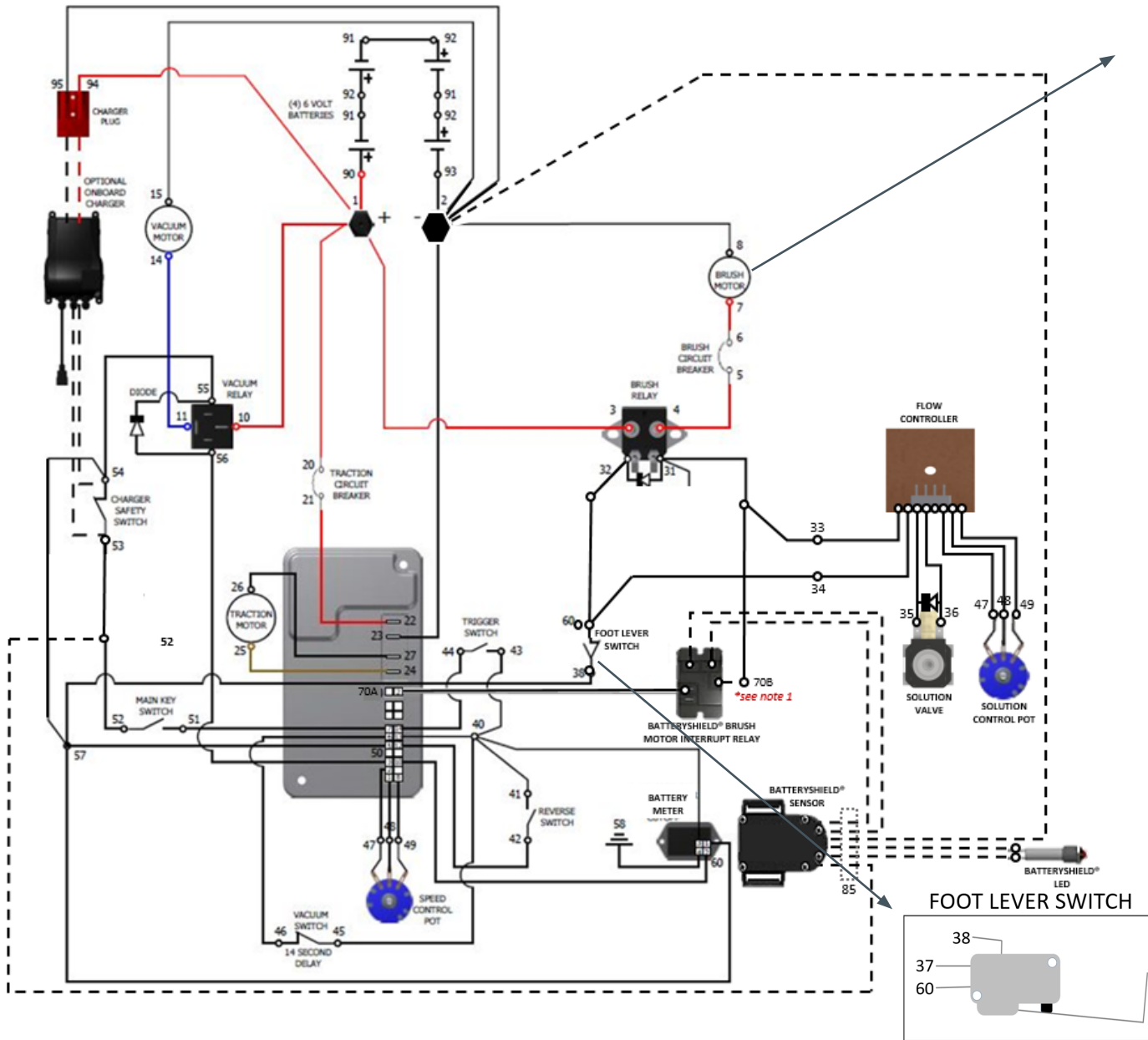

TROUBLESHOOTING TIPS

1. If the scrub head is not working when lowered, be aware that BatteryShield® intentionally disables the scrub head when the batteries need water. Refer to the **BATTERYSHIELD® AUTOMATIC WET BATTERY PROTECTION SYSTEM** section of this manual.
2. For machines equipped with BatteryShield®, refer to the optional **BATTERYSHIELD®** sections of this diagram and the **BATTERYSHIELD® AUTOMATIC WET BATTERY PROTECTION SYSTEM** section prior to proceeding.
3. If a yellow LED is flashing on the battery charger, verify continuity between the charger and the battery pack. Refer to the **ON-BOARD CHARGER** section of this manual.
4. A circuit breaker is designed to prevent overloading a component/system. If a circuit breaker continues to trip, verify the system is not being overloaded or that a wire is not chafed creating a short-circuit.

--- Wires represented with dashed lines indicate optional equipment installation

RETURN TO
TABLE OF
CONTENTS

BATTERYSHIELD® (OPTIONAL) WIRING DIAGRAM

NOTE: BatteryShield® intentionally interrupts the scrub head circuit when the batteries need water. Refer to the BATTERYSHIELD® AUTOMATIC WET BATTERY PROTECTION SYSTEM section of this manual.

BATTERYSHIELD® SENSOR IS MATED AND CALIBRATED TO THE MANIFOLD (BATT CAP) FROM THE FACTORY. SENSOR AND CAP MUST BE REPLACED AS AN ASSEMBLY – **DO NOT REMOVE SENSOR FROM CAP**

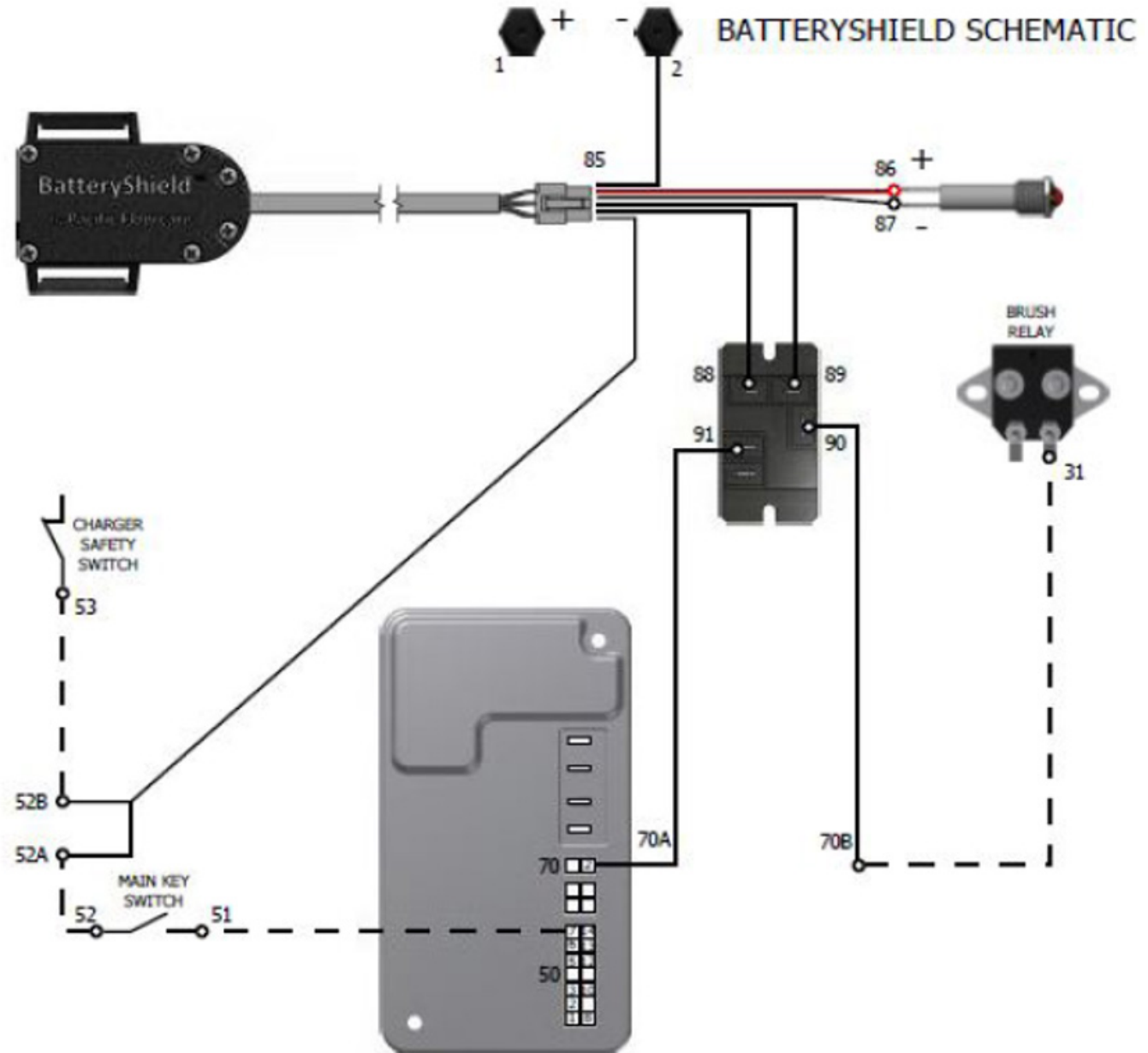

OPTIONAL CHEMICAL INJECTION WIRING DIAGRAM

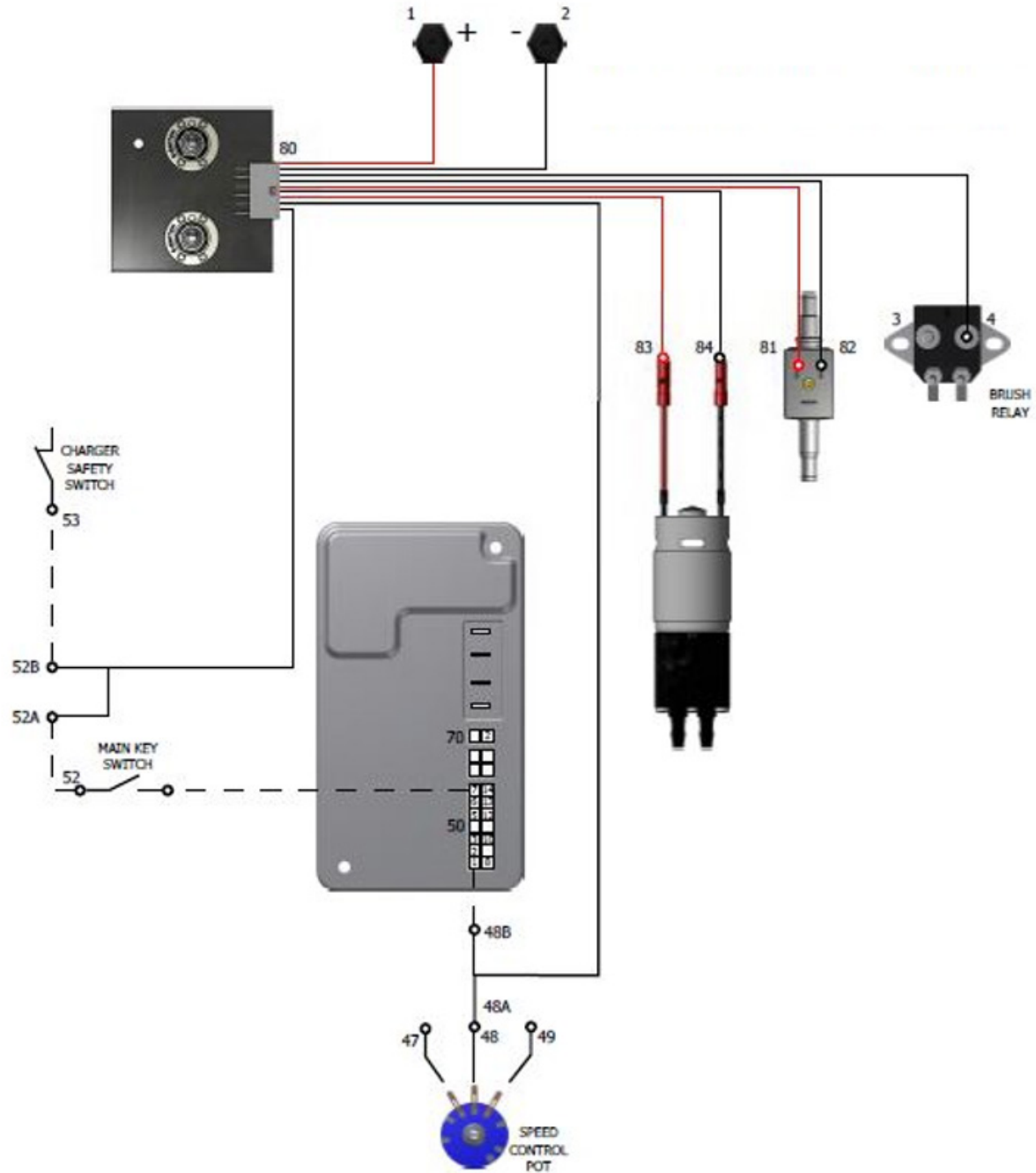

PAGE INTENTIONALLY BLANK



PACIFIC[®]
F L O O R C A R E

PURPOSE BUILT.[®]

www.pacificfloorcare.com