

# SEMI-AUTO SCRUBBERS

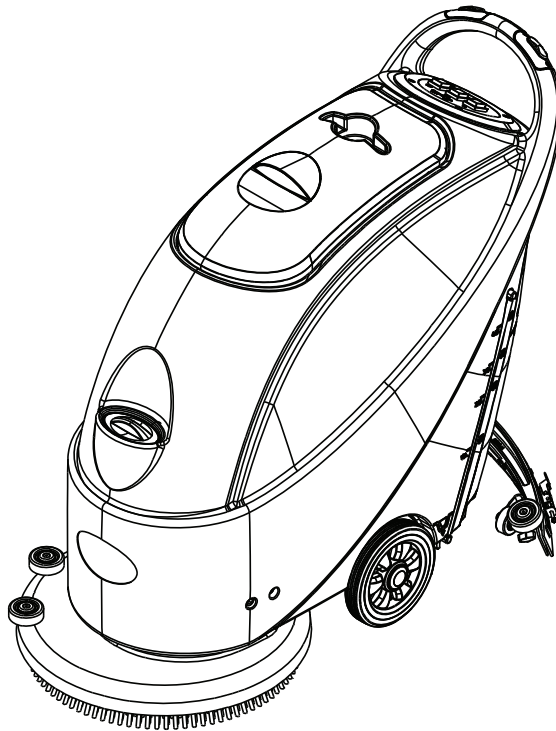

CleanFreak  
3900 N. Providence Ave.  
Appleton, WI 54913

Toll free. 888-722-5508  
Local.920-882-8453  
Fax.920-380-0878

**Instructions For Use - Original Instructions / Instrucciones de uso / Mode d' emploi**  
**Model: CPL DURA-17C**



**READ THIS BOOK**

**EN**

**English (A2 - A15)**



This book has important information for the use and safe operation of this machine. Failure to read this book prior to operating or attempting any service or maintenance procedure to your machine could result in injury to you or to other personnel; damage to the machine or to other property could occur as well. You must have training in the operation of this machine before using it. If your operator(s) cannot read this manual, have it explained fully before attempting to operate this machine.

All directions given in this book are as seen from the operator's position at the rear of the machine.

## TABLE OF CONTENTS

	Page
<b>Introduction</b> .....	<b>A-3</b>
Contents .....	A-3
Purpose .....	A-3
Spare Parts and Maintenance .....	A-3
Changes and Improvements .....	A-3
Machine Application.....	A-3
Unpacking/Transport .....	A-3
Safety Guides .....	A-4
Technical Data .....	A-5
<b>Machine Components</b> .....	<b>A-6 – A-7</b>
Control Panel.....	A-6 – A-7
<b>Guide For Use</b> .....	<b>A-8</b>
Before Machine Start-Up .....	A-8
Brush / Pad-Holder Installing and Removal.....	A-8
Squeegee Adjustment .....	A-8
Regulating Water Flow .....	A-9
Machine Start and Stop .....	A-9
Machine Operation .....	A-10
Tank Emptying .....	A-10
After Each Use .....	A-11
Using For the First Time .....	A-11
<b>Maintenance and Care</b> .....	<b>A-12</b>
Scheduled Maintenance Table .....	A-12
Squeegee Cleaning .....	A-12
Squeegee Blade Check and Replacement.....	A-13
Brush/ Pad Cleaning.....	A-13
Water Tank and Float Filter Mesh Cleaning.....	A-14
Solution Filter Cleaning .....	A-15
<b>Troubleshooting</b> .....	<b>A-15</b>
<b>Parts List</b> .....	<b>B-2 – B-12</b>

## INTRODUCTION

### NOTE

Numbers shown in parenthesis correspond with the numbers in the machine exploded view.

## CONTENTS

This manual is intended to provide the operator with the necessary information to use this machine properly and safely. The information includes technical data, safety, operation, storage, maintenance and disposal of the machine. All operators and technicians should study this manual carefully before prior to operating or servicing the machine. Please contact an authorized service provider with any questions.

## PURPOSE

The intention of this manual is to educate the operator and service provider on the proper use and maintenance of this machine.

## SPARE PARTS AND MAINTENANCE

Before servicing the machine park on level ground and unplug cord from the outlet.

All necessary operation, maintenance, and repair procedures must be performed by an authorized service provider.

Only authorized spare parts and accessories should be used.

If service, parts or accessories are needed, please contact an authorized service center.

## CHANGES AND IMPROVEMENTS

We make continuous improvements to our products and reserve the right to change and improve the machines.

improvements should be performed by an authorized service provider.

## MACHINE APPLICATION

This scrubber is used in commercial and industrial environments and is suitable for the cleaning of smooth hard floor surfaces. It must be used by qualified operators and in a safe environment. This machine is not to be used outdoors, on carpets, and on coarse floors.

## UNPACKING/TRANSPORT

Please follow carefully the instructions on the package when unpacking.

Upon delivery, please inspect the packing and the machine to ensure no damage has been done during transport. If there is any visible damage, please contact the distributor you purchased the machine from.

## CAUTION !

When unpacking and unloading, or during transportation, please take care to avoid hitting the solution valve. Part A in the figure on the right.

Check if the machine is equipped with the following items:

1. Machine
2. User manual
3. Squeegee assembly
4. Brush/pad driver

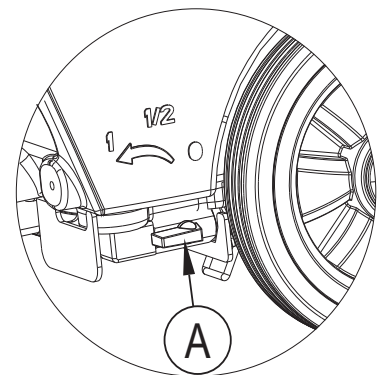

## SAFETY GUIDES

The following are special warnings and notices on potential damages (personnel and machine):

### WARNING !

- Machine may only be operated under the guidance of this manual. Only accessories approved by authorized service provider should be used.
- This machine must be only used by trained & authorized personnel. Children or untrained persons must not use this machine.
- When working near electrical parts, please do not wear any jewelry. Please take all precautionary measures to avoid hair, jewelry, and loose fitting clothing from being caught by any moving parts of the machine.
- Prior to scrubbing, it is best to pre-sweep the area to be cleaned. Do not wash the machine directly with water. Do not let the machine come in touch with corrosive liquids.
- The temperature for storage and for working environment of the machine must be between 0 - 40°C.
- The humidity of air must be between 30% - 105%.
- Please do not use the machine on a slope with a gradient of more than 2%.
- In case of fire, please use dry powder fire extinguishers. Do not use liquid fire extinguishers.
- Particular attention should be paid when the machine is transported below 0°C. The water tank and the water in the hoses may freeze and cause serious damages to the machine.
- Use brush or pad driver supplied with the machine and those specified in the owner's manual. Using other brushes or pads could reduce safety.
- In case of machine malfunction, please make sure that it is not caused by lack of maintenance. If it is caused by other conditions, contact authorized service center. If it is confirmed that spare parts must be replaced, please secure the genuine parts from authorized service provider.
- In order to ensure safe and proper operation of the machine, it is advised that an authorized service provider perform the scheduled maintenance according to the maintenance schedules outlined in this manual.
- This machine must be properly disposed of in accordance with local laws and regulations (please refer to machine disposal section).

**TECHNICAL DATA**

Machine Height	980mm
Solution tank capacity	50 litre
Recovery tank capacity	50 litre
Diameter of transport wheel	200mm
Diameter of guide wheel	63.5mm
Power of vacuum system motor	400w
Maximum gradient when working	2% (Max)
Sound pressure level at workstation	72dB(A) $\pm$ 3dB(A)
Cable Length	20m
Vacuum system circuit capacity	1200 mm H <sub>2</sub> O
Cleaning width	430mm
Squeegee width	730mm
machine maximum length	1060mm
Machine width without squeegee	480mm
Brush diameter	430mm
Weight with empty tanks	70kg
Gross weight of the machine ready for use	120kg
Brush motor power	750W
Brush speed	150rpm
Brush /pad-holder Maximum pressure	32kg(Max)
Packing size (Lx W x H)	1200 x 610 x 1170mm

**MACHINE COMPONENTS**

1. Safety switch button
2. Handle
3. Control panel
5. Control cover
6. N/A
7. N/A
8. Reset switch
9. Power Cable
10. Cover
11. Drain hose
12. Squeegee lift cable
13. N/A
14. Squeegee lift handle
15. Drain cap
16. Squeegee knob
17. Squeegee clip
18. Squeegee blade
19. Squeegee bracket
20. Squeegee adjusting knob
21. Squeegee rear support frame
22. Squeegee front support frame
23. Cup holder
24. Recovery tank cover handle
25. Recovery tank lid
26. Recovery tank
27. Solution fill
28. Brush deck
29. Brush / pad-holder
30. Vacuum motor
31. Brush motor
32. 8" wheel
33. N/A
34. Vacuum tube
35. Electric Box
36. Float filter
37. Water level site tube

**CONTROL PANEL**

38. Power switch
39. Vacuum switch
40. Solution switch

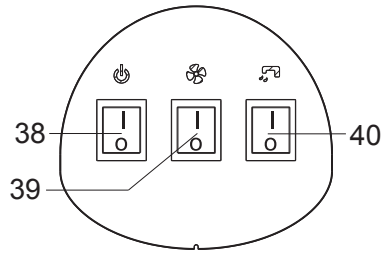
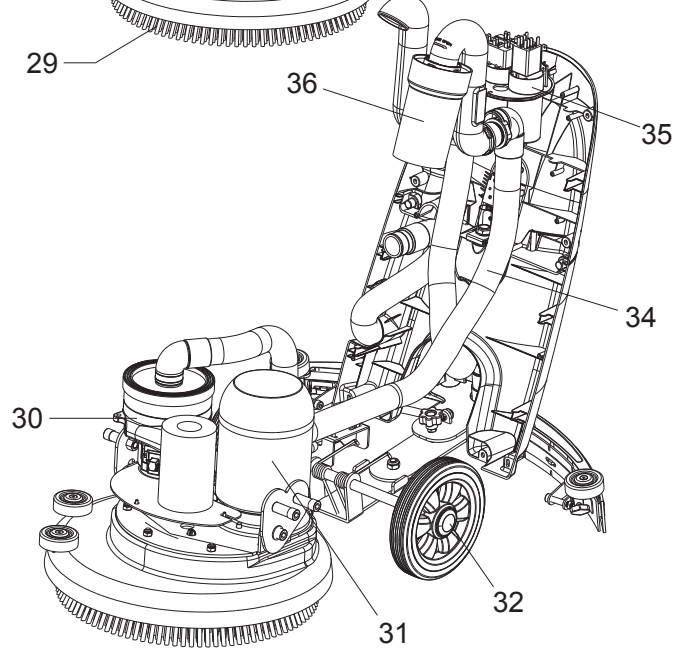
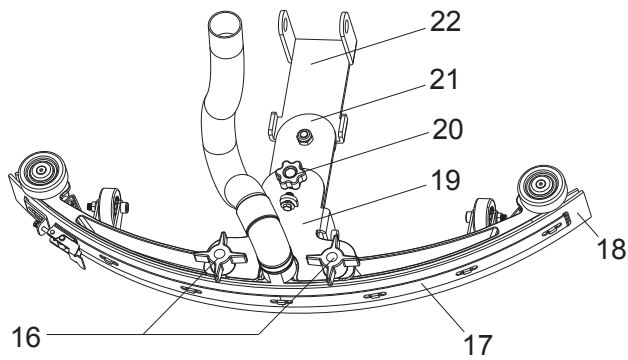
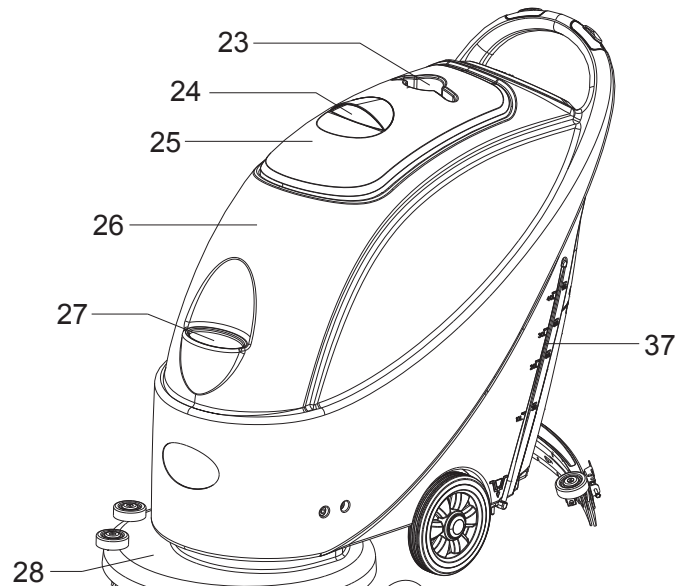
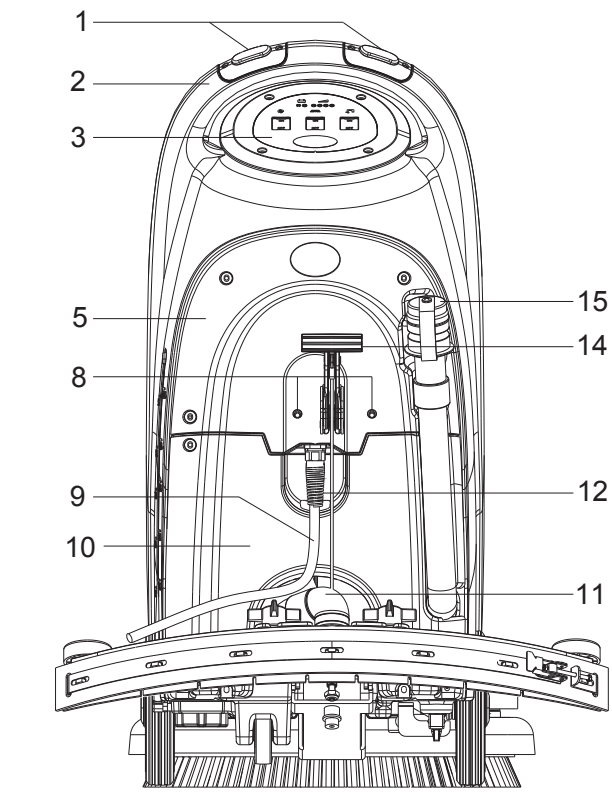

## GUIDE FOR USE

### ⚠ WARNING !

On certain parts of the machine are pasted some indicative signs:

### ⚠ DANGER !

### ⚠ WARNING !

### ⚠ CAUTION !

## CONSULTATION

When reading this manual, the operator must pay particular attention to the symbols on these labels. Under no circumstances shall these labels be covered. If they are damaged, please replace them immediately.

## BEFORE MACHINE START-UP

### BRUSH / PAD-HOLDER INSTALLING AND REMOVAL

#### NOTE

According to the type of floor to be cleaned, the machine may be installed with brush (Figure 3, A), or a pad-holder (Figure 3, B and C).

### ⚠ CAUTION !

When manually installing or removing the brush/pad-holder, first ensure that all the switches are in the "off" position and lift the squeegee off the floor. Only after which can the brush or pad-holder be worked on.

Always wear protective gloves.

1. Make sure the power cable (9) disconnecting the power supply and the switch (38) is at the disconnecting (Off) condition.
2. Press down the handle (2) to lift the tank body (26).
3. Put the brush (A) or the pad-holder (B – C) under the case.
4. Use the handle (2) to lower the tank body (26) to come into contact with the brush or pad-holder.
5. Manually attach by following the arrow head (D) to install the brush/pad-holder (as shown in Figure 3).
6. Remove by turning the brush/pad-holder in the opposite direction and it can be taken off. (Figure 3)

## SQUEEGEE ADJUSTING

7. Install the squeegee and tighten the knobs. Then connect the vacuum hose to the squeegee assembly.
8. Adjust the squeegee through the adjusting handle (A) of the squeegee (Figure 4).
  1. If the mid-section of the rear squeegee bracket, section B, has a gap with the floor or the downward pressure is relatively light, adjust the handle in an anti-clockwise direction until the whole length of the rear squeegee strip touches well with the floor. The front squeegee strip should lightly touch the floor.
  2. If the two ends of the rear squeegee strip, sections C and D, have a gap with the floor or the downward pressure is relatively light, adjust the handle in a clockwise direction until the whole length of the rear squeegee strip touches well with the floor. The front squeegee strip should lightly touch the floor.

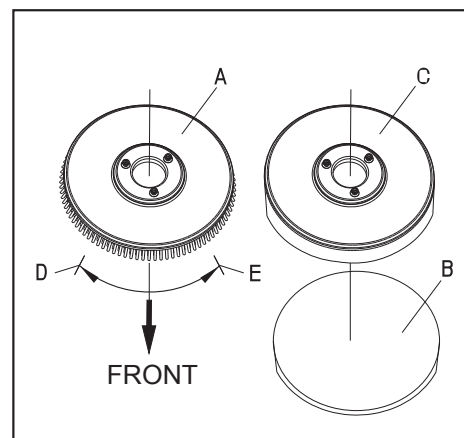

**FIGURE 3**



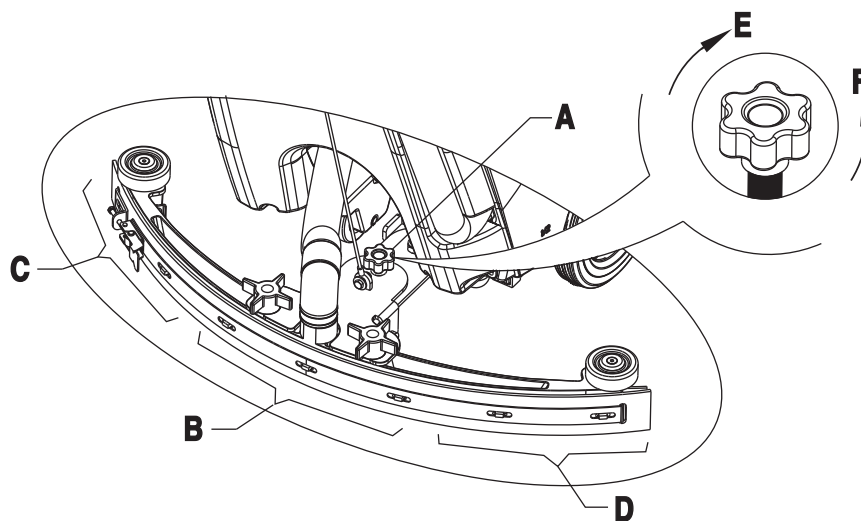

FIGURE 4

### SOLUTION TANK FILLING

#### ⚠ CAUTION !

Only low foam, nonflammable detergents may be used. These detergents must be suitable for the use of scrubbers. Foam must not enter the vacuum shut-off screen or damage to the vacuum motor may occur. Foam will not activate the float shut-off device.

- Open the water inlet cover (27) and add water to solution tank. Do not overfill the tank. When preparing the cleaning solutions, please follow the dilution rates supplied by the chemical manufacturer. Water temperature must not exceed 40°C.

### REGULATING WATER FLOW

#### ⚠ WARNING !

Regulating the ball valve handle (A, Figure 5) must be done under the condition when the power switch (38) is in the "Off" position.

- The volume of the water flow may be adjusted through the ball valve handle (A, Figure 5) according to the amount of water required for your scrubbing application.

### MACHINE START AND STOP

#### ⚠ CAUTION !

Do not keep the machine in the same position while the brush/pad is spinning. Floor damage may result.

Read and understand this manual before operating the machine.  
Starting the machine

- Complete the preparatory steps as outlined above.
- Press the power switch (38) to the "I" position.
- Use the squeegee handle (14) to lower the squeegee.
- Press the Vacuum switch (39) to the "I" position.
- Press the solution switch (40) to the "I" position. (Work simultaneously with the safety switch (1) to control the solenoid valve.)
- Squeeze the on / off switch (1) and push to move the machine. When switches are squeezed, the brush (29) will rotate, and the solution will flow.

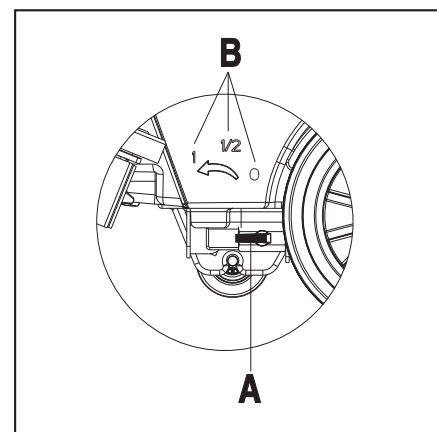

FIGURE 5

### CONSULTATION:

Each safety switch is capable of controlling independently the operation of the brush. In use, it facilitates the control of the operation of the machine. Operators are encouraged to find the most comfortable position their hands.

## TURNING OFF THE MACHINE

7. When you have finished using the machine, first remove the brush/pad-holder (refer to the steps mentioned above)
8. Release the safety switch (1) to turn off the brush/pad holder and solenoid valve.
9. Press the Vacuum switch (39) to the "Off" position, and the Vacuum will delay for 5 seconds before stopping work.
10. Press the solution control switch (40) to the "Off" position to completely turn off the solution flow.
11. Press the power switch (38) to the "Off" position. And disconnecting the power cable (9) from the power supply.
12. Use the squeegee lift handle (14) to lift the squeegee.
13. Grasp the handle (2) and gently tilt the machine backward until the guide wheel (B) touches the floor. See Figure 7.



FIGURE 6

## MACHINE OPERATION

1. Start the machine according to the description above.
2. Hold the on / off switch (1) (Figure 6), push to move the machine, and start the scrubbing.
3. If necessary, turn off the machine, and adjust the squeegee. (Refer to the steps for squeegee adjustment)
4. If necessary, turn off the machine, and adjust the solution flow with the ball valve handle. (Refer to the steps for adjusting solution flow).

## ⚠ CAUTION !

In order to avoid damaging the floor, when the machine stays in one place without moving, remove hands from switches & turn off the main power switch (38).

## TANK EMPTYING

When recovery tank is full, a float shut-off device (36) will block the inlet connecting to the vacuum motor. Through a sudden increase of noise from the vacuum motor, it can be considered that the recovery tank is full and requires immediate draining.

## ⚠ CAUTION !

If the vacuum motor is suddenly turned off (due to sudden movement resulting in an activation of the float), and if a resumption of operation is needed, please perform the following steps: press the power switch (38 and 39) to turn off the power and the vacuum motor, and open the recovery tank cover (25) to check if the float has returned to the water surface. Close the recovery tank cover (25), and press the power switch (38 and 39) to turn on the main power and the vacuum motor.

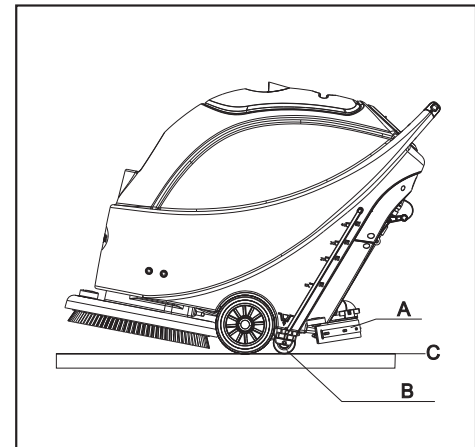

FIGURE 7

## RECOVERY TANK EMPTYING

1. Turn off the machine.
2. Raise the squeegee assembly (14).
3. Move the machine to a dedicated draining location.
4. Grasp the handle (2) and tilt the machine backward until the guide wheel touches the floor.
5. Remove the drain hose from the clip, bend the top end of draining hose (A, Figure 8), and then remove the drain hose cap. Lower the hose to a low level or on the ground to drain the water. Alternatively, place drain hose to a low position or on the ground to make the water outlet face downward (B, Figure 8), and then twist open the drain cap to drain the wastewater in the tank. After draining is completed, rinse the inside of recovery tank with clean water

### **⚠ CAUTION !**

When draining the wastewater, the drain hose must be folded or lowered to a lower position (Figure 8 A or B), and the cap removed for wastewater to drain. Do not allow the opening of the drain hose to face upward, as it could get wastewater on the operator.

## SOLUTION TANK EMPTYING

6. Complete Steps 1 to 4.
7. As shown in Figure 9, turn open the lid of Solution tank (A) counter clockwise (direction C), to drain Solution tank completely. Use clean water to rinse the inside of Solution tank. When work is completed, replace the solution tank lid (A) by twisting in a clockwise in direction (B).

## AFTER EACH USE

When work is done and before leaving the machine, completes the following steps:

1. Remove the brush / pad holder.
2. Drain solution tank & rinse with clean water.
3. Drain recovery tank & rinse with clean water.
4. Complete the daily maintenance procedures. (see maintenance section)
5. Remove and rinse squeegee assembly with damp towel.
6. Keep recovery tank lid unsealed from tank to allow fresh air to circulate freely

## USING FOR THE FIRST TIME

After the first 9 hours of use, please check components to ensure all connections (electrical & mechanical) are tight & check for any damage that may have occurred during operation. Check for water leakage.

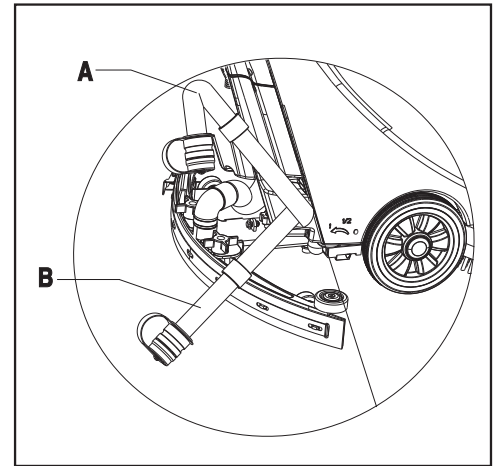

FIGURE 8

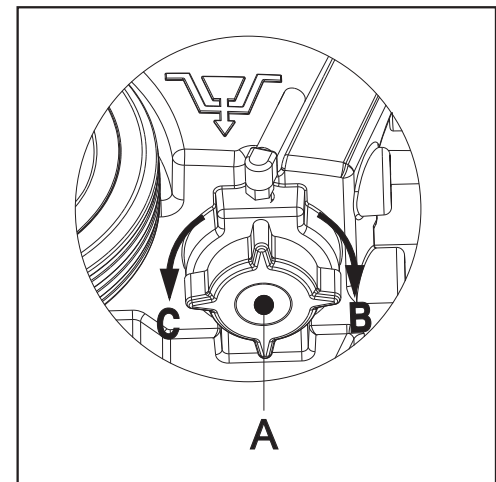

FIGURE 9

## MAINTENANCE AND CARE

The service life and the maximum operation safety of the machine are assured by proper and timely maintenance and care.

The following table is a routine maintenance guide for the machine. The time intervals of maintenance are determined to a large extent by the working conditions of the machine. These time intervals should be formulated by the person responsible for the maintenance.

### ⚠ WARNING !

Only after the main power is disconnected should these procedures be performed. Prior to proceeding with any of the maintenance procedures, please study carefully the related safety sections.

All maintenance should be done by qualified personnel or an authorized service centers.

This manual only relates the simplest and the most common maintenance procedures.

For any maintenance procedures other than those stated in this table of planned maintenance, please contact an authorized distributor.

## SCHEDULED MAINTENANCE TABLE

	After each use	Weekly	Every six months	Annually
Clean Squeegee				
Clean Brush/Pad holder				
Clean water tank and float filter, inspect tank gaskets				
Inspect and change the squeegee blades				
Clean solution filter				
Clean Vacuum motor filter				
Inspect tightness of nuts and bolts			(1)	
Check brush motor carbon brushes				(2)
Check vacuum motor carbon brushes				(2)

(1) = After the first 9 working hours.

(2) = This maintenance procedure must be performed by an authorized Service Center.

## SQUEEGEE CLEANING

### NOTE

In order to maintain the optimal squeegee performance, the squeegee must be kept clean, and the squeegee blades must remain in good condition.

### ⚠ CAUTION !

When cleaning the squeegee, it is recommended to put on protective gloves as the squeegee may contain sharp debris.

1. Move the machine to a flat and smooth surface.
2. Press the power switch (38) to the "O" position to turn off the machine.
3. Unscrew the squeegee knobs (16); remove the vacuum hose from the squeegee assembly & remove squeegee.
4. Use the squeegee lift handle (14) to lift the squeegee mount bracket.
5. Using a damp towel, clean the squeegee (Figure 10). Clean in particular the groove (A, Figure10) and the dirt and fragments on the vacuum tube. Check if the front squeegee blade (C) and the rear squeegee blade (D) are intact, and if there are broken edges and cracks. Replace them if necessary (refer to the steps in the following section).
6. Re-install the squeegee in the reverse order of the above

FIGURE 10

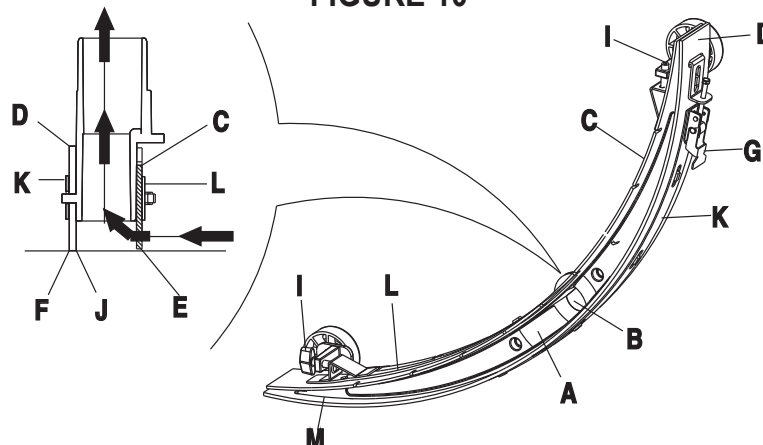

## SQUEEGEE BLADE CHECK AND REPLACEMENT

1. Following the methods related in the previous section clean the squeegee (Figure 10)
2. Check the edge (E, Figure 10) of the front squeegee blade and the edge (F) of the rear squeegee blade (D). On the whole length, they should be level. Otherwise, adjust their heights through the following procedure.
  - Loosen the clip (G) to let the rear squeegee blade (D) separate from the bracket (M) for the adjustment of the position of the squeegee. After the adjustment, lock the clip once again.
  - Loosen the screw on the handle (I) to adjust the front squeegee blade (C); tighten the handle screw after adjustment.
3. Check if the front squeegee blade (C) and the rear squeegee blade (D) is intact and if there are broken edges and cracks. If damage is found, change them according in the following way. If the front edge of the rear squeegee blade (J) has worn, it can be flipped upside down and re-installed (the top edge is required to be intact). If the top edge is also worn, change it by following the procedure below:
  - Loosen the clip (G) to let the pressure blade separate from the bracket (M), take off the clip bar (K), and then change or turn the rear squeegee blade (D) upside down. Re-install the rear squeegee blade in the reverse order of taking it off.
  - Loosen the handle screw (I) and take off the front clip bar (L), and then change the front squeegee (C). Re-install the front squeegee blade in the reverse order of taking it off. After changing the squeegee blade, adjust the level of the front and rear squeegee blades in the procedures as described above.
4. Connect the Vacuum hose (11) to the squeegee.
5. Install the squeegee and tighten the knobs.
6. If necessary, adjust the squeegee by turning the adjustment knob (20) (refer to the procedures for adjusting the balance of the squeegee).

## BRUSH/ PAD CLEANING

### CAUTION !

When cleaning the brush/pad-driver, wearing protective gloves is recommended as the brush / pad may contain sharp debris.

1. Remove the brush/pad-driver.
2. With the use of water and detergents, clean the brush/pad driver.
3. Check the brush for wear & if necessary, replace the brush.
4. Check the pad driver for wear & if necessary, replace the pad driver.
5. Remove and clean the rear squeegee and check for wear, nicks or tears, replace as required.

## WATER TANK AND FLOAT FILTER MESH CLEANING

1. Move the machine to a dedicated draining area.
2. Press the power switch (38) to the position "O" to turn off the machine.
3. Open recovery tank lid (A, Figure 11), and remove the float device (36) from inside the tank.
4. Use clean water to rinse the recovery tank lid (A), the tank (B and C), and the float filter support frame (E). Drain all the water from the water tank.
5. If necessary, following the symbols "Open" and "Close" as shown in Figure 11, open the bottom lid (F) of the float filter and clean the float (D), float filter support frame (E), and the filter sponge (I). After cleaning, re-attach the float onto the support frame (E), and then align the mark groove (L) of the bottom lid (F) of the float filter with the mark groove (L) of the float filter support frame (E). Turn the bottom lid (F) of the float filter tight, and re-attach the filter sponge (I) onto the support frame (E), and then onto the vacuum tube (M).
6. Inspect the seal / gasket (G) of the recovery tank lid. If necessary, the recovery tank seal / gasket (G) may be taken out from the groove (H) and changed. When installing the new seal / gasket as shown in Figure 11 below, install the connector to the middle section of the rear part.

### NOTE

The seal / gasket (G) of the recovery tank allows the tank to create a vacuum. It must be completely sealed to be able to effectively suck the wastewater from the floor.

7. Check if the receiving surface of the sealing strip (G) is intact and seals adequately.
8. Close recovery tank lid (A).

FIGURE 11

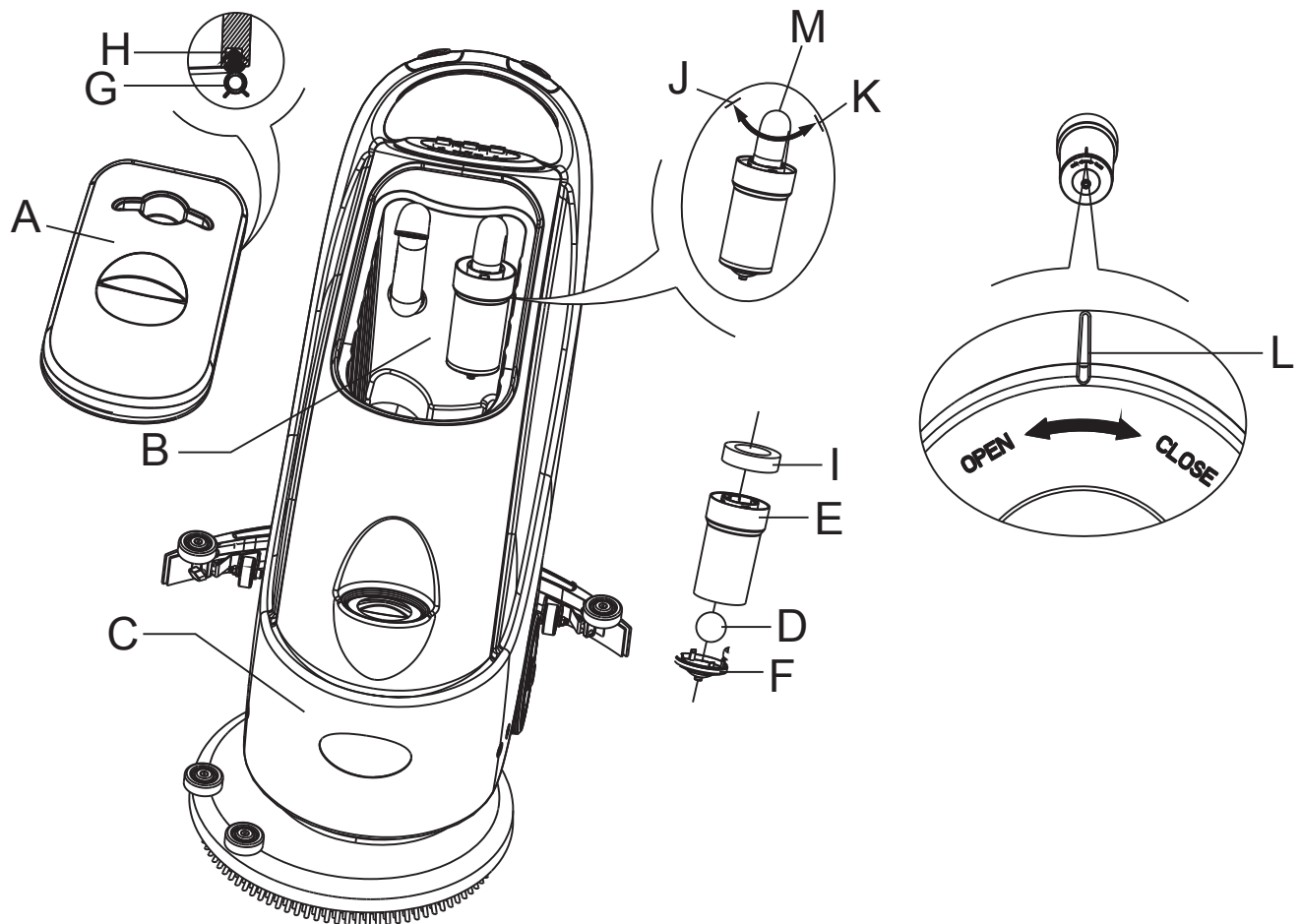

## SOLUTION FILTER CLEANING

1. Drain all the water from Solution tank as previously outlined.
2. Move the machine to a flat and smooth surface.
3. Press the power switch (38) to the "O" position to turn off the machine.
4. Turn off the draining ball valve (A, Figure 12) (located at the bottom of the machine, behind the wheels). Position B ball valve open, and position C ball valve closed.
5. Remove the transparent cap (D), and then take off the filter (E), and install them onto the filter box (F) after cleaning.

### NOTE

The filter (E) must be accurately installed onto the position of the housing (G).

6. Open the draining ball valve (A).

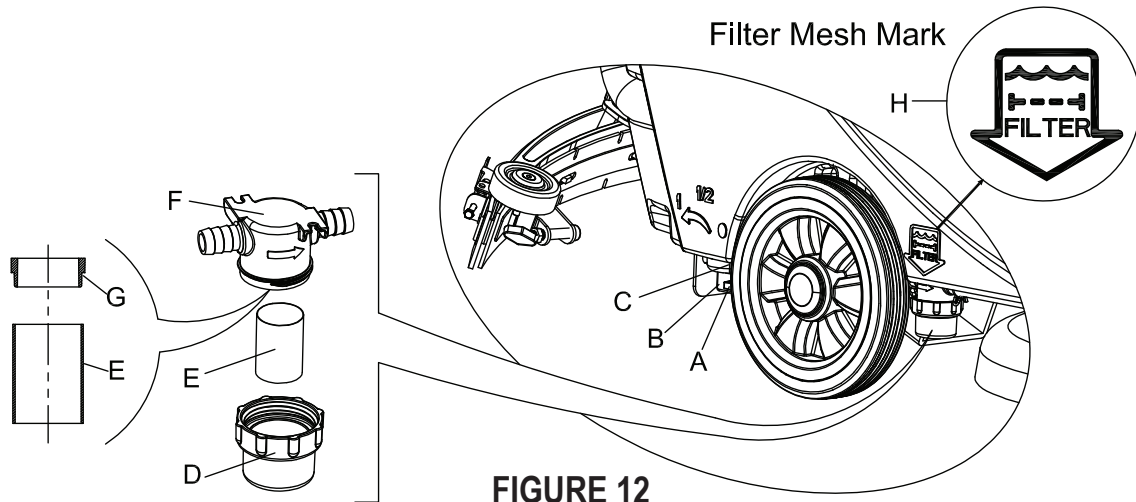

FIGURE 12

## TROUBLESHOOTING

For anything not covered in this table, please contact an authorized service center

Breakdown	Probable Cause	Remedies
Machine not working	The wiring not connected correctly or bad	Check the wiring
Vacuum motor not working	The wiring not connected correctly or bad wiring	Check the wiring
Little or no solution flow	Ball valve position in need of adjustment	When ball valve is in horizontal position, the amount of solution flow is maximum
	Filter dirty	Clean the filter
Inadequate Vacuum	Recovery tank is full.	Drain the recovery tank
	Drain hose and squeegee hose not properly connected	Connect the drain hose and the squeegee hose
	Float filter blocked or inlet blocked	Clean the float filter, check the float ball
	Squeegee dirty or squeegee blade worn and damaged	Clean and check the squeegee
	Recovery tank lid not properly sealed, or the seal / gasket for recovery tank damaged	Refit on the lid properly, replace the recovery tank seal / gasket
Squeegee leaving marks	Debris fragments under the squeegee blade	Remove the fragments
	Squeegee blade worn, cracked or brittle.	Replace the squeegee blade
	Balance of squeegee not adjusted	Adjust the balance



TANK SYSTEM

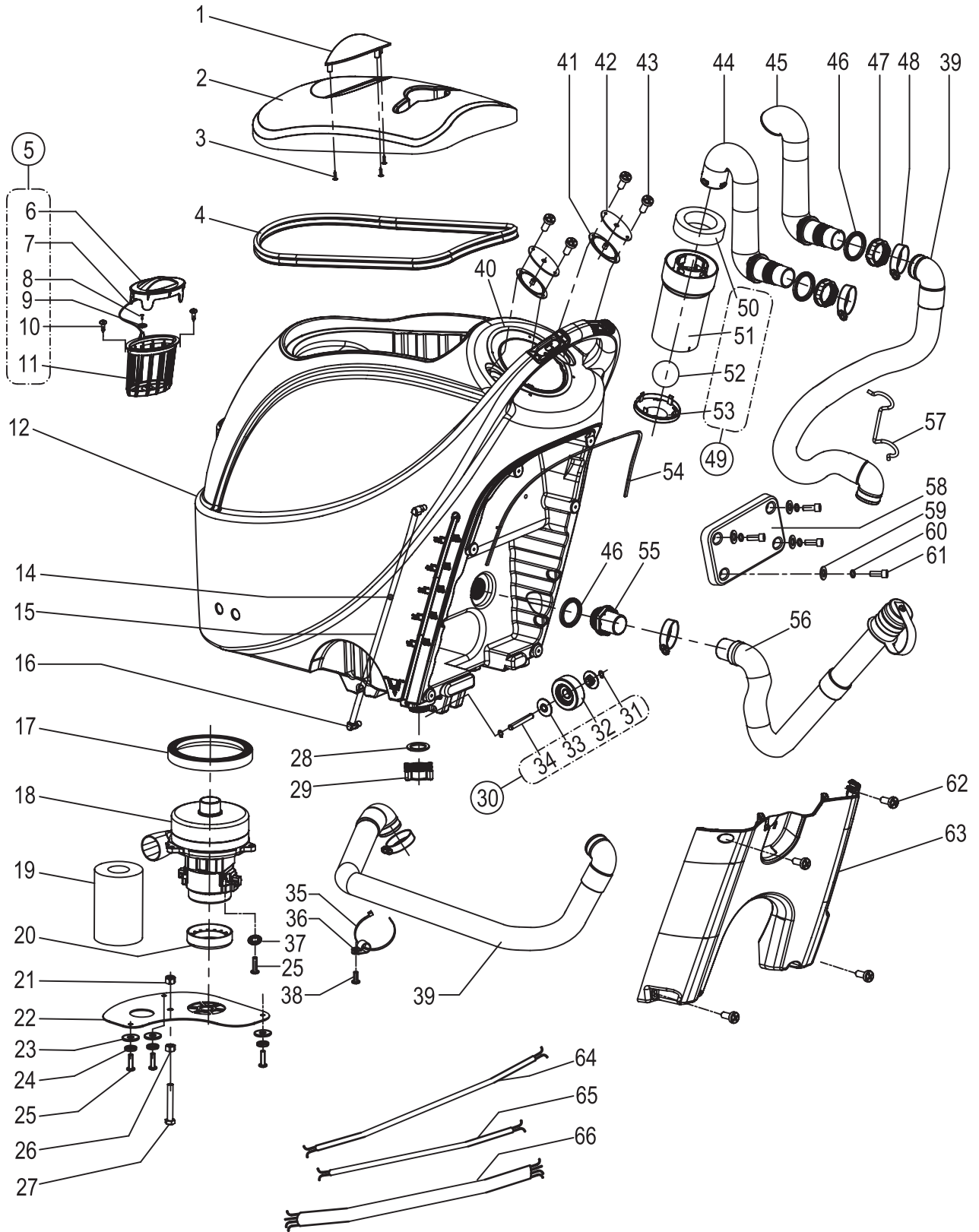



## TANK SYSTEM

Item	Ref. No.	Qty	Description	Item	Ref. No.	Qty	Description
1	VF90412A	1	Handle, Recovery Tank Cover	34	VF90314	1	Transport Wheel Shaft
2	VF90503A	1	Recovery Tank Cover	35	VV10116	1	Self-Locking Nylon Cable Ties
3	VA80758	3	Screw	36	VF85102	1	Clamp
4	VF90504	1	Gasket	37	VF13604	1	Grooved Metal Gasket
5	VF90619A	1	Tank Filter Net Kit	38	VF90235	1	Scerew Tm4x10
6	VF90612A	1	Filter Cover	39	VF90508	2	Suction Hose
7	VF90614	1	Inlet Strap	40	VF90231	1	Gasket
8	VF90616	2	Screw Ta3.5x12	41	VF90214	2	Seal Plate Cover
9	VA13483A	2	Washer	42	VF90217	2	Seal Plate
10	VA13477	2	Screw St4x15	43	VV68303	4	Screw KT3.5x15
11	VF90611	1	Filter Support	44	VF90529	1	Suction Tube Connector
12	VF90519A	1	Tank (Cable Modle)	45	VF90528	1	Drain Hose Connector
14	VF90613A	1	Floating Ball Of Water Level	46	VF90512	2	Suction Tube Gasket
15	VF90617	1	Inspection Tube	47	VF90509	2	Sealing Knob
16	RD60764	2	Elbow,90°,Brass	48	VA20304	4	Clamp
17	VA80770	1	Gasket	49	VF90534	1	Float Kit
18	VF90727	1	Vacuum Motor	50	VF90530	1	Cage,Float Complete
19	VF85319	1	Acoustic Insulation Pipe	51	VF90526	1	Float Bracket
20	VF90523	1	Top Gasket Of Suction Motor	52	VF85124	1	Floate
21	VF13503	1	Nut Lock M8	53	VF90527	1	Floate Bracket Cover
22	VF90511	1	Cover, Vacuum Motor	54	VF90218	1	Control Seal Gasket
23	VF14543	3	Washer Ø6Ø18*1.5	55	VF90401	1	Drain Hose Connector
24	VV13601	3	Washer,Lock,Ø5	56	VF90443	1	Drain Hose-38
25	VA52245	4	Scerew M5*15	57	VF83150	1	Holder,"U"Hose
26	VF14066	1	Nut M8	58	VF90701	1	17"Counter Weight Block
27	VF90434	1	Scerew M8*65	59	VF13534	4	Washer
28	VF90513	1	Outlet O-Ring	60	VF13519	4	Washer,Lock,Ø8
29	VF90507	1	Outlet Cover	61	VF14067	4	Screw M8*25
30	VF90312	1	2.5" Wheel Kit	62	GT13054	4	Scerew Tm5x12
31	VF14551	2	Ring D 17	63	VF90814A	1	Battery Covery
32	VF90306	1	2.5" Wheel	64	VF90720	1	Vacuum Motor Connection Line
33	VF90308	2	2.5" Hub Cap	65	VF90730	1	Solenoid Valve Connection Line
				66	VF90721	1	Brush Motor Connection Line

CONTROL SYSTEM AND ELECTRICAL SYSTEM

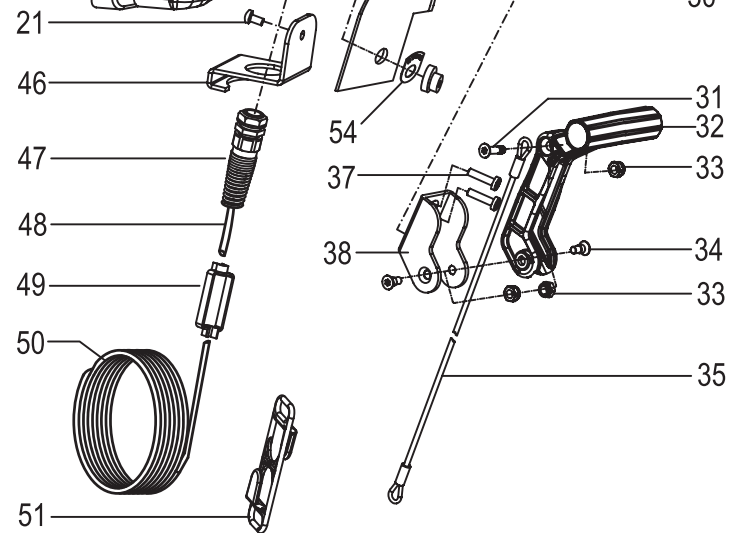
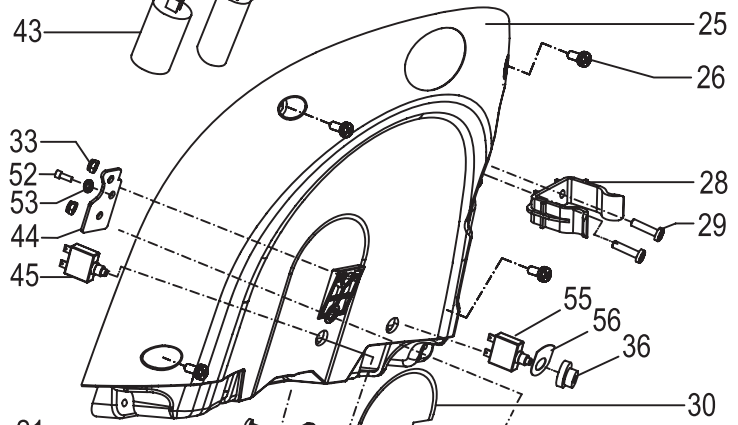
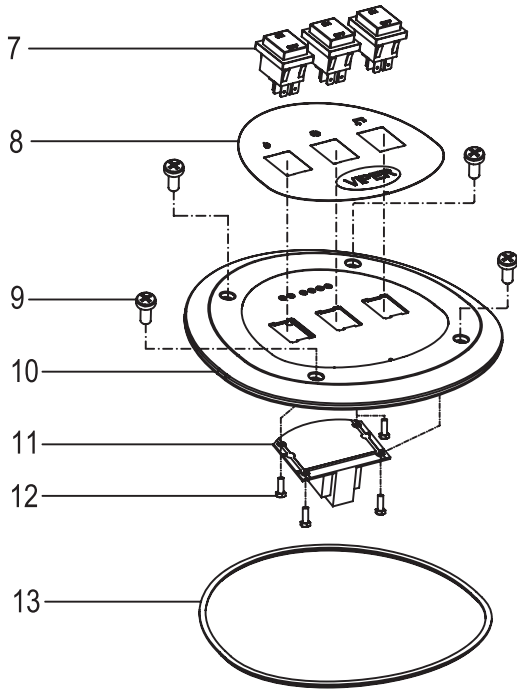
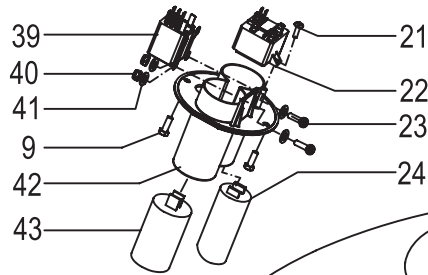
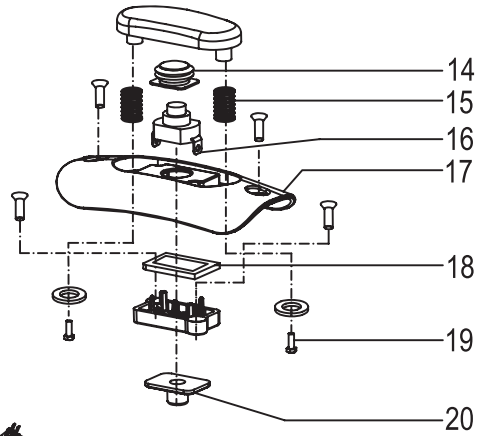
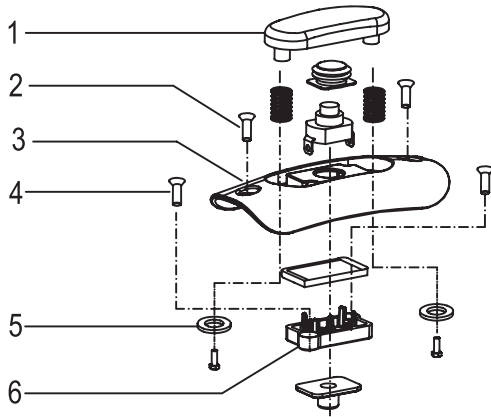

## CONTROL SYSTEM AND ELECTRICAL SYSTEM

Item	Ref. No.	Qty	Description	Item	Ref. No.	Qty	Description
1	VF90203A	2	Safety Switch Knob	28	GV70034	1	Clamp Drain Hose
2	VF90286	4	Screw KA3.5x12	29	VF14538	2	SCREW ST3.5x16
3	VF90201A	1	Safety Switch Cover Left	30	VF90027-CL	1	Back Cover Panel
4	VV68303	4	Screw KA3.5x15	31	VF90129	1	Screw M5x20
5	VF90288	4	Washer $\Phi 3.6 \times \phi 8 \times 0.5$	32	VF90113	1	Handle Lift
6	VF90210A	2	Switch Fix Frame	33	VF14514	5	Nut Lock M5
7	VV60153	3	Switch RI2 (P)	34	VF90128	2	Screw M5
8	VF90009-CL	1	Decal Control Panel	35	VF90114	1	Cable Squeegee Lift
9	VF90235	6	Screw Tm4x10	36	VF89076	2	Circuit Breaker Cap
10	VF90204A	1	17" Switch Cover	37	80407A	2	Screw M5x25
11	VF90706	1	24vdc Regulator Board	38	VF90116	1	Hand Bracket
12	VA14584	4	SCREW PB3.0x8	39	VF90704	1	24v Relay
13	VF90285	1	Switch Seal Strip	40	VV13652	2	Nut Lock M3
14	VF90216	2	Switch Seal Bushing	41	VV13653	4	Washer $\Phi 3.4 \times \phi 10 \times 1.0 \text{mm}$
15	VF90202	4	Spring	42	VF90232	1	Electric Support
16	VF90252	2	Switch	43	VF90725-2	1	Start Capacitor
17	VF90212A	1	Safety Switch Cover Right	44	VF90259	1	Hand Fix Panel
18	VF90219	2	Gasket	45	VF99010C	1	Circuit Breaker
19	VA13469	4	Screw Pb3x12	46	VF90517	1	Cable Fix Bracket
20	VF90213	2	Switch Seal Ring	47	VF73705	1	Cable Sleeve
21	GT13091	2	Screw,PB3.5x9.5mm	48	VF90745	1	Power Cord
22	VF89042-3	1	Relay	49	VV67105	1	Connector
23	GT13025	2	Screw,M3x12	50	VF90703-US	1	Cable (20m)
24	VF90725-1	1	Running Capacitor	51	VF422997	1	Hanging Board
25	VF90815A	1	Cover Control Housing	52	VF13667	1	Screw M4x8
26	GT13054	4	Screw Tm5x12	53	VF13604	1	Grooved Metal Gasket
				54	VF90019	1	Brush Circuit Label
				55	VF90747	1	Circuit Breaker
				56	VF90020	1	Vacuum Circuit Label

### WHEELS AND SOLUTION SYSTEM

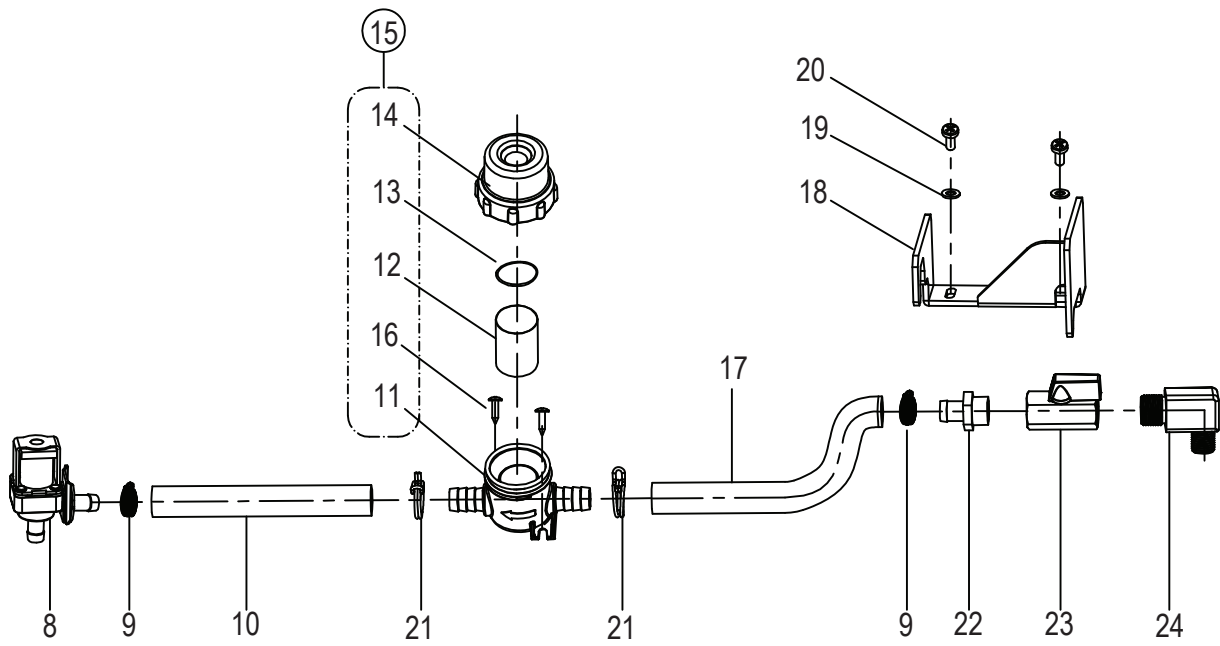
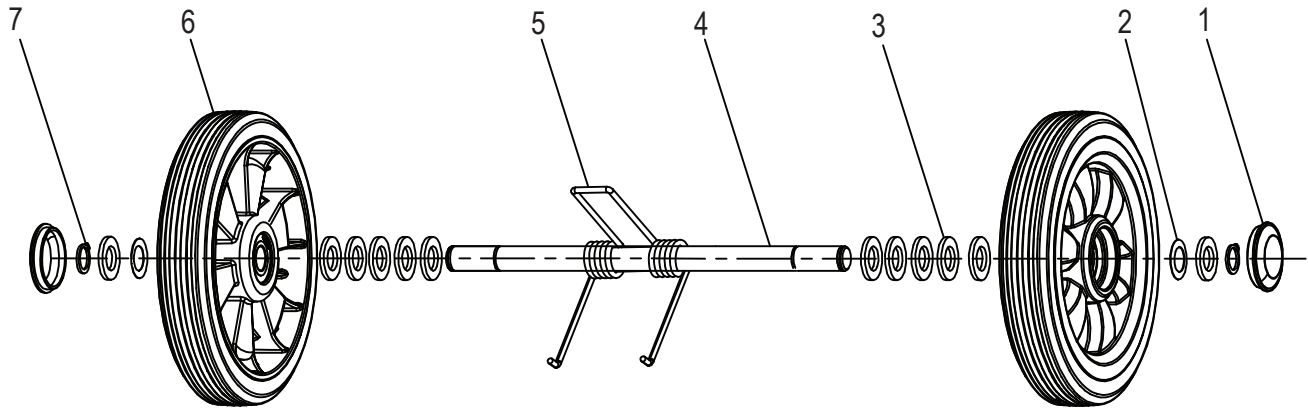

**WHEELS AND SOLUTION SYSTEM**

<b>Item</b>	<b>Ref. No.</b>	<b>Qty</b>	<b>Description</b>
1	VF89203	2	Wheel Cover
2	VF14563	2	Leville Washer
3	VF14554	12	Washer
4	VF90304	1	Wheel Shaft
5	VF82172	1	Spring 70°
6	VF90305	2	8" Wheel
7	VF14552	2	Ring D 17
8	VF90284	1	Solenoid Valve Kit
9	VV10114	2	Clamp
10	VF90440	1	Tubing L=260mm
11	VF90604	1	Filter Base
12	VF90608	1	Filter Net
13	VF90607	1	O-Ring
14	VF90603	1	Filter Cover
15	VF90621	1	Filter Kit
16	VA13507	2	Screw St4x12
17	VF90441	1	Tubing L=160mm
18	VF90625	1	Solenoid Valve Bracket
19	VA13483	2	Washer $\Phi 4 \times \Phi 12.5 \times 1.5$
20	VV13650A	2	Screw M4x10
21	VF82148	2	Clamp, Hose
22	VF80313	1	Barb, Hose
23	VF80361	1	Ball Valve
24	VF90609	1	Elbow,90°,Brass

BRUSH SYSTEM

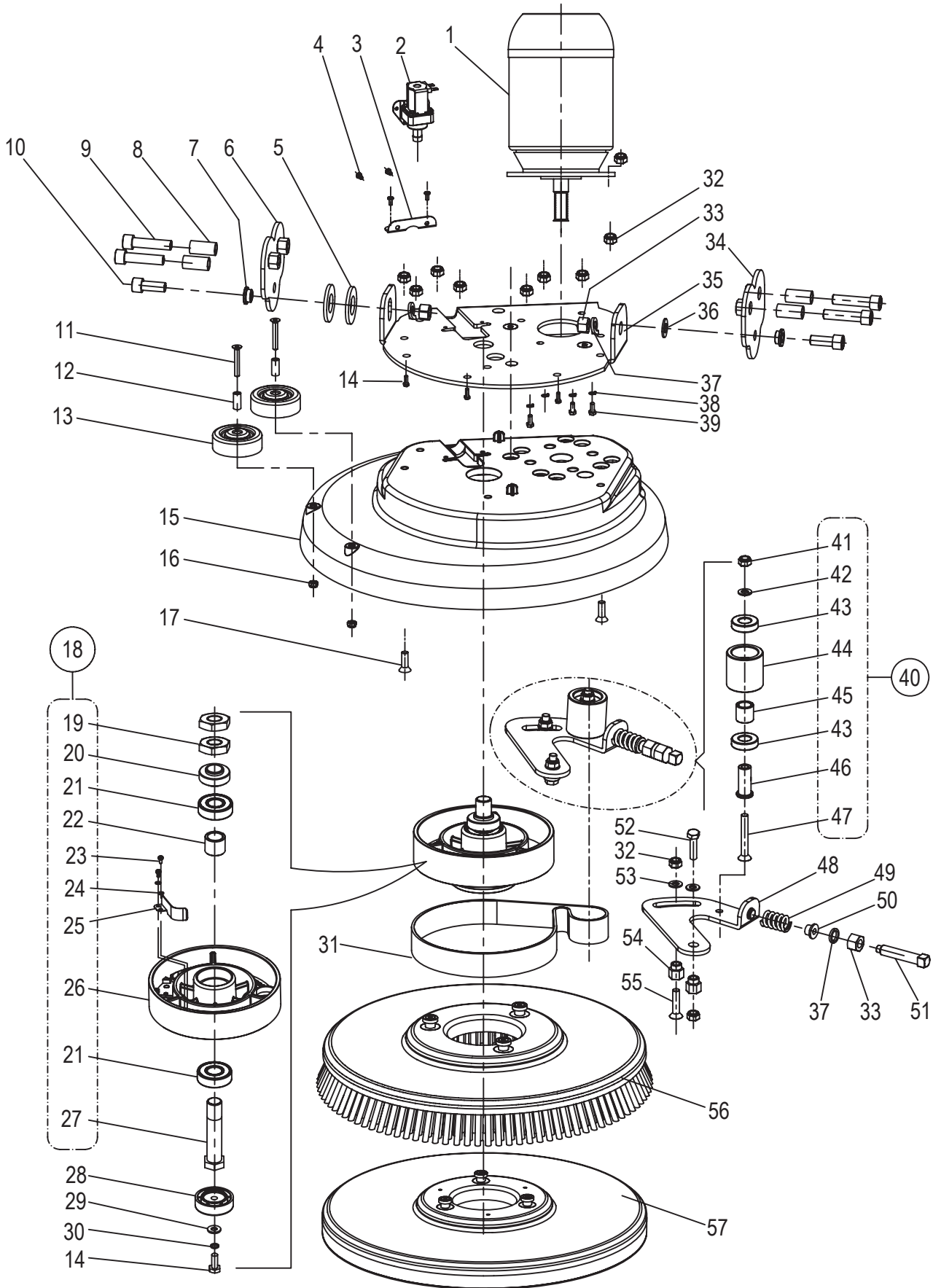

## BRUSH SYSTEM

Item	Ref. No.	Qty	Description	Item	Ref. No.	Qty	Description
1	VF90729	1	Brush Motor Kit	28	VF90415	1	Vibration Gasket
2	VF90284	1	Solenoid Valve Kit	29	VF13534	1	Washer Ø8.4x Ø18x 2
3	VF90418	1	Solenoid Valve Bracket	30	VV20298	1	Washer,Lock,Ø8
4	VV13650A	4	Screw M4x10	31	VF90462	1	Belt
5	VV20274	2	Washer	32	VF13503	9	Nut Lock M8
6	VF90460	1	Connect Plate C	33	VF14057A	3	Nut Lock M12
7	VF90461	2	Brass Spacer B	34	VF90459	1	Sliding Connect Plate
8	VF90421	4	Spacer	35	VF90455	1	Frame
9	VF14555	4	Screw, Shoulder M12x50	36	VF13538	1	Washer Ø12xØ24x2
10	VF14238	2	Screw, M12x30	37	VF13541	3	Washer,Lock Ø12
11	VF14530	2	Screw, Shoulder M6x40	38	VV20298	4	Washer,Lock,Ø8
12	VF85134	2	Spacer	39	VA13491	3	Screw, M8x25
13	VF85107	2	Bumper Roller	40	VF90445	1	Tension Wheel Kit
14	VV13604	4	Screw, Shoulder M8x20	41	VF14516	1	Nut Lock M8
15	VF90406A	1	17" Brush Deck	42	VF13535	1	Washer Ø8xØ20x2
16	VF14506	2	Nut Lock M6	43	VF999821A	2	Bearing 6002
17	GT13067	2	Screw, Shoulder M8x25	44	VF90426	1	Tension Wheel
18	VF90465	1	Driven Pulley Kit	45	VF80209	1	Spacer
19	VF90424	2	Nut M20	46	VF80214	1	Spacer
20	VF90422	1	Spacer	47	GT13066	1	Screw, Shoulder M8x55
21	ZD45425	2	Bearing 6204 Lu	48	VF90427	1	Rod, Tension Wheel
22	VF90423	1	Clamp Sleeve	49	VF80232	1	Spring
23	VV13650A	2	Screw M4x10	50	VF80235	1	Spacer
24	VV20291	2	Washer,Lock,Ø4	51	VF14255	1	Screw, M12x65
25	VF90437	1	Brush Spring Clip	52	VF14236	1	Screw, M8x40
26	VF90463	1	Driven Pulley	53	VF13534	2	WASHER Ø8.4x Ø18x 2
27	VF90425	1	Driven Pulley Shaft	54	VF90439	2	Bushing Tension Wheel
				55	VF90438	1	Screw, Shoulder M8x30
				56	VF90411	1	17" Brush
				57	VF90453	1	17" Pad

### SQUEEGEE SYSTEM

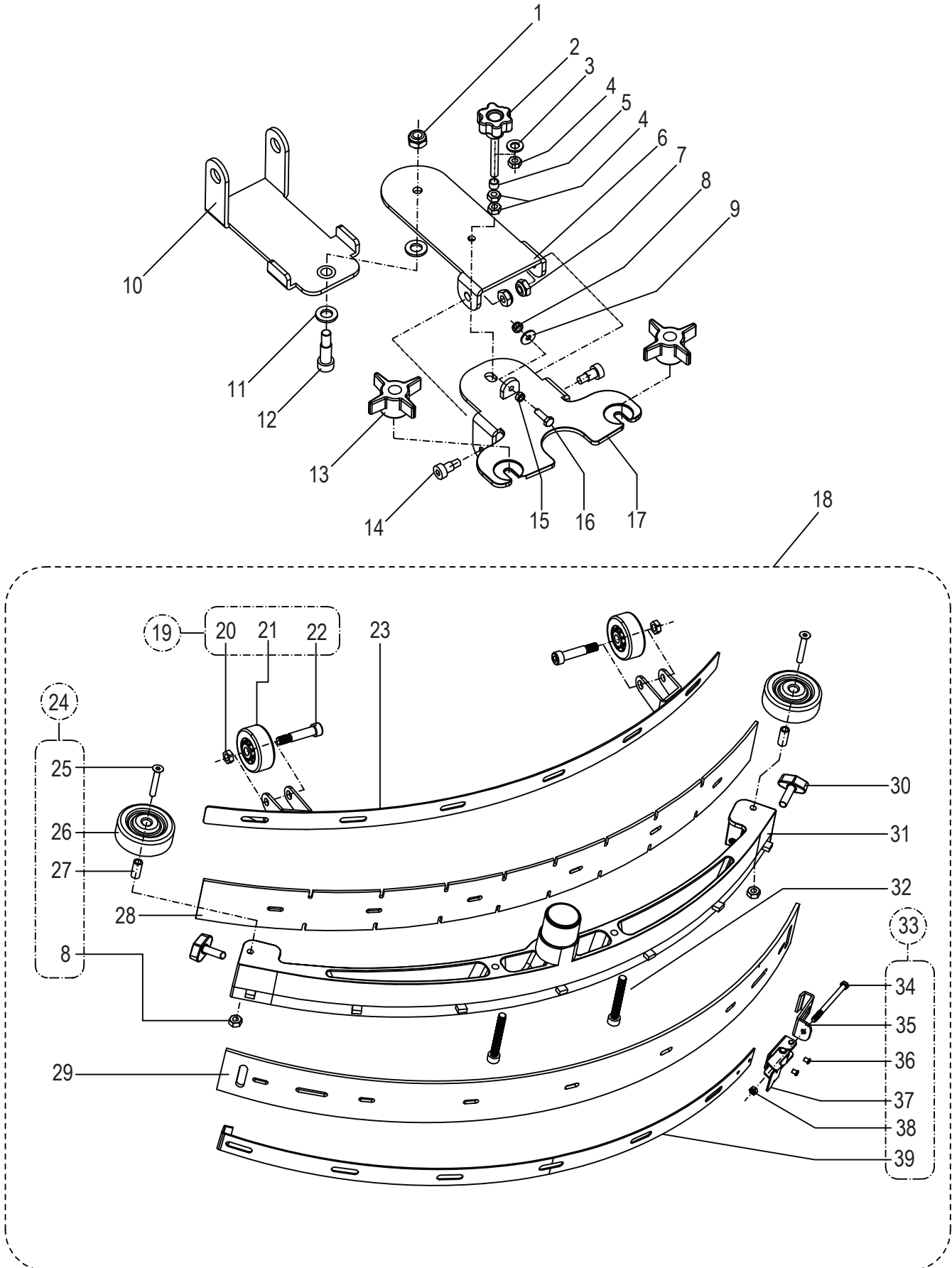



## SQUEEGEE SYSTEM

Item	Ref. No.	Qty	Description
1	VF14547	1	Screw Lock M10
2	VF85104	1	Hand Wheel
3	VF13534	1	Washer $\Phi 8.4 \times \Phi 18 \times 2$
4	VF14503	3	Nut M8
5	VF90133	1	Spacer
6	VF90110	1	Back-Squeegee-Support
7	VF14516	2	Nut Lock M8
8	VF14506	3	Nut M6
9	VF13533	1	Washer Flat $\Phi 6$
10	VF90111	1	Front-Squeegee-Support
11	VF85336	2	Washer Nylon
12	VF90130	1	Screw Shoulder
13	VF81210	2	Knob
14	VF84228	2	Screw Shoulder M8
15	VF82112	1	Spacer
16	VF14233	1	Screw
17	VF90109	1	Squeegee-Support
18	VF90134	1	17" Squeegee Kit
19	VF90136	2	Squeegee Roll Wheel Kit
20	VV20203	2	Nut Lock
21	VF81219	2	2" Wheel
22	VF81222	2	Bolt Shoulder 5/16"
23	VF90102	1	17" Strap, Squeegee Front
24	VF90137	2	Bumper Roller Kit
25	VF14530	2	Screw M6 $\times$ 40
26	VF85107	2	Bumper Roller
27	VF85134	2	Spacer
28	VF90103	1	17" Blade Front
29	VF90104	1	17" Blade Rear
30	VF85420	2	Wing Nut M8 $\times$ 30
31	VF90101	1	Squeegee 17"
32	VF90127	2	Squeegee Screw
33	VF90138	1	17" Strap, Squeegee Back Kit
34	VF14305	1	Screw M5 $\times$ 60
35	VF90121	1	Hook
36	VF81208A	2	Rivet $\Phi 4 \times 5$
37	VF81218A	1	Latch Hood
38	GT13022	1	Nut Lock M5
39	VF90105	1	17" Strap, Squeegee Back

# WIRING DIAGRAM

