

# SC750, SC800

## SC750 ST, SC800 ST

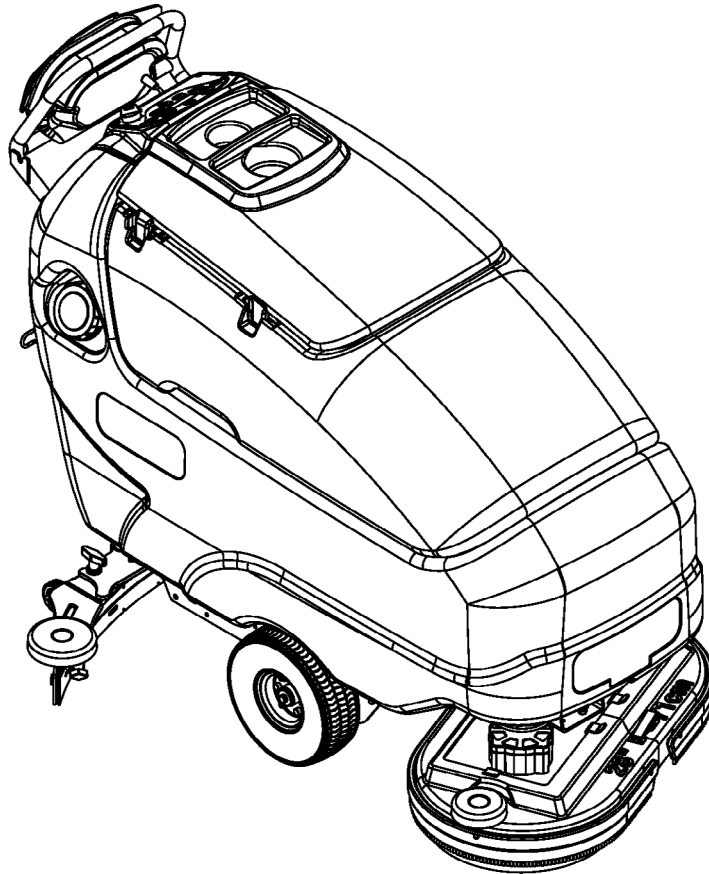

### **PARTS LIST**

**Advance Models: 56112000(SC750-26D), 56112004(SC750-28D)  
56112006(SC750-28C), 56112012(SC750 ST-26D)  
56112013(SC750 ST-28C), 56112016(SC800-28D)  
56112018(SC800-28C), 56112024(SC800-32C)  
56112028(SC800-34D), 56112032(SC800 ST-34D)**

<u>DESCRIPTION</u>	<u>PAGE</u>
Battery Charger System .....	3
Chassis System (Disk).....	4-5
Chassis System (Cylindrical) .....	6-7
Chemical Injection System (EcoFlex™) .....	8
Control System (SC750, SC800).....	9
Control System (SC750 ST, SC800 ST) .....	10
Decal System.....	11
Electrical System (SC750, SC800).....	12-13
Electrical System (SC750 ST, SC800 ST) .....	14-15
Recovery System.....	16-17
Scrub System-Disk .....	18-19
Scrub System-Cylindrical.....	20-21
Solution System.....	22
Squeegee Assembly .....	23
Squeegee System .....	24-25
Ladder Diagram (SC750, SC800).....	26-27
Ladder Diagram (SC750 ST, SC800 ST).....	28-29
Optional Kits & Accessories.....	30
Brush Selector Guide-Disk .....	31
Brush Selector Guide-Cylindrical .....	32
Squeegee Blade Selector Guide .....	33

**WHEN ORDERING PARTS**

- \* Use the part numbers from the "Ref. No." columns in this parts list.
- \* Specify the model and serial number of the machine.
- \* Use the space below to record the model and serial number for future reference.

Model \_\_\_\_\_ Serial No. \_\_\_\_\_

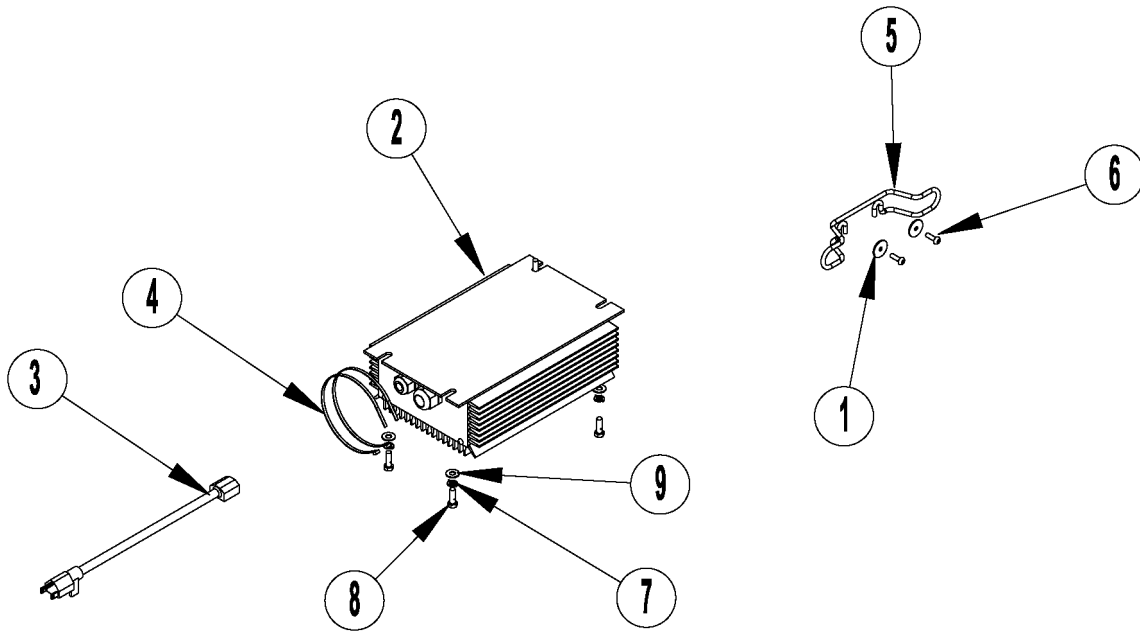

Item	Ref. No.	Qty	Description
1	56009096	2	Wsh, Flt .193 X .875 X .060
2	56112243	1	Battery Charger 24V 25A (A3)
3	56315270	1	Charger Cord, Us
4	56478523	2	Tie, Cable
5	9095149000	1	Cable Support
6	964004	2	Screw M5-.8 X 16mm Pn St Ph
7	980657	4	Washer, Lock 1/4
8	57994a	4	Screw, M6- 1 X 20
9	87026a	4	Washer, 1/4 Flat S.S.

# CHASSIS SYSTEM (DISK)

10-7

4

SC750, SC800, SC750 ST, SC800 ST

2010-10

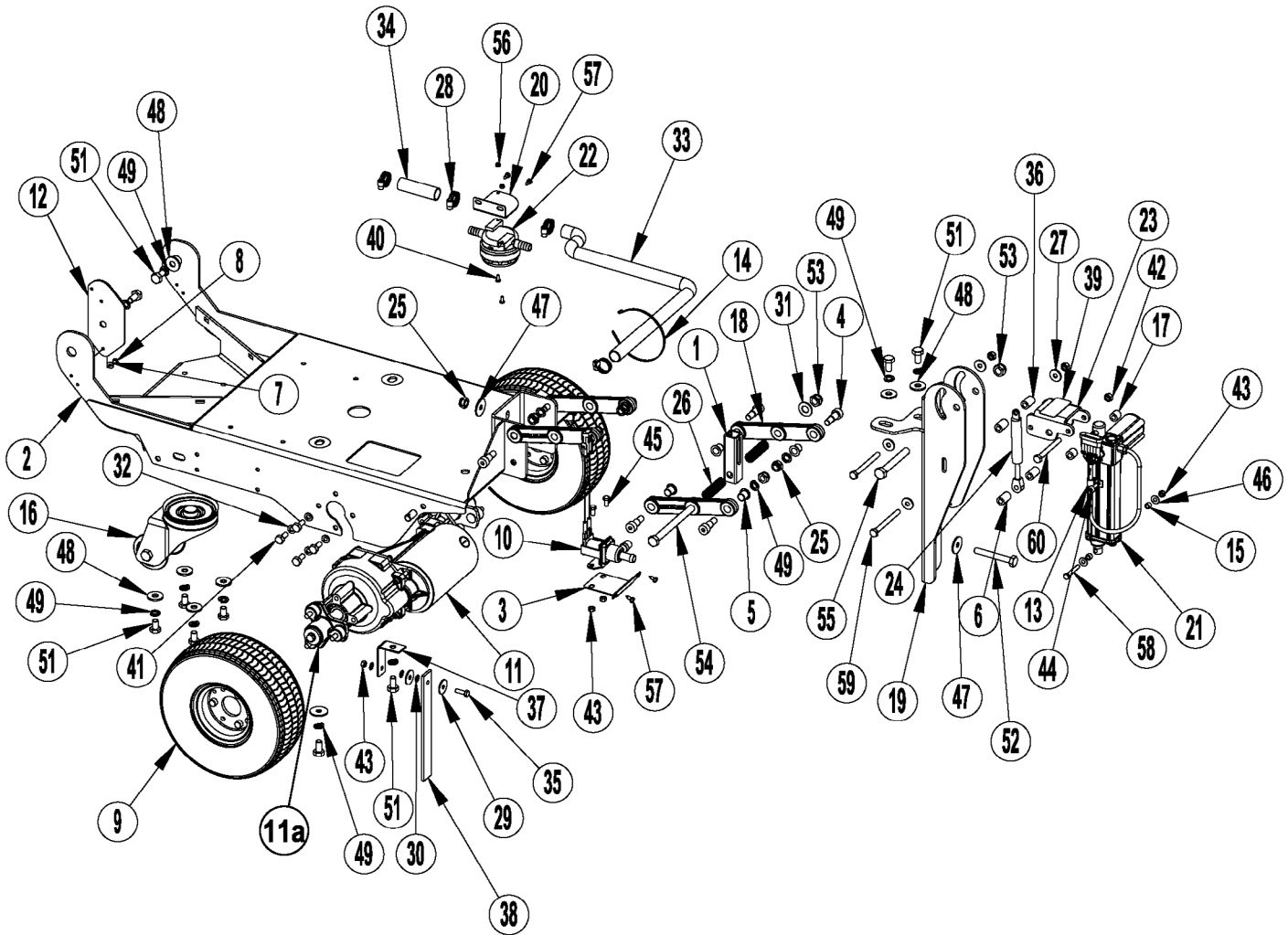

Item	Ref. No.	Qty	Description	Item	Ref. No.	Qty	Description
1	56109717	1	Tube Jack Motor	31	980648	1	Washer 17/32 X 1 1/16 Plain
2	61931a	1	Chassis, Wldmt.	32	980652	8	Washer, 5/16 Lock
3	61932a	1	Bracket, Solution Valve	33	30828a	1	Hose, Clear X25.00 Long
4	88617a	8	Screw, M10xm12x16mm S.B.S.H.	34	30829a	1	Hose, Clear X 3.00 Long
5	88647a	8	Bushing, Flanged	35	57994a	1	Screw, M6- 1 X 20
6	9096113000	2	Spacer	36	61937a	2	Spacer, .590od X .328id
7	56001954	1	Wsh, Flt Sae #10	37	61949a	1	Bracket, Ground Strap
8	56009030	1	Scr, Pan Phil Thd Form 10-24 X .38	38	69639a	1	Strap, Static
9	56112109	2	Tire	39	71017a	1	Label, Moving Parts
10	56112147	1	Solenoid Valve Assy (L1)	40	80057a	2	Screw, M4-.7x10
11	56112343	1	Transaxle	41	80183a	8	Bolt, M8-1.25 X 20, Hex
11a	56380158	2	Flange Kit	42	80198a	9	Nut, M8 -1.25 Nylock S.S.
*	50981A	1	Motor-Transaxle (M1)	43	80199a	4	Nut, M6 -1.00 Nylock S.S.
*	40628A	4	Carbon Brush	44	80208a	1	Screw, M6 X 1.00 X 10mm Pan Head
12	56112281	1	Connector Bracket	45	80214a	2	Screw, M6 X 1 X 12
13	56323260	1	Clamp, Hose Support	46	87026a	2	Washer, 1/4 Flat S.S.
14	56478523	1	Tie, Cable	47	87054a	3	Washer Fender .375
15	1462258000	2	Spacer 6.1 X 10 X 6.5	48	88611a	7	Washer, Flat M10
16	56112308	1	Caster, Rear	49	88612a	18	Washer, Lock M10
17	9096112000	2	Spacer	50#			<b>DELETED</b>
18	9097197000	4	Lever, Brush Head Lift	51#	88614a	10	Screw, M10-1.5 X 20mm
19	9097368000	1	Support, Jack Motor	52	88616a	1	Screw, Hex Hd M10x75
20	9097370000	1	Bracket, Filter	53	88618a	2	Nut, M12 Nylon Insert
21	40280A	1	Actuator (M2)	54	88619a	1	Screw, Hex Hd M12x160
22	9097404000	1	Filter, Water	55	88620a	1	Screw, Hex Hd M12x90
*	9095215000	1	Filter and Seal	56	88623a	2	Nut, M4-.7 Nylock Insert
23	9097456000	1	Lever	57	88624a	4	Screw, M5 X 12mm Hex Self Tap Tri-Lobe
24	54689a	1	Gas Spring 500n	58	88626a	1	Screw M6-1 X 40mm Hex
25	80223a	9	Nut, M10-1.5 Nylock	59	88633a	2	Screw, M8 X 85 Hex Head
26	E04016	2	Spring	60	88635a	1	Screw, M8 X75 Hex Head
27	170860	4	Washer, Flat 5/16				
28	722030	4	Clamp, Hose				
29	980205	2	Washer, .31 I.D. X 1.06 O.D.				
30	980614	3	Washer, 1/4" Starlock, External				

\* = Optional, Not Included

# = Revised or new since last update

CHASSIS SYSTEM (CYLINDRICAL)

10-7

6

SC750, SC800, SC750 ST, SC800 ST

2010-10

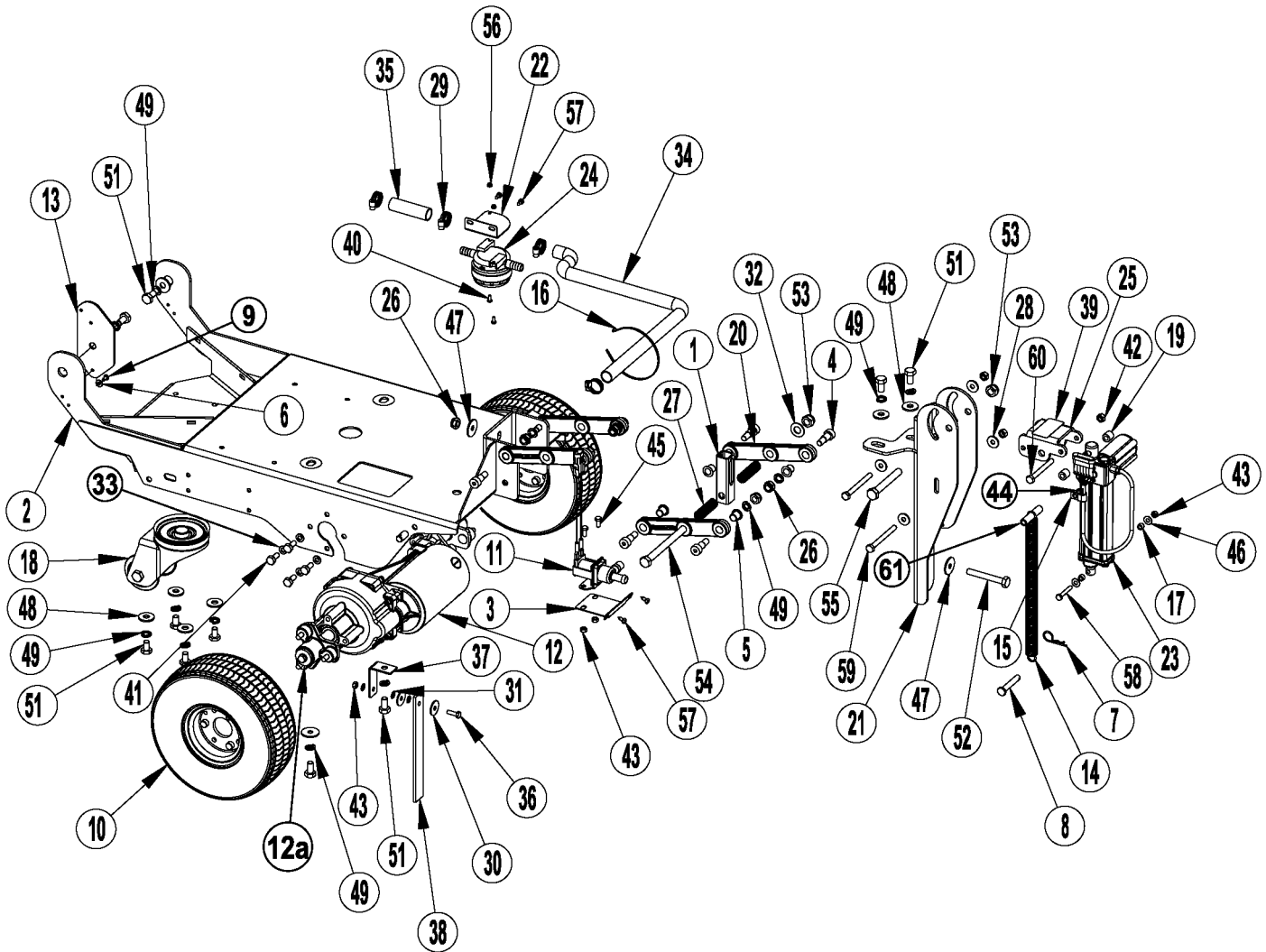

Item	Ref. No.	Qty	Description	Item	Ref. No.	Qty	Description
1	56109717	1	Tube Jack Motor	31	980614	3	Washer, 1/4" Starlock, External
2	61931a	1	Chassis, Wldmt.	32	980648	1	Washer 17/32 X 1 1/16 Plain
3	61932a	1	Bracket, Solution Valve	33	980652	8	Washer, 5/16 Lock
4	88617a	8	Screw, M10xm12x16mm S.B.S.H.	34	30828a	1	Hose, Clear X25.00 Long
5	88647a	8	Bushing, Flanged	35	30829a	1	Hose, Clear X 3.00 Long
6	56001954	1	Wsh, Flt Sae #10	36	57994a	1	Screw, M6- 1 X 20
7	56002959	1	Pin, Cotter Hair	37	61949a	1	Bracket, Ground Strap
8	56003656	1	Pin-Clevis .375 X 2.25	38	69639a	1	Strap, Static
9	56009030	1	Scr, Pan Phil Thd Form 10-24 X .38	39	71017a	1	Label, Moving Parts
10	56112109	2	Tire	40	80057a	2	Screw, M4-.7x10
11	56112147	1	Solenoid Valve Assy (L1)	41	80183a	8	Bolt, M8-1.25 X 20, Hex
12	56112343	1	Transaxle	42	80198a	9	Nut, M8 -1.25 Nylock S.S.
12a	56380158	2	Flange Kit	43	80199a	4	Nut, M6 -1.00 Nylock S.S.
*	50981A	1	Motor-Transaxle (M1)	44	80208a	1	Screw, M6 X 1.00 X 10mm Pan Head
*	40628A	4	Carbon Brush	45	80214a	2	Screw, M6 X 1 X 12
13	56112281	1	Connector Bracket	46	87026a	2	Washer, 1/4 Flat S.S.
14	56112282	1	Extension Spring-.81x12.0	47	87054a	3	Washer Fender .375
15	56323260	1	Clamp, Hose Support	48	88611a	7	Washer, Flat M10
16	56478523	1	Tie, Cable	49	88612a	18	Washer, Lock M10
17	1462258000	2	Spacer 6.1 X 10 X 6.5	50#			<b>DELETED</b>
18	56112308	1	Caster, Rear	51#	88614a	10	Screw, M10-1.5 X 20mm
19	9096112000	2	Spacer	52	88616a	1	Screw, Hex Hd M10x75
20	9097197000	4	Lever, Brush Head Lift	53	88618a	2	Nut, M12 Nylon Insert
21	9097368000	1	Support, Jack Motor	54	88619a	1	Screw, Hex Hd M12x160
22	9097370000	1	Bracket, Filter	55	88620a	1	Screw, Hex Hd M12x90
23	40280A	1	Actuator (M2)	56	88623a	2	Nut, M4-.7 Nylock Insert
24	9097404000	1	Filter, Water	57	88624a	4	Screw, M5 X 12mm Hex Self Tap Tri-Lobe
*	9095215000	1	Filter and Seal	58	88626a	1	Screw M6-1 X 40mm Hex
25	9097456000	1	Lever	59	88633a	2	Screw, M8 X 85 Hex Head
26	80223a	9	Nut, M10-1.5 Nylock	60	88635a	1	Screw, M8 X75 Hex Head
27	E04016	2	Spring	61	56112520	1	Spacer
28	170860	4	Washer, Flat 5/16				
29	722030	4	Clamp, Hose				
30	980205	2	Washer, .31 I.D. X 1.06 O.D.				

\* = Optional, Not Included

# = Revised or new since last update

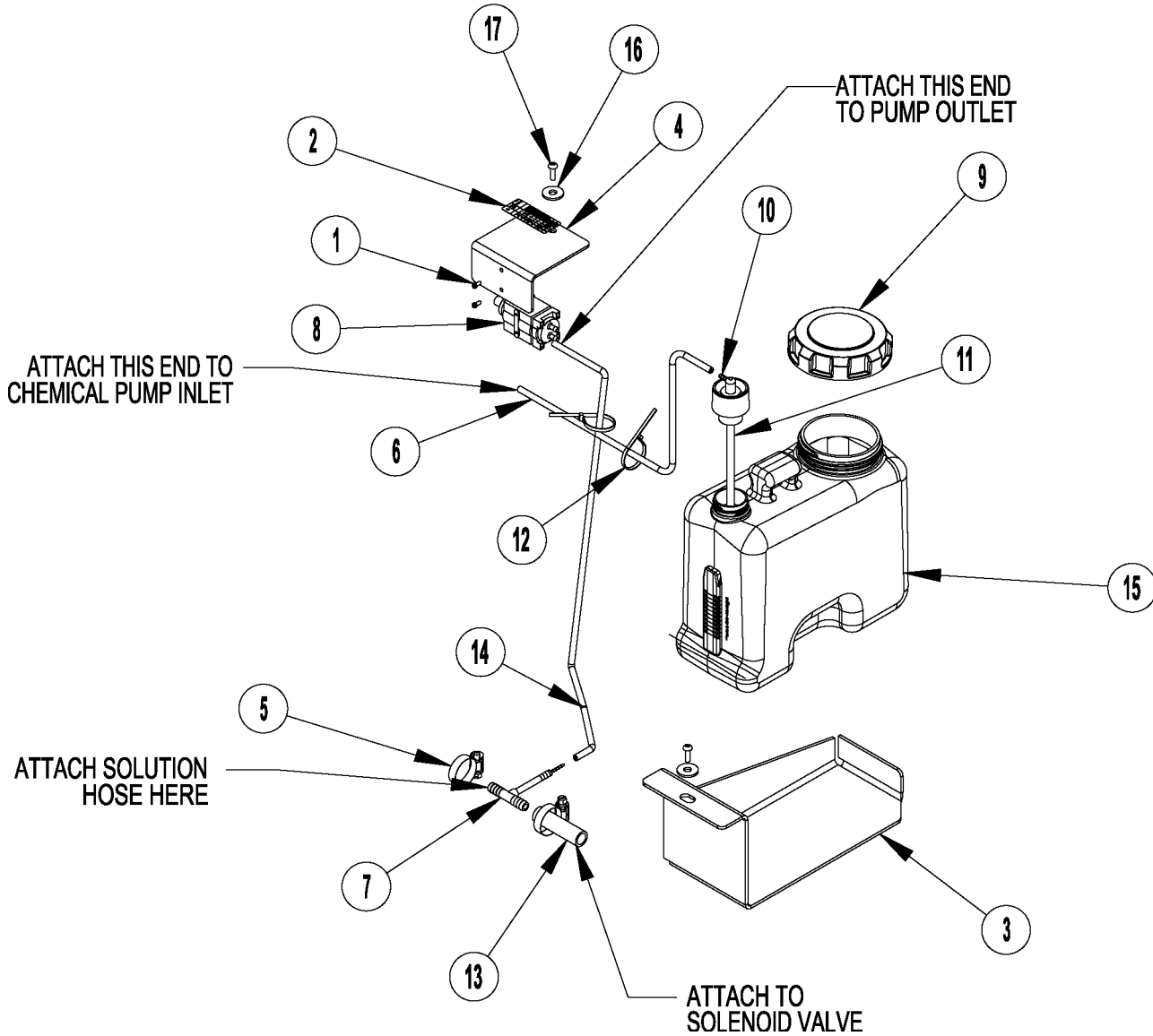

Item	Ref. No.	Qty	Description
1	56002539	2	Scr, Pan Phil Thd Form 6-32 X .31
2	56016331	1	Decal-Chemical Ratio
3	56112125	1	Bracket-Bottle Support
4	56112126	1	Bracket-Pump Mount
5	56244969	2	Clamp- Hose Sae #12
6	56306169	1	Hose, Chem Resistant, 17.00
7	56314983	1	Tee Assembly
8	56315241	1	Pump-Chemical (M6)
9	56315517	1	Cap, Raw
10	56315523	1	Cap, Dry Break, 1/8 Barb, 90°
11	56315527	1	Insert, Dry Break
12	56325219	2	Tie, Cable
13	56392347	1	Hose, Pvc Clear 2.5 Inch
14	56413692	1	Hose, Chem Resistant, 21.00
15	56601544	1	Chemical Bottle Assy
*	56601545	1	Chemical Bottle Assy (Includes 9, 11 & 15)
16	170860	2	Washer, Flat 5/16
17	964004	2	Screw M5-.8 X 16mm Pn St Ph



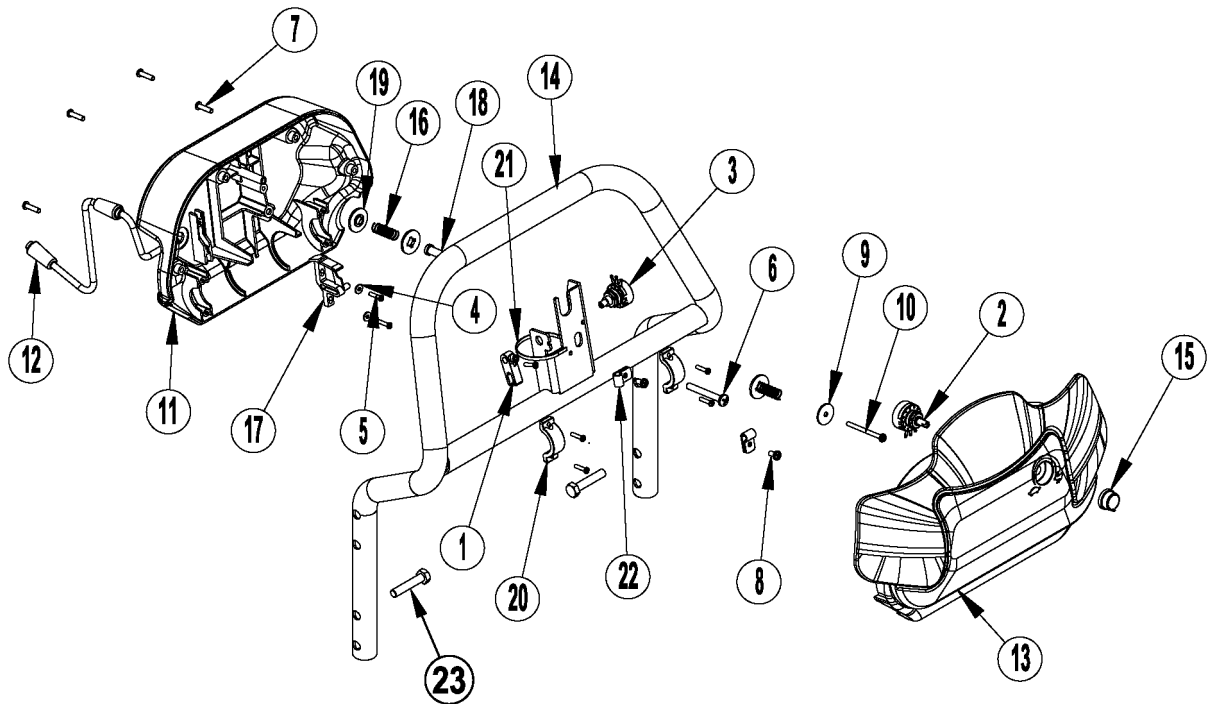

Item	Ref. No.	Qty	Description
	56112218	1	Paddle Assembly (1-22)
1	56109648	1	Potentiometer Fork
2	56396197	1	Potentiometer-Speed Limit (R2)
3	56397029	1	Potentiometer-5k (R1)
4	56002006	2	Wsh, Flt Sae #6
5	56003197	7	Scr, Pan Phil Plastite 6-18 X .62
6	56003527	1	Scr, Pan Phil Plastite 1/4-1 X 2.00
7	56003545	4	Scr, Pan Phil Plastite 8-10 X .75
8	56009030	2	Scr, Pan Phil Thd Form 10-24 X .38
9	56009096	1	Wsh, Flt .193 X .875 X .060
10	56009287	1	Scr, Pan Phil Type B 8 X 2.00
11	56109716	1	Paddle-Back Cover
12	56112179	1	Harness-Paddle
13	56315230	1	Paddle, Front Cover
14	56315251	1	Weldment-Handle Bar
15	56315280	1	Knob
16	56325654	2	Spring - Compression
17	56397015	1	Cam Controller
18	56397109	1	Sleeve
19	56397170	3	Washer, Plastic
20	56397171	2	Clamp
21	56478246	1	Tie, Cable
22	56481890	2	Clamp-P
23#	56002094	4	Scr-Hex 5/16-18 x 1.50

# = Revised or new since last update

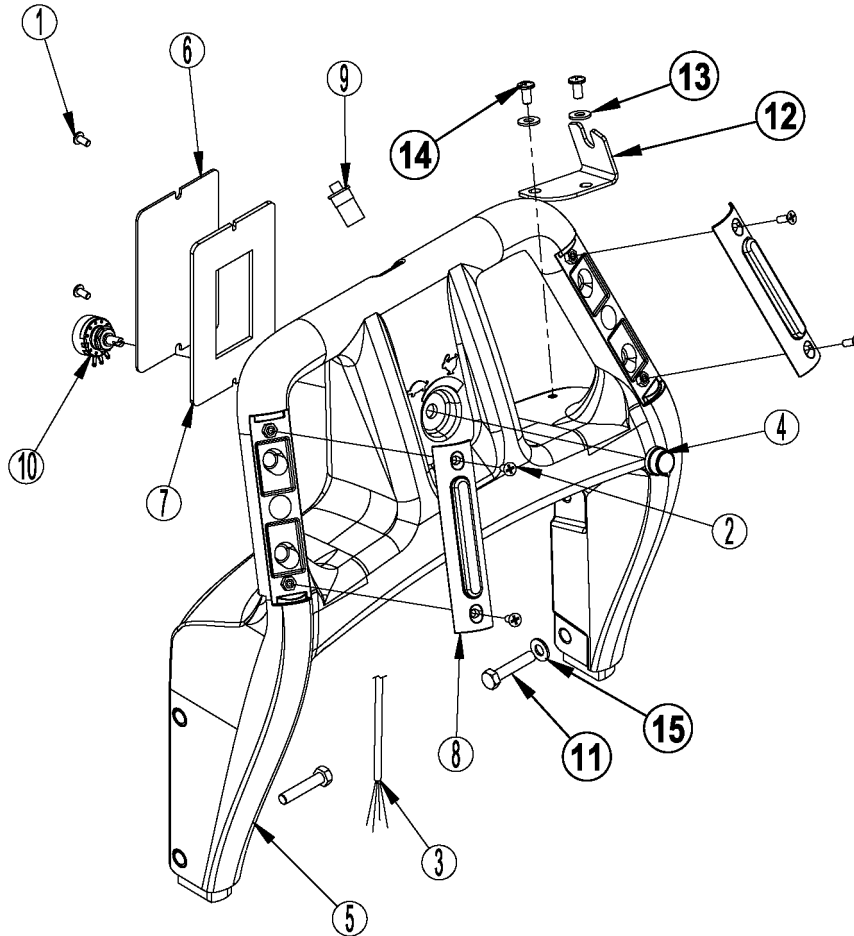

Item	Ref. No.	Qty	Description
	56112219	1	Handle Assembly (1-10)
1	56002043	2	Scr-Pan Phil 10-24 X .38
2	56002178	4	Scr, Flt Phil 10-24 X .50
3	56112186	1	Harness-Handle
4	56315280	1	Knob
5	56315931	1	Handle, Rotomold
6	56315932	1	Access Plate
7	56315933	1	Gasket, Access Panel
8	56315935	2	Palm Switch Assembly (S4 / S5)
9	56315945	1	Switch, Spst Mom. (S6)
10	56315929	1	Potentiometer-Speed Limit (R2)
11	56003437	4	Scr-Hex SS M8-1.25 x 40mm
12	56112299	1	Squeegee Holder
13	56002098	2	Wsh-Fit SAE 1/4
14	56002145	2	Scr-Pan Phil 1/4-20 x .50
15	56001939	4	Wsh-Fit SAE 5/16

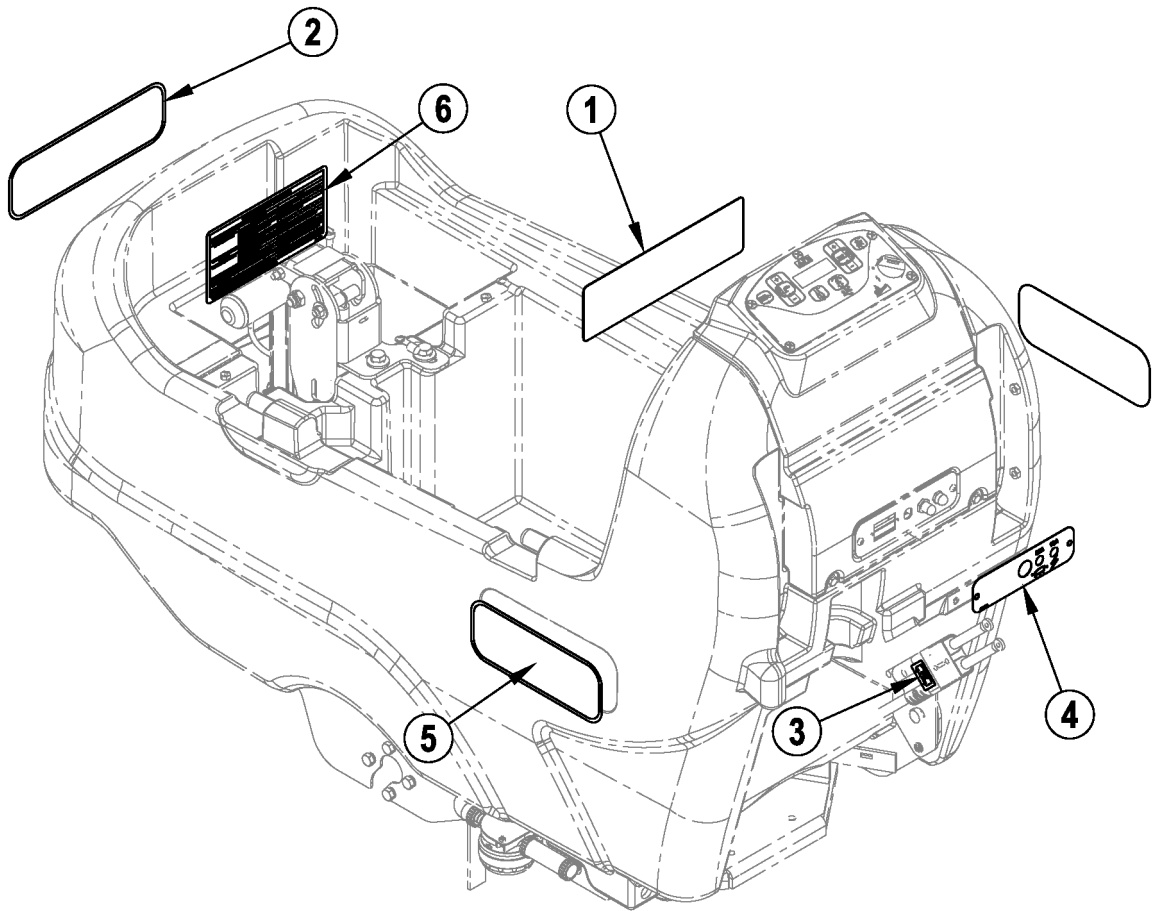

Item	Ref. No.	Qty	Description
1	56014601	1	Decal, Caution
2	56016730	1	Decal-Advance
3	56054192	1	Decal, Charger
4	56112168	1	Decal-Circuit Breaker
5	56112525	2	Decal-SC750
	56112526	2	Decal-SC800
	56112527	2	Decal-SC750 ST
	56112528	2	Decal-SC800 ST
	56112529	2	Decal-SC750 EcoFlex
	56112530	2	Decal-SC800 EcoFlex
6	56112292	1	Decal-Error Codes

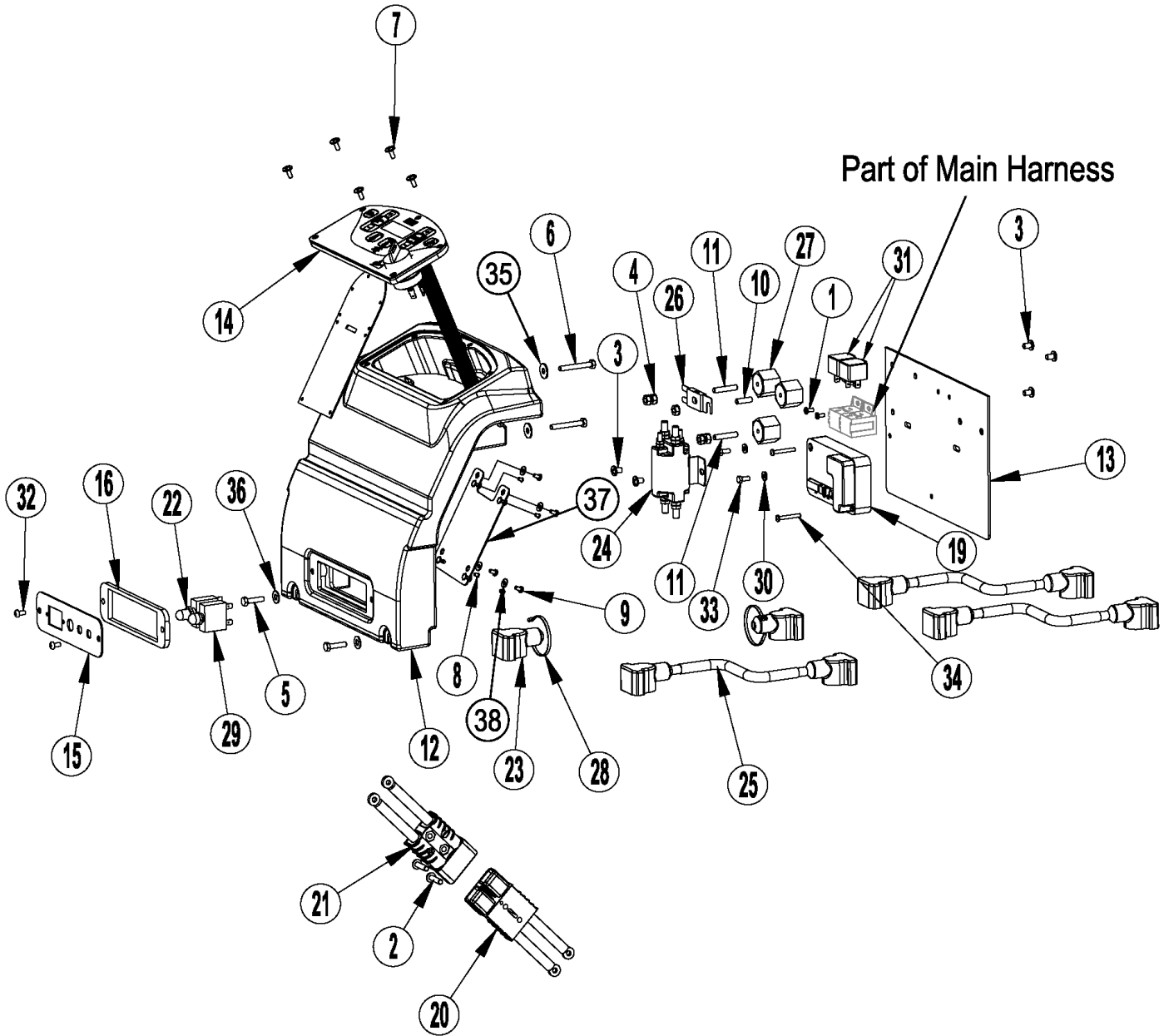

Item	Ref. No.	Qty	Description	Item	Ref. No.	Qty	Description
1	56001818	2	Scr-Pan Phil 8-32 X .38	36	87026a	2	Washer, 1/4 Flat S.S.
2	56002292	2	Scr-Pan Phil 1/4-20 X 1.00	37#	56112535	1	Bracket-PCB Mount
3	56002462	5	Scr-Pan Phil 1/4-20 X .38	38#	56002140	4	Wsh-Fit SAE 8
4	56002561	5	Nut, Hex W/ Shprf 1/4-20	[ ]	56112353	1	Kit-EMC Filter-Cyl (Canada Only)
5	56003430	2	Scr, Hex Ss M6-1 X 25mm	[ ]	56003351	6	Nut Hex M4
6	56003631	2	Scr, Hex M6-1 X 45mm	[ ]	56003354	6	Scr Pan Phil M3.9 X 12.0
7	56003808	5	Scr- Truss Phil Blk M5-0.8 X 12mm	[ ]	56112321	2	Assy-Emc Filter Brush Motor
8#	56003336	4	Scr-Pan Phil Blk 6-32 x .19	[ ]	56112324	1	Assy-Emc Filter Transaxle
9#	56003653	4	Scr-Pan Phil M4-0.7 x 8mm	[ ]	56112328	2	Bracket-Filter
10	56009020	1	Stud	[ ]#	56112534	1	Bracket-Filter Mount
11	56009203	2	Stud, 1/4-20	[ ]#	56002145	2	Scr-Pan Phil 1/4-20 X .50
12	56112112	1	Control Panel	[ ]#	56002491	2	Nut, Hex Nyl Loc Ss 1/4-20
13	56112115	1	Electrical Panel	[ ]	56112349	1	Kit-EMC Filter-Disc (Canada Only)
14	56112119	1	Interface Panel Assy	[ ]	56003174	2	Scr Hex Thd/Hd M6-1.0 X 16mm
[ ]	56303553	1	Switch-Key (S3)	[ ]	56003351	4	Nut Hex M4
*	56303526	1	Replacement Key Set	[ ]	56003354	4	Scr Pan Phil M3.9 X 12.0
*	56112253	1	Kit-Interface Panel (Membrane Switch, Membrane Panel, Gasket)	[ ]	56003403	2	Nut Hex Nyl Loc M6 X 1.00
15	56112122	1	Plate-Circuit Breaker	[ ]	56112321	2	Assy-Emc Filter Brush Motor
16	56112131	1	Gasket	[ ]	56112324	1	Assy-Emc Filter Transaxle
[17]	56112169	1	Cable-Jumper	[ ]	56112340	1	Filter Mount Weldment
[18]	56112174	1	Harness-Main	[ ]#	56112534	1	Bracket-Filter Mount
19	56112187	1	Speed Controller 70a 24v (A2)	[ ]#	56002145	2	Scr-Pan Phil 1/4-20 X .50
20	56112188	1	Connector Assy	[ ]#	56002491	2	Nut, Hex Nyl Loc Ss 1/4-20
21	56112189	1	Connector Assy	[ ]#			
22	56315256	1	Circuit Breaker, 30 Amp (CB1)	[ ]			
23	56372673	2	Boot-Battery Post	[ ]			
24	56397088	1	Contact, 24v Spdt (K2)	[ ]			
25	40172A	3	Cable, Battery	[ ]			
26	56412089	1	Fuse, 150 Amp (F1)	[ ]			
27	56469858	3	Electrical Mount	[ ]			
28	56478246	2	Tie, Cable	[ ]			
29	56507644	1	Circuit Breaker, 10 Amp (CB2)	[ ]			
30	980643	2	Washer 7/16 Od X .036 Thk	[ ]			
31	41075a	2	Relay, 40A (K1 / K3)	[ ]			
32	80193a	2	Screw, M5 X 0.8 X 10mm P.H.	[ ]			
33	80249a	2	Screw, Hex Thd To Hd M5x12	[ ]			
34	80380a	2	Screw, 8-32 X 1 1/4" P.H.	[ ]			
35#	56385358	2	Washer	[ ]			

[ ] = Not Shown

\* = Optional, Not Included

# = Revised or new since last update

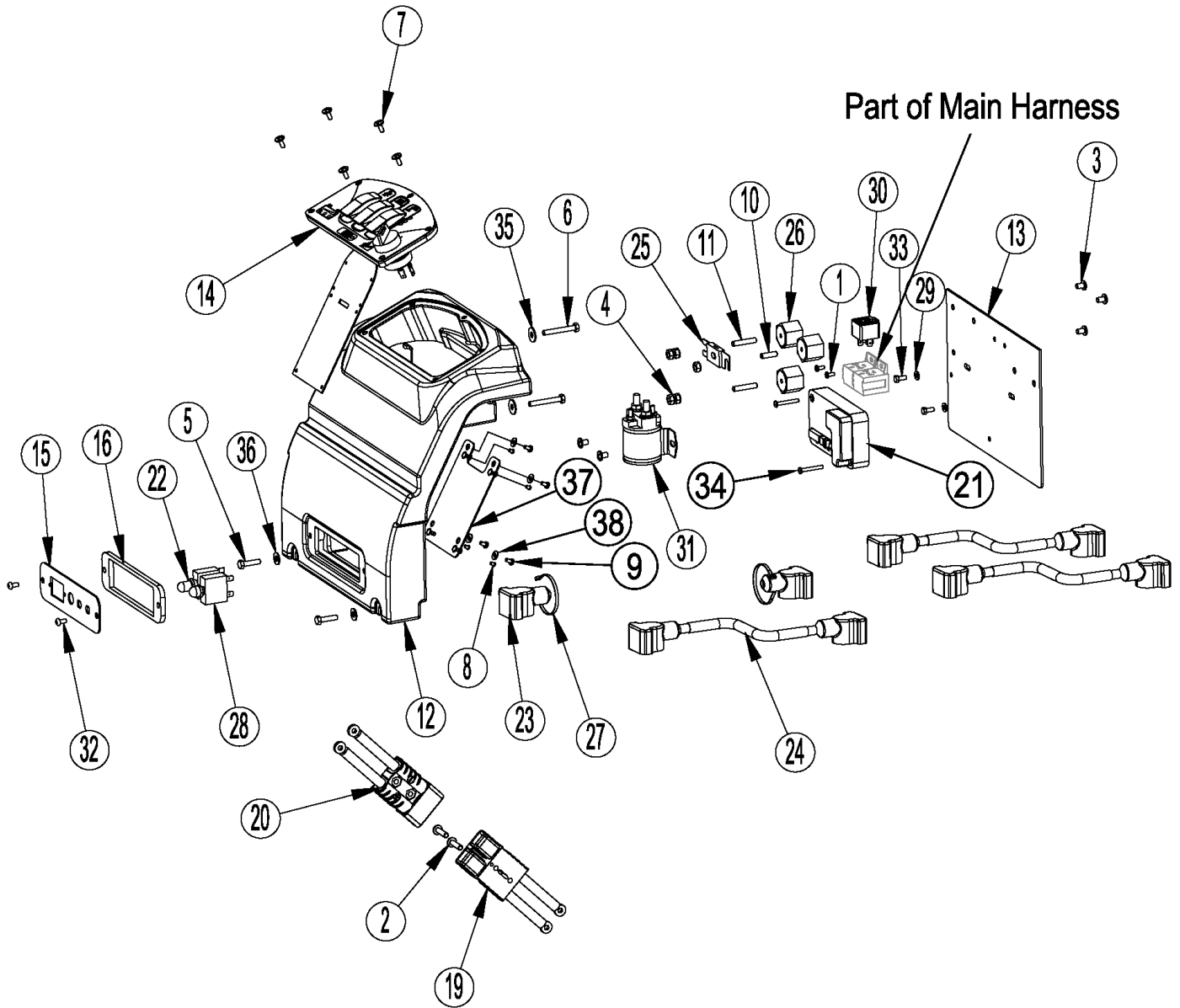

Item	Ref. No.	Qty	Description	Item	Ref. No.	Qty	Description
1	56001818	2	Scr-Pan Phil 8-32 X .38	36	87026a	2	Washer, 1/4 Flat S.S.
2	56002292	2	Scr-Pan Phil 1/4-20 X 1.00	37#	56112535	1	Bracket-PCB Mount
3	56002462	5	Scr-Pan Phil 1/4-20 X .38	38#	56002140	4	Wsh-Flt SAE 8
4	56002561	5	Nut, Hex W/ Shprf 1/4-20	[ ]	56112353	1	Kit-EMC Filter-Cyl (Canada Only)
5	56003430	2	Scr, Hex Ss M6-1 X 25mm	[ ]	56003351	6	Nut Hex M4
6	56003631	2	Scr, Hex M6-1 X 45mm	[ ]	56003354	6	Scr Pan Phil M3.9 X 12.0
7	56003808	5	Scr- Truss Phil Blk M5-0.8 X 12mm	[ ]	56112321	2	Assy-Emc Filter Brush Motor
8#	56003336	4	Scr-Pan Phil Blk 6-32 x .19	[ ]	56112324	1	Assy-Emc Filter Transaxle
9#	56003653	4	Scr-Pan Phil M4-0.7 x 8mm	[ ]	56112328	2	Bracket-Filter
10	56009020	1	Stud	[#]	56112534	1	Bracket-Filter Mount
11	56009203	2	Stud, 1/4-20	[#]	56002145	2	Scr-Pan Phil 1/4-20 X .50
12	56112112	1	Control Panel	[#]	56002491	2	Nut, Hex Nyl Loc Ss 1/4-20
13	56112115	1	Electrical Panel	[ ]	56112349	1	Kit-EMC Filter-Disc (Canada Only)
14	56112120	1	Interface Panel Assy-ST	[ ]	56003174	2	Scr Hex Thd/Hd M6-1.0 X 16mm
[ ]	56112190	3	Switch-Momentary Rocker (S7 / S8 / S9)	[ ]	56003351	4	Nut Hex M4
[ ]	56303553	1	Switch-Key (S3)	[ ]	56003354	4	Scr Pan Phil M3.9 X 12.0
*	56303526	1	Replacement Key Set	[ ]	56003403	2	Nut Hex Nyl Loc M6 X 1.00
*	56112254	1	Kit-Interface Panel ST (Membrane Switch, Membrane Panel, Gasket)	[ ]	56112321	2	Assy-Emc Filter Brush Motor
15	56112122	1	Plate-Circuit Breaker	[ ]	56112324	1	Assy-Emc Filter Transaxle
16	56112131	1	Gasket	[ ]	56112340	1	Filter Mount Weldment
[17]	56112169	1	Cable-Jumper	[#]	56112534	1	Bracket-Filter Mount
[18]	56112174	1	Harness-Main	[#]	56002145	2	Scr-Pan Phil 1/4-20 X .50
19	56112188	1	Connector Assy	[#]	56002491	2	Nut, Hex Nyl Loc Ss 1/4-20
20	56112189	1	Connector Assembly	[ ] = Not Shown			
21	56112241	1	Speed Controller 70a 24v (A2)	* = Optional, Not Included			
22	56315256	1	Circuit Breaker, 30 Amp (CB1)	# = Revised or new since last update			
23	56372673	2	Boot-Battery Post				
24	40172A	3	Cable,Battery				
25	56412089	1	Fuse, 150 Amp (F1)				
26	56469858	3	Electrical Mount				
27	56478246	2	Tie, Cable				
28	56507644	1	Circuit Breaker, 10 Amp (CB2)				
29	980643	2	Washer 7/16 Od X .036 Thk				
30	41075a	1	Relay, 40a (K1)				
31	41810a	1	Contact, Brush 24v (K2)				
32	80193a	2	Screw, M5 X 0.8 X 10mm P.H.				
33	80249a	2	Screw, Hex Thd To Hd M5x12				
34	80380a	2	Screw, 8-32 X 1 1/4" P.H.				
35#	56385358	2	Washer				

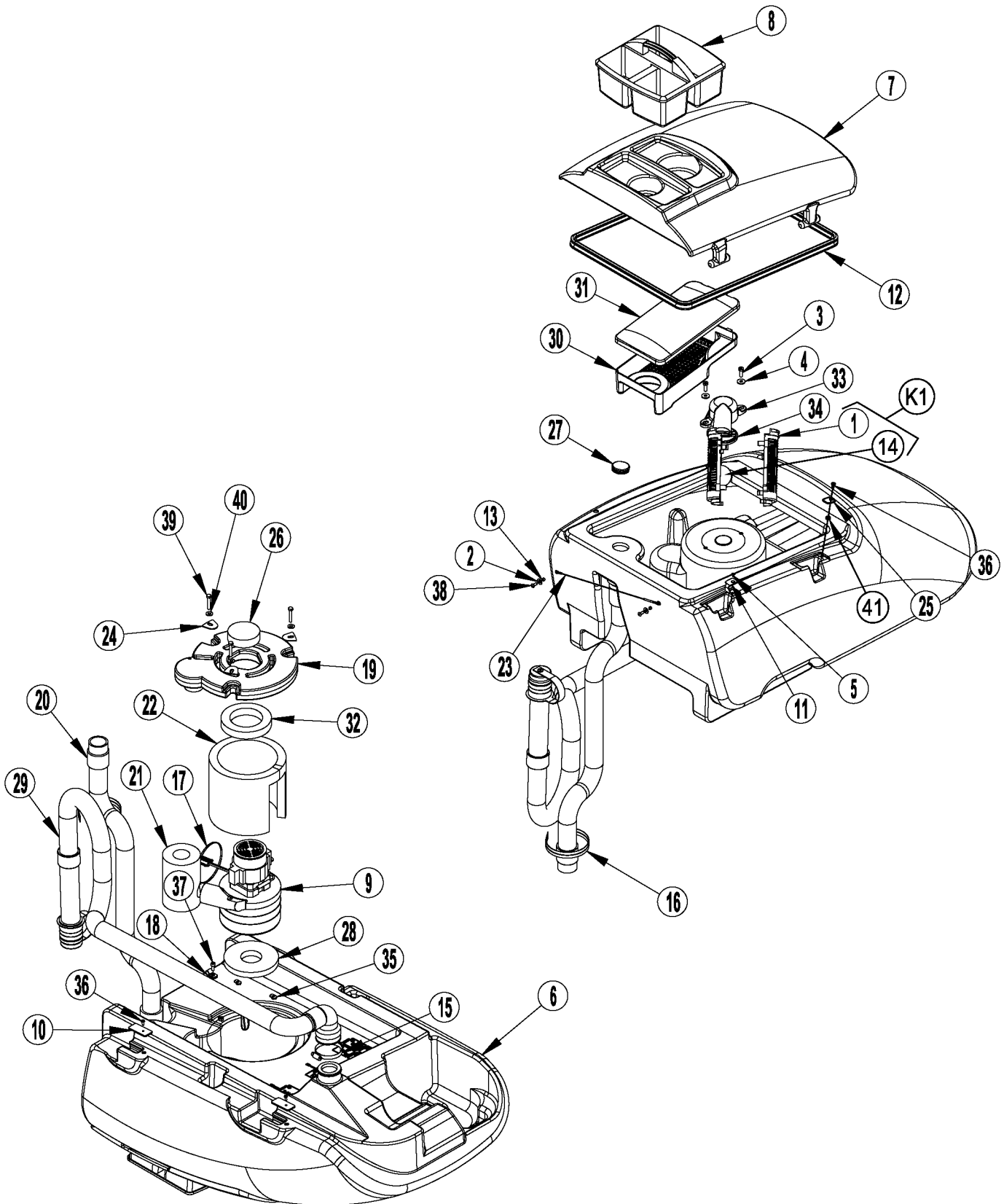



**RECOVERY SYSTEM****SC750, SC800, SC750 ST, SC800 ST**

Item	Ref. No.	Qty	Description
(K1)1		2	Cage, Float
2	56002053	2	Wsh, Flt Std #10
3	56003443	2	Scr, Pan Phil M6-1 X 20mm
4	56003638	2	Wsh, Flt Ss 6mm
5	56003823	1	Scr-Flt Phil Ss M4-0.7 X 8mm
6	56112106	1	Recovery Tank <b>(SC750 models)</b>
	56112102	1	Recovery Tank <b>(SC800 models)</b>
7	56112107	1	Recovery Lid <b>(SC750 models)</b>
	56112103	1	Recovery Lid <b>(SC800 models)</b>
8	56112222	1	Utility Caddy
9	56112239	1	Vac Motor-24 Vdc <b>(M5)</b>
*	56380529	1	Carbon Brush Set of 2
10	56112293	2	Retainer Plate
11	56112296	1	Retainer Plate
12	56112297	1	Gasket-Recovery Lid
13	56151092	2	Bushing
(K1)14		1	Ball, Float
15	56440213	2	Clamp- Hose Sae #32
16	56477613	2	Tie, Cable
17	56478523	1	Tie, Cable
18	56323260	2	Clamp-P
19	9096051000	1	Vacuum Motor Cover
20	56112316	1	Suction Hose
21	9096442000	1	Insulation Tube
22	9096491000	1	Panel, Acoustic Insulation
23	9096634000	1	Stop Tank Cable
24	9096638000	3	Vacuum Cover Plate
25	9096643000	1	Tank Cover Plate
26	9096672000	1	Filter
27	9096899000	1	Cap - Tank
28	9096918000	1	Gasket Vacuum Motor
29	56112310	1	Drain Hose-Recovery
30	9097384000	1	Debris Tray
31	9097477000	1	Debris Tray Cover
32	9097555000	1	Gasket, Vacuum Motor
33	9097587000	1	Support Float System
34	9097588000	1	Gasket Float Support
35	9097589000	2	Nut Drivin 6x6 Ss
36	80057a	3	Screw, M4-.7x10
37	80179a	2	Screw, M6 X 15
38	80363a	2	Screw M5-.8x12 Bt
39	80410a	3	Screw, 6mm X 1.00 X 35mm Lg Hex
40	87026a	3	Washer, 1/4 Flat S.S.
41	9096679000	1	Spacer
K1	56112303	1	Kit-Float Ball Cage

\* = Optional, Not Included

SCRUB SYSTEM (DISK)

10-7

18

SC750, SC800, SC750 ST, SC800 ST

2010-10

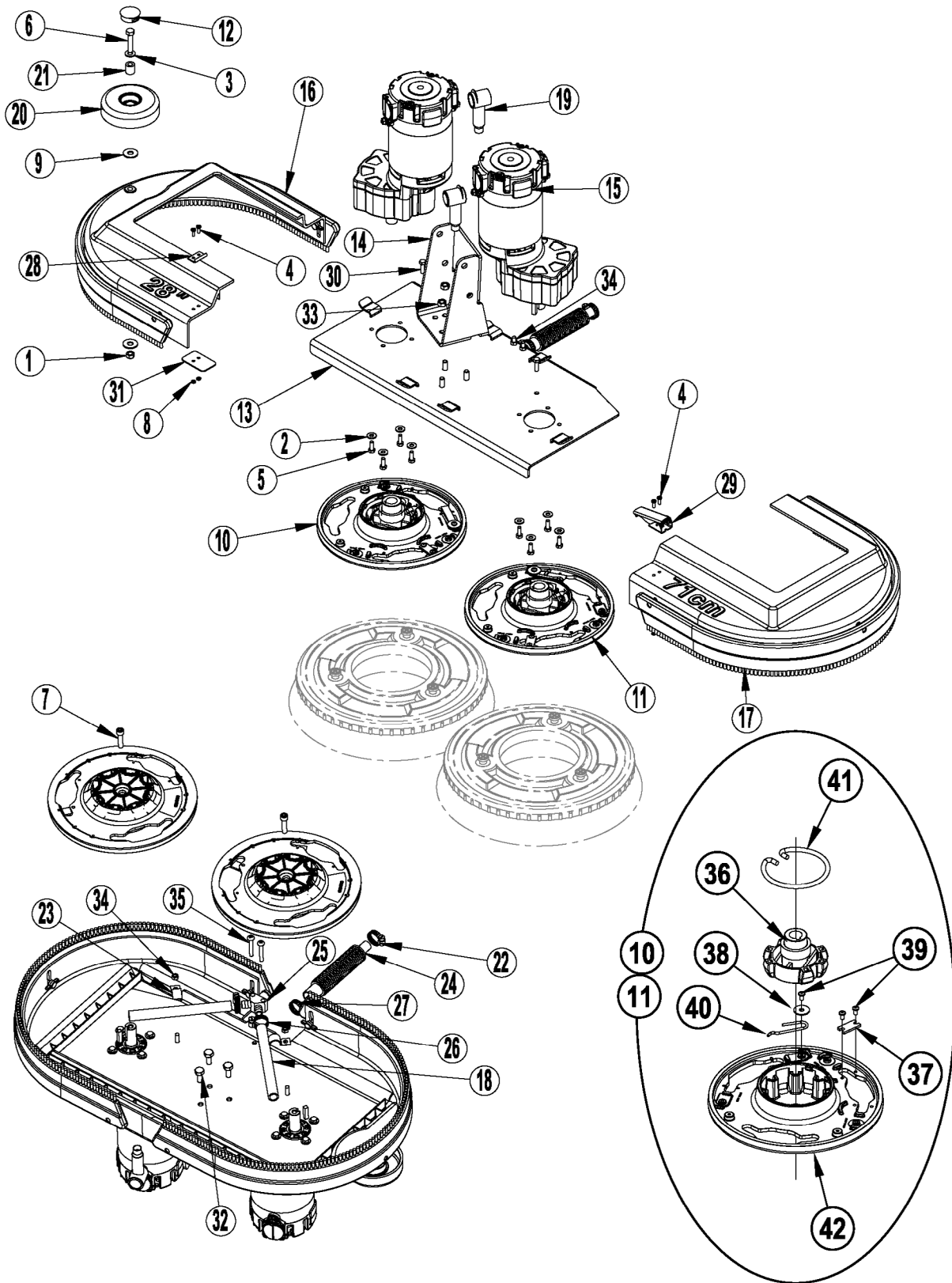

Item	Ref. No.	Qty	Description
1	56002851	1	Nut, Hex Nyl Loc-Thin SS 5/16-18
2	56002859	8	Wsh, Flt Sae SS 1/4
3	56002938	1	Wsh, Flt Sae SS 5/16
4	56003354	4	Scr,Pan Phil Metric
5	56003431	8	Scr, Hex SS M6-1 X 16mm
6	56003455	1	Scr- Hex SS 5/16-18 X 1.50
7	56003798	2	Scr, Soc Hd 5/16-18 X 1.25 Zinc Plated
8	56003821	4	Nut-Hex Nyl Loc Thin M4-.07
9	56009213	2	Wsh, Flt .392x1.00x.075
10	56109651	1	Brush Plate Assy – CCW (36-43)
11	56109652	1	Brush Plate Assy – CW (36-43)
12	56111444	1	Button Plug-1.25
13	56112231	1	Brush Plate Weldt 26D (26" models)
[ ]	56112232	1	Brush Plate Weldt 28D (28" models)
[ ]	56112233	1	Brush Plate Weldt 34D (34" models)
14#	56112523	1	Linkage Bracket
15	56112240	2	Motor Gearbox Assy (M3 / M4)
*	56112242	2	Carbon Brush
16	56112257	1	Brush Skirt Assy-26D Left (26" models)
16	56112259	1	Brush Skirt Assy-28D Left (28" models)
16	56112261	1	Brush Skirt Assy-34D Left (34" models)
17	56112258	1	Brush Skirt Assy-26D Right (26" models)
17	56112260	1	Brush Skirt Assy-28D Right (28" models)
17	56112262	1	Brush Skirt Assy-34D Right (34" models)
[ ]	56112305	1	Kit-Bristle Skirt 26 (26" models / Includes two skirts and mounting hardware)
[ ]	56112306	1	Kit-Bristle Skirt 28 (28" models / Includes two skirts and mounting hardware)
[ ]	56112307	1	Kit-Bristle Skirt 34 (34" models / Includes two skirts and mounting hardware)
18	34705A	2	Hose-Solution 6.00 (26" models)
	56397207	2	Hose, PVC Clear 7.00 (28" models)
	30453A	2	Hose-Clear Vinyl (34" models)
19	56493357	2	Insulator, Terminal (28" & 34" models)
20	56601450	1	Wheel, 4.00 OD
21	56601499	1	Bushing, Nylon
22	722030	1	Clamp, Hose
23	782002	2	Clamp, Manifold
24	30412a	1	Hose, Solution
25	38014a	1	Splitter, Solution
26	50248a	2	Clamp, Hose
27	53571a	1	Clamp, Hose
28	55451a	1	Keeper, Latch
29	55721a	1	Latch, Southco 91-512-07
30	57994a	2	Screw, M6- 1 X 20
31	69186a	1	Tab, Latch, Brush
32	80183a	3	Bolt, M8-1.25 X 20, Hex
33	80198a	3	Nut, M8 -1.25 Nylock S.S.
34	80199a	4	Nut, M6 -1.00 Nylock S.S.
35	88627a	2	Screw, M6-1 X 40mm Ph
36	56112521	1	Gimbal Assembly
37	56366455	1	Plate, Stop
38	56009002	1	Wsh, Flt .266 x .906 x .060
39	56009247	3	Scr, Pan Phil Plasteite 10-14 x .38
40	56109653	1	Spring Retainer
41	56601056	1	Spring, Brush Holder
42	56601118	1	Brush Plate

[ ] = Not Shown

\* = Optional, Not Included

# = Revised or new since last update

SCRUB SYSTEM (CYLINDRICAL)

10-7

20

SC750, SC800, SC750 ST, SC800 ST

2010-10

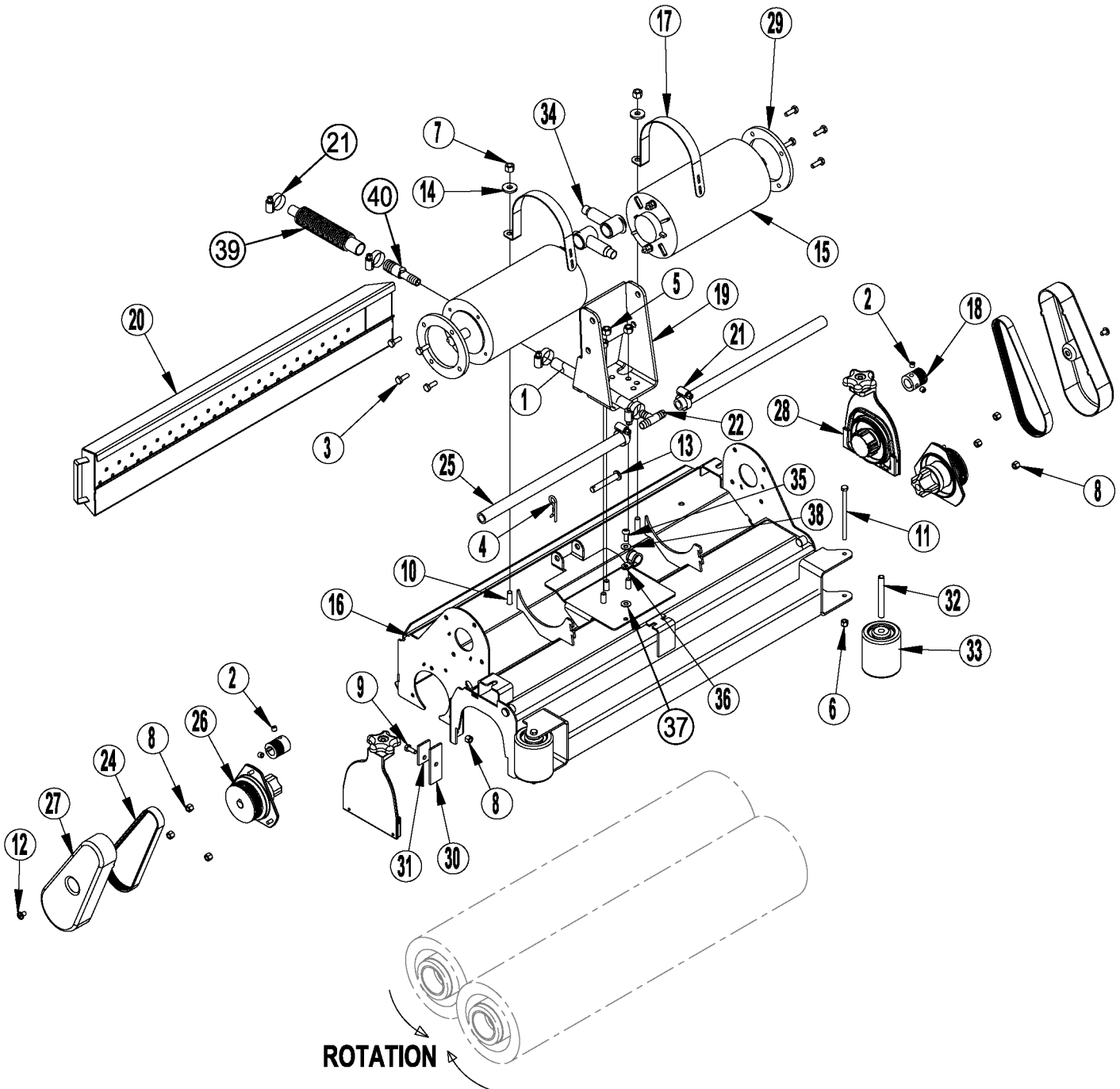

Item	Ref. No.	Qty	Description
1	56397207	1	Hose
2	56002086	4	Scr, Soc Set Loc 5/16-18 X .25
3	56002948	8	Scr, Hex Hd Loc 1/4-20x.75
4	56003222	1	Pin, Cotter Hair
5	56003389	3	Nut-Hex Nyl Loc M8-1.25
6	56003403	2	Nut-Hex Nyl Loc M6-1
7	56003405	2	Nut, Hex Nyl Loc Ss M8-1.25
8	56003426	8	Nut, Hex Nyl Loc Ss M6-1
9	56003431	2	Scr, Hex Ss M6-1 X 16mm
10	56003436	2	Scr, Hex Ss M8-1.25 X 25mm
11	56003492	2	Scr, Hex M6-1 X 95mm
12	56003603	2	Scr, Pan Phil Thd Form 1/4-20 X .38
13	56003656	1	Pin-Clevis .375 X 2.25
14	56009122	2	Wsh, Flt .344 X .938 X .125
15	56112111	2	Motor-24 Vdc 3/4hp (M3 / M4)
*	56412257	1	Brush Cap Assy
16	56112161	1	Brush Housing Weldment-28 (28" models)
	56112163	1	Brush Housing Weldment-32 (32" models)
17	56112165	2	Strap-Motor
18	56112166	2	Sheave-Poly-V
19#	56112523	1	Linkage Bracket
20	56112283	1	Hopper Weld't-28 (28" models)
	56112288	1	Hopper Weld't-32 (32" models)
21#	56112771	6	Clamp- Hose Sae #10
22	56262549	1	Tee, Barb
24	56315321	2	Belt, Auto Tension
25	56315355	2	Manifold, Pvc 28 (28" models)
	56315647	2	Manifold, Pvc 32 (32" models)
26	56315408	2	Drive End Assy
27	56315445	2	Cover, Belt
28	56315448	2	Idler End Assy
[ ]	56396254	2	Knob for Idler End Assy
29	56316197	2	Plate, Motor Spacer
30	56407391	2	Blade
31	56410214	2	Strap
32	56412176	2	Bushing
33	56412459	2	Wheel
34	56493357	2	Insulator, Terminal
35	56002066	1	Scr Pan Phil 1/4-20 X .62
36	54779a	1	Clamp P 5/8 Steel
37	56009064	1	Wsh Int Shprf 1/4
38	87026a	1	Washer, 1/4 Flat S.S.
39#	30412A	1	Hose-Solution
40#	56315625	1	Barb-Coupler 1/2 x 3/4

[ ] = Not Shown

\* = Optional, Not Included

# = Revised or new since last update

**SOLUTION SYSTEM**

10-7

22

**SC750, SC800, SC750 ST, SC800 ST**

2010-10

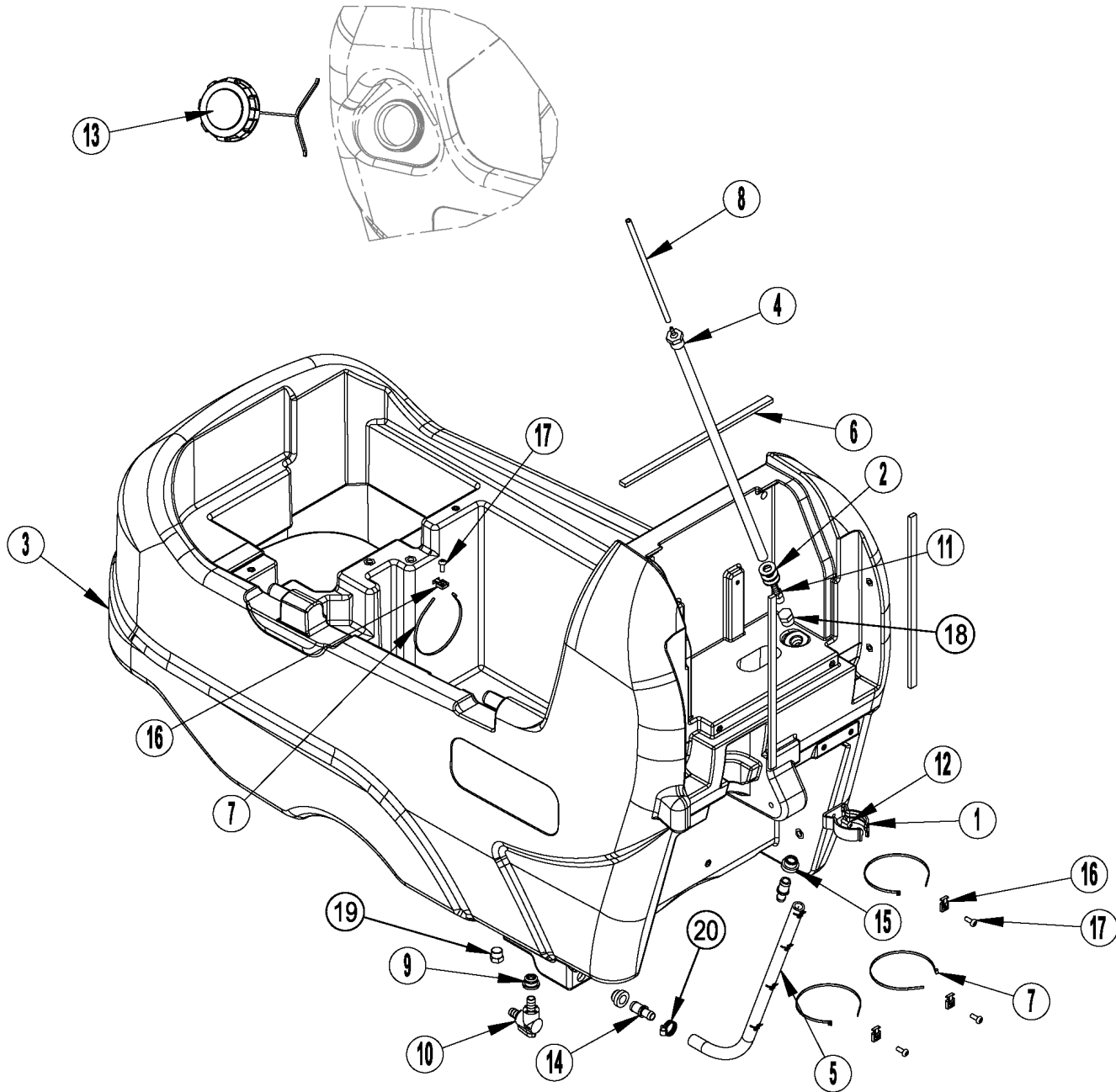

Item	Ref. No.	Qty	Description
1#	L08812967	1	Clamp, Hose D.50
2	56002918	3	Wsh, Flt SAE SS 1/2 (SC750, SC800)
3	56112105	1	Solution Tank (SC750, SC750 ST models)
	56112101	1	Solution Tank (SC800, SC800 ST models)
4	56112145	1	Tube-Pressure Sensing (SC750, SC800)
5	56112347	1	Drain Hose (SC750, SC750 ST models)
	56112348	1	Drain Hose (SC800, SC800 ST models)
6	56419275	3	Gasket, .25 X .50
7	56478523	4	Tie, Cable
8	56601273	1	Hose (SC750, SC800)
9	9095286000	1	Gasket

Item	Ref. No.	Qty	Description
10	9097028000	1	Ball Valve 90°
11	56054691	1	Adaptor-Barb Male (SC750, SC800)
12	964004	1	Screw M5-.8 X 16mm Pn St Ph
13	56601599	1	Cap-Raw With Tether
14	56112346	2	Connector, Straight
15	31242a	2	Bushing
16	52548a	4	Tab, 1/4" Screw
17	80208a	4	Screw, M6 X 1.00 X 10mm Pan Head
18	56305547	1	Plug, 1/2 Hex Pipe (SC750 ST, SC800 ST)
19	56261421	1	Plug-Hex Pipe (SC800, SC800 ST models)
20#	56244969	1	Clamp-Hose SAE 12

# = Revised or new since last update

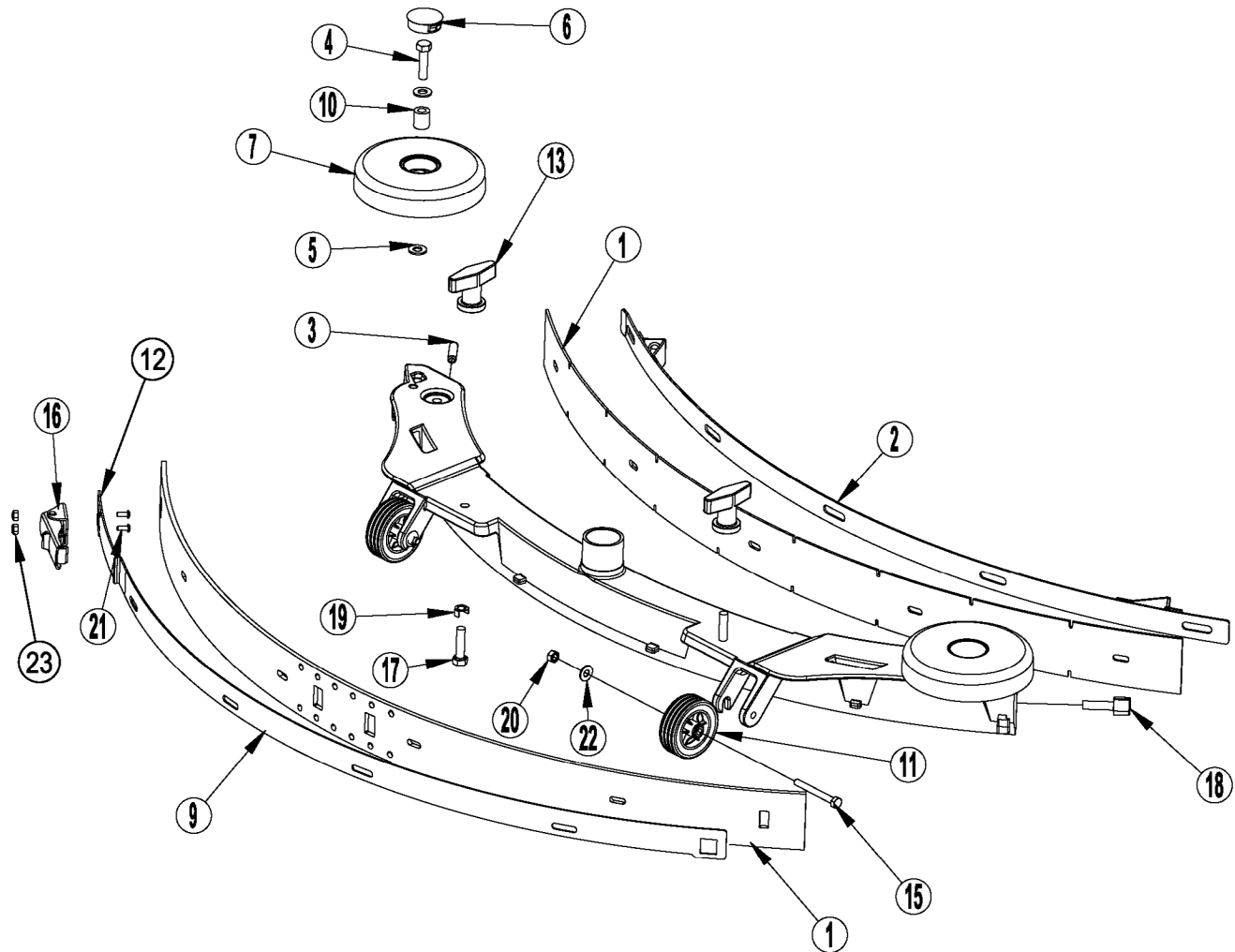

Item	Ref. No.	Qty	Description	Item	Ref. No.	Qty	Description
	56112216	1	Squeegee Assy (26" & 28" models)	17	962157	2	Screw, 5/16-18 X 1.25 Hex Hd
	56112217	1	Squeegee Assy (32" & 34" models)	18	54647a	1	Knob, M8 X 30
1	56112247	1	Blade Kit-Squeegee Gum (26" & 28" models) NOTE 1	19	60564a	2	Shim, Squeegee Knob
	56112250	1	Blade Kit-Squeegee Gum (32" & 34" models) NOTE 1	20	80199a	2	Nut, M6 -1.00 Nyloc S.S.
2	60466a	1	Strap-Squeegee Front (26" & 28" models)	21#	56002909	2	Scr-Pan Phil SS 6-32 x .38
	60546A	1	Strap-Squeegee Front (32" & 34" models)	22	87026a	2	Washer, 1/4 Flat S.S.
3	88632a	1	Scr, Soc Setscrew, Set M8-1.25 X 30mm	23#	56002907	2	Nut-Hex Nyl Loc SS 6-32
4	56002884	2	Scr- Hex Ss 5/16-18 X 1.25				<b>Squeegee Blade Kits for 56112216</b>
5	56002938	4	Wsh, Flt Sae Ss 5/16		56112247	1	Blade Kit-Squeegee Gum NOTE 1
6	56111444	2	Button Plug-1.25	*	56112248	1	Blade Kit-Squeegee Red Gum NOTE 1
7	56112108	2	Wheel	*	56112249	1	Blade Kit-Squeegee PU NOTE 1
9	56112213	1	Strap-Squeegee Rear (26" & 28" models)				<b>Squeegee Blade Kits for 56112217</b>
	56112214	1	Strap-Squeegee Rear (32" & 34" models)		56112250	1	Blade Kit-Squeegee Gum NOTE 1
10	56601499	2	Bushing, Nylon	*	56112251	1	Blade Kit-Squeegee Red Gum NOTE 1
11	9096505000	2	Wheel 90x20 With Bushing	*	56112252	1	Blade Kit-Squeegee PU NOTE 1
12	56112300	1	Rear Latch Strap				
13	9098257000	2	Nut Thumb, Squeegee Fixing				
15	88629a	2	Screw, Hex Thd To Hd M6-1x55				
16#	L08603664	1	Latch, Squeegee				

\* = Optional, Not Included

# = Revised or new since last update

NOTE 1: All squeegee blade kits include both front and rear squeegee blades.



**SQUEEGEE SYSTEM**

10-7

24

SC750, SC800, SC750 ST, SC800 ST

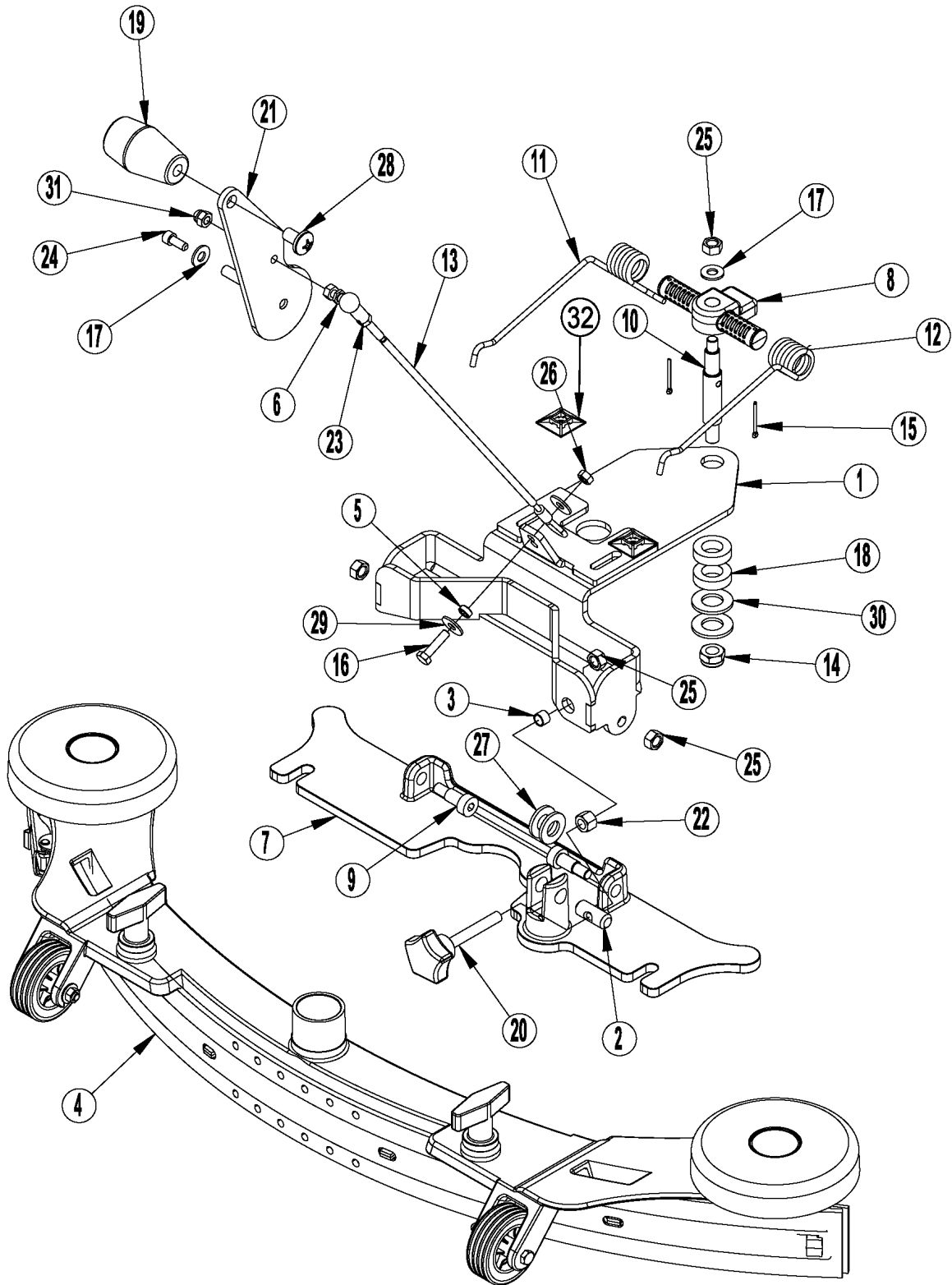



Item	Ref. No.	Qty	Description
1	61953a	1	Plate Squeegee Support
2#	L08601509	1	Pivot Support
3#	L08602422	1	Spacer
4	56112216	1	Squeegee Assy (26" & 28" models / Includes Gum Rubber Blades)
	56112217	1	Squeegee Assy (32" & 34" models / Includes Gum Rubber Blades)
5	1451252000	1	Spacer 6.5x10x4.5
6	1458479000	1	Joint, Ball M6
7	9096045000	1	Squeegee Support
8	9096052000	1	Squeegee Spring Support
9	9096495000	2	Shoulder Screw M10 X 16
10	9096497000	1	Shaft
11	9096537000	1	Push Squeegee Spring
12	9096538000	1	Push Squeegee Spring
13	9097366000	1	Cable, Squeegee Lifting
14	80223a	1	Nut, M10-1.5 Nylock
15	925044	2	Pin, Cotter-.094 X 1.00
16	964054	1	Screw M6-1 X 25mm Hex
17	980651	2	Washer, 5/16 Flat
18	38708a	2	Spacer
19	52557a	1	Knob, Lift
20	54699a	1	Knob, M8 X 55
21	61952a	1	Lever, Squeegee Lift
22	80163a	1	Nut M8-1.25 Hex
23	80171a	1	Nut, M6 Hex
24	80179a	1	Screw, M6 X 15
25	80198a	4	Nut, M8 -1.25 Nylock S.S.
26	80199a	1	Nut, M6 -1.00 Nylock S.S.
27	80424a	2	Washer Flat
28	85389a	1	Screw, 3/8-16 X 5/8
29	87007a	2	Washer Control Shaft
30	87613a	2	Washer Flat 1.22 X .64 X .10 Nylon
31	88640a	1	Nut, M6-1 Acorn
32	9096635000	2	Self-Adhesive Sideburns

# = Revised or new since last update

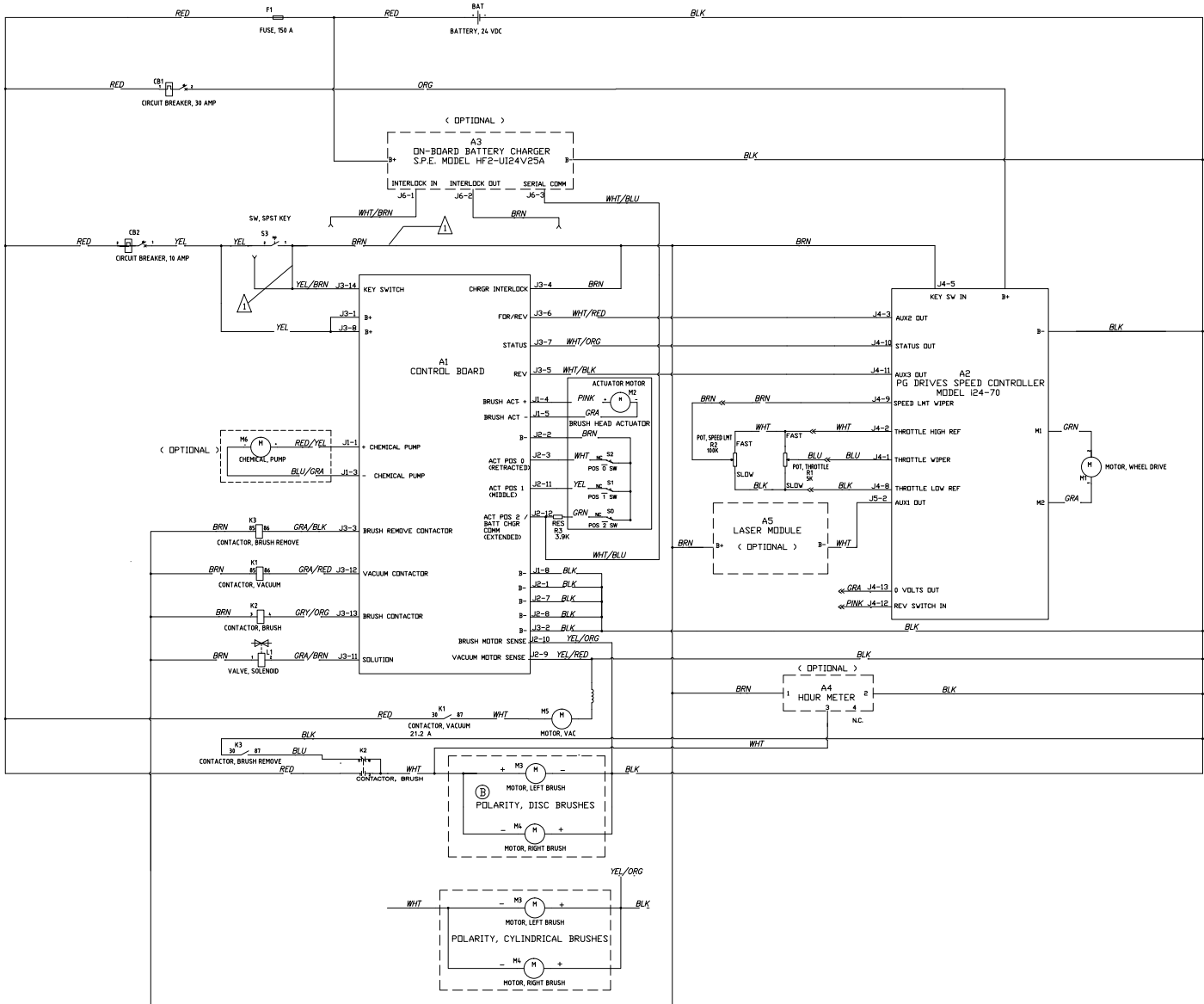

Item	Ref. No.	Qty	Description
A1	NA	1	Control Board
A2	56112187	1	Speed Controller 70a 24v
A3	56112243	1	Battery Charger 24v 25a <b>(Optional)</b>
A4	56393718	1	Hour Meter <b>(Optional)</b>
A5	56112136	1	Laser Module <b>(Optional)</b>
BAT	NA		Battery-24VDC
F1	56412089	1	Fuse, 150 Amp
CB1	56315256	1	Circuit Breaker-30 Amp
CB2	56507644	1	Circuit Breaker-10 Amp
K1	41075A	1	Contacto-Vacuum
K2	56397088	1	Contacto-Brush
K3	41075A	1	Contacto-Brush Remove
L1	56112147	1	Solenoid-Solution
M1	50981A	1	Motor-Wheel Drive
M2	40280A	1	Motor-Actuator
M3	56112240	1	Motor-Left Brush <b>(Disk)</b>
	56112111	1	Motor-Left Brush <b>(Cylindrical)</b>
M4	56112240	1	Motor-Righ Brush <b>(Disk)</b>
	56112111	1	Motor-Left Brush <b>(Cylindrical)</b>
M5	56112239	1	Motor-Vacuum
M6	56315241	1	Pump-Chemical <b>(Optional)</b>
R1	56397029	1	Potentiometer, 5K Ohm, Throttle
R2	56396197	1	Potentiometer-Speed Limit
R3	NA	1	Part of Main Wiring Harness
S0	NA	1	Part of M2
S1	NA	1	Part of M2
S2	NA	1	Part of M2
S3	56303553	1	Switch, Key

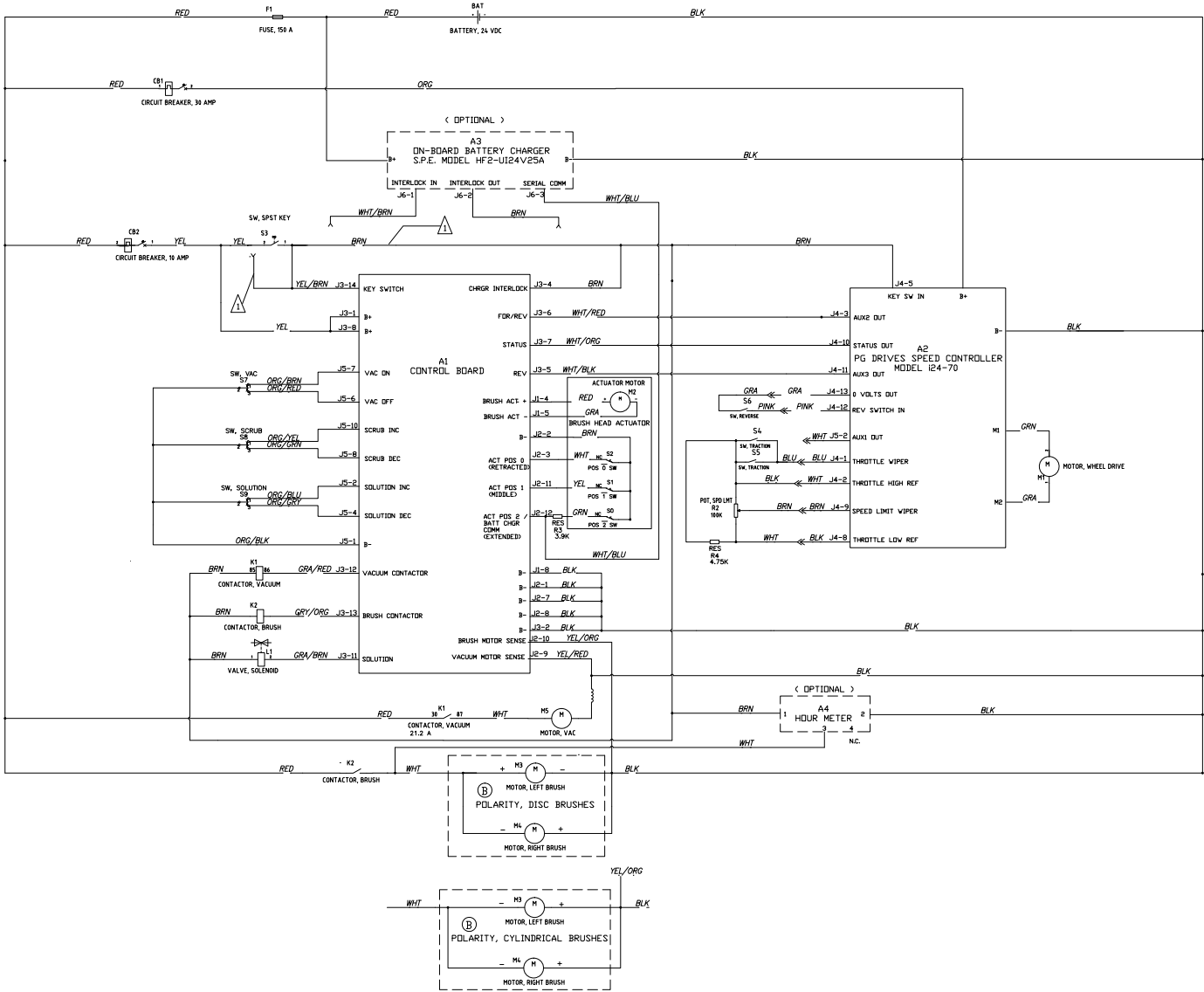

Item	Ref. No.	Qty	Description
A1	NA	1	Control Board
A2	56112241	1	Speed Controller 70a 24v
A3	56112243	1	Battery Charger 24v 25a (Optional)
A4	56393718	1	Hour Meter (Optional)
BAT	NA		Battery-24VDC
F1	56412089	1	Fuse, 150 Amp
CB1	56315256	1	Circuit Breaker-30 Amp
CB2	56507644	1	Circuit Breaker-10 Amp
K1	41075A	1	Contacto-Vacuum
K2	41810A	1	Contacto-Brush
L1	56112147	1	Solenoid-Solution
M1	50981A	1	Motor-Wheel Drive
M2	40280A	1	Motor-Actuator
M3	56112240	1	Motor-Left Brush (Disk)
	56112111	1	Motor-Left Brush (Cylindrical)
M4	56112240	1	Motor-Righ Brush (Disk)
	56112111	1	Motor-Left Brush (Cylindrical)
M5	56112239	1	Motor-Vacuum
R2	56315929	1	Potentiometer-Speed Limit
R3	NA	1	Part of Main Wiring Harness
R4	NA	1	Resistor-4.75K
S0	NA	1	Part of M2
S1	NA	1	Part of M2
S2	NA	1	Part of M2
S3	56303553	1	Switch, Key
S4	56315935	1	Switch-Traction
S5	56315935	1	Switch-Traction
S6	56315945	1	Switch-Reverse
S7	56112190	1	Switch-Vacuum
S8	56112190	1	Switch-Scrub
S9	56112190	1	Switch-Solution

**OPTIONAL KITS & ACCESSORIES**

10-7

**30**

**SC750, SC800, SC750 ST, SC800 ST**

Ref. No.	Qty	Description
<b>Kits</b>		
* 56112246	1	Kit-Onboard Charger
* 56112141	1	Kit-VacuumWand With Tote Bag
* 56601527	1	Kit-Battery Watering
* 56302198	1	Kit-Hour Meter
* 56112221	1	Kit-Parking Brake
* 56112138	1	Kit-Laser <b>(SC750, SC800 only)</b>
* 56112140	1	Kit-Wet Floor Sign Holder
* 56112312	1	Kit-Mop Holder
* 56112265	1	Kit-Disk Deck Assy 26
* 56112266	1	Kit-Disk Deck Assy 28
* 56112267	1	Kit-Cylindrical Deck Assy 28
* 56112280	1	Kit-Cylindrical Deck Assy 32
* 56112279	1	Kit-Disk Deck Assy 34

**NOTE:** Replacement parts for the kits listed above can be found on each kit's associated instruction sheet.

**Squeegee Blade Kits for 56112216 (See Squeegee Blade Selector Guide)**

56112247	1	Blade Kit-Squeegee Gum <b>NOTE 1</b>
* 56112248	1	Blade Kit-Squeegee Red Gum <b>NOTE 1</b>
* 56112249	1	Blade Kit-Squeegee PU <b>NOTE 1</b>

**Squeegee Blade Kits for 56112217 (See Squeegee Blade Selector Guide)**

56112250	1	Blade Kit-Squeegee Gum <b>NOTE 1</b>
* 56112251	1	Blade Kit-Squeegee Red Gum <b>NOTE 1</b>
* 56112252	1	Blade Kit-Squeegee PU <b>NOTE 1</b>

**Accessories**

* 56112222	1	Utility Caddy
* 56112255	1	Programmer With Cable
* 56397453	6	Indicator-Battery Level <b>(1 per battery)</b>

**Optional Batteries**

* 56206079	4	Battery, 6v 235 A/H Wet <b>TSBUS2008-984</b>
* 56391391	4	Battery, 6v 305 A/H Wet <b>TSBUS2008-984</b>
* 56315959	4	Battery, 6v 312 A/H AGM <b>TSBUS2008-984</b>

**Optional Battery Chargers**

* 56372947	1	Charger, 24vdc Auto 20 Amp 120vac/60hz <b>TSBUS2008-984</b>
* 56388109	1	Charger, 24vdc Auto 25 Amp 120vac/60hz <b>TSBUS2008-984</b>
* 56372203	1	Charger, 24vdc Auto 20 Amp 230vac/50hz <b>TSBUS2008-984</b>

**26" Disk Scrub Brushes (See Brush Selector Guide)**

* 56505760	2	Short Trim Pad Holder
* 56505195	2	Pad Retainer for 56505750
* 56505765	2	ProLite
* 56505764	2	Prolene
* 56505766	2	Union Mix
* 56505763	2	AgLite Grit 500
* 56505767	2	MidGrit 240
* 56505768	2	MidLite Grit 180
* 56505762	2	Dyna Grit 80
* 56505761	2	Magna Grit 46

**28" Disk Scrub Brushes (See Brush Selector Guide)**

* 56505800	2	Short Trim Pad Holder
* 56505195	2	Pad Retainer for 56505750
* 56505805	2	ProLite
* 56505804	2	Prolene
* 56505806	2	Union Mix
* 56505803	2	AgLite Grit 500
* 56505807	2	MidGrit 240
* 56505808	2	MidLite Grit 180
* 56505802	2	Dyna Grit 80
* 56505801	2	Magna Grit 46

**34" Disk Scrub Brushes (See Brush Selector Guide)**

* 56505780	2	Short Trim Pad Holder
* 56505195	2	Pad Retainer for 56505750
* 56505785	2	ProLite
* 56505784	2	Prolene
* 56505786	2	Union Mix
* 56505783	2	AgLite Grit 500
* 56505787	2	MidGrit 240
* 56505788	2	MidLite Grit 180
* 56505782	2	Dyna Grit 80
* 56505781	2	Magna Grit 46

**28" Cylindrical Scrub Brushes (See Brush Selector Guide)**

* 56412191	2	Soft Nylon
* 56412192	2	Hard Nylon
* 56412046	2	Prolene
* 56412193	2	MidLite Grit 180
* 56412194	2	Dyna Grit 80
* 56412195	2	Magna Grit 46

**32" Cylindrical Scrub Brushes (See Brush Selector Guide)**

* 56407473	2	Soft Nylon
* 56407474	2	Hard Nylon
* 56407475	2	Prolene
* 56407476	2	MidLite Grit 180
* 56407477	2	Dyna Grit 80
* 56407478	2	Magna Grit 46

\* = Optional, Not Included

**NOTE 1:** All squeegee blade kits include both front and rear squeegee blades.

We provide brushes and pad holders that will give you the best possible performance between machine and floor. Following are descriptions of the materials and their applications.

- ProLite:** Bristles are made from light-duty polypropylene for general scrubbing when you do not want to scratch or remove finish from the floor. Recommended for use in place of red pads.
- Prolene:** Polypropylene material for medium-duty scrubbing on concrete, terrazzo and vinyl floor tile. Recommended for use in place of green or blue pads.
- Union Mix:** Medium grade natural fibers for polishing finished floors with standard-speed equipment. Recommended for use in place of white pads.
- AgLite Grit 500:** For light scrubbing when used wet; buffing or polishing when used dry on urethane coated, sealed concrete or other resilient hard surface floors. Recommended for use in place of red or white pads.
- MidGrit 240:** For general purpose scrubbing when you need a lighter action for sealed or unsealed concrete, stone, terrazzo, quarry tile and other resilient hard floor surfaces. Recommended for use in place of green or blue pads.
- MidLite Grit 180:** For general purpose scrubbing of sealed or unsealed concrete, stone, terrazzo, quarry tile and other resilient hard floor surfaces. Recommended for use in place of green or blue pads.
- Dyna Grit 80:** For aggressive, heavy-duty scrubbing or stripping of floors. Recommended for use in place of brown pads.
- Magna Grit 46:** For extreme heavy-duty scrubbing or stripping of floors. This brush has extra large diameter silicon carbide grit impregnated synthetic bristles. Recommended for use in place of black pads.
- Short Trim Pad Holder:** Made with a structural foam block and center ring for correct pad centering. It has a "shower feed" design for getting solution to the floor.

**26" BRUSHES**

56505760 - Short Trim Pad Holder  
 56505195 - Pad Retainer for 56505760  
 56505765 - ProLite  
 56505764 - Prolene  
 56505766 - Union Mix  
 56505763 - AgLite Grit 500  
 56505767 - MidGrit 240  
 56505768 - MidLite Grit 180  
 56505762 - Dyna Grit 80  
 56505761 - Magna Grit 46

**28" BRUSHES**

56505800 - Short Trim Pad Holder  
 56505195 - Pad Retainer for 56505800  
 56505805 - ProLite  
 56505804 - Prolene  
 56505806 - Union Mix  
 56505803 - AgLite Grit 500  
 56505807 - MidGrit 240  
 56505808 - MidLite Grit 180  
 56505802 - Dyna Grit 80  
 56505801 - Magna Grit 46

**34" BRUSHES**

56505780 - Short Trim Pad Holder  
 56505195 - Pad Retainer for 56505800  
 56505785 - ProLite  
 56505784 - Prolene  
 56505786 - Union Mix  
 56505783 - AgLite Grit 500  
 56505787 - MidGrit 240  
 56505788 - MidLite Grit 180  
 56505782 - Dyna Grit 80  
 56505781 - Magna Grit 46

**DISC BRUSH APPLICATION GUIDE (SUGGESTION ONLY)**

	<b>46</b>	<b>80</b>	<b>180</b>	<b>240</b>	<b>500</b>			<b>Union</b>
<b>Application</b>	<b>Grit</b>	<b>Grit</b>	<b>Grit</b>	<b>Grit</b>	<b>Grit</b>	<b>Prolene</b>	<b>Prolite</b>	<b>Mix</b>
<b>Stripping:</b>								
Concrete	X	X						
Terrazzo	X	X						
Ceramic/Quarry tile		X						
Vinyl tile		X						
<b>General Scrubbing:</b>								
Concrete	X	X	X	X		X		
Terrazzo			X	X	X	X		
Ceramic/Quarry tile			X	X	X	X		
Marble					X		X	
Vinyl tile			X		X	X		
Raised-rubber tile					X		X	
<b>Polishing:</b>								
Raised Disc Tile								X
Marble								X
Vinyl tile								X

We provide brushes and pad holders that will give you the best possible performance between machine and floor. Following are descriptions of the materials and their applications.

- Soft Nylon: Least aggressive brush available. Used on soft-finish floors where a more aggressive brush would leave scratch marks, or in applications requiring very light cleaning.
- Stiff Nylon: Cleaning action similar to polypropylene. More durable and wear-resistant than polypropylene.
- Prolene: Low cost, yet effective in cleaning many common floor surfaces.
- MidLite Grit 180: Least aggressive grit brush. Used for daily cleaning of hard-finished floors.
- Dyna Grit 80: Medium aggressive grit brush. Good all-around brush for medium to heavy buildup removal. Can also be used for general stripping operations.
- Magna Grit 46: Most aggressive grit brush. Used primarily to clean heavy buildup on concrete floors in factories, or for heavy stripping of finish.

**28" BRUSHES**

- 56412191 - Soft Nylon
- 56412192 - Hard Nylon
- 56412046 - Prolene
- 56412193 - MidLite Grit 180
- 56412194 - Dyna Grit 80
- 56412195 - Magna Grit 46

**34" BRUSHES**

- 56407473 - Soft Nylon
- 56407474 - Hard Nylon
- 56407475 - Prolene
- 56407476 - MidLite Grit 180
- 56407477 - Dyna Grit 80
- 56407478 - Magna Grit 46

**CYLINDRICAL BRUSH APPLICATION GUIDE (SUGGESTION ONLY)**

Application	46 Grit	80 Grit	180 Grit	Polypropylene	Stiff Nylon	Soft Nylon
<b>Stripping:</b>						
Concrete	X	X				
Terrazzo	X	X				
Ceramic/Quarry tile		X				
Vinyl tile		X				
<b>General Scrubbing:</b>						
Concrete	X	X	X	X	X	
Terrazzo			X	X	X	X
Ceramic/Quarry tile			X	X	X	X
Marble			X		X	X
Vinyl tile			X	X	X	X
Raised-rubber tile			X			X



Gum Rubber: Provides superior wiping action on tile, terrazzo, and polished floors.

Linatex™: Provides longest life on finished or unfinished concrete floors.

Polyurethane: Oil resistance provides superior life in applications with oily floors.

**SQUEEGEE BLADE APPLICATION GUIDE(SUGGESTION ONLY)**

<b>Performance Traits</b>	<b>Gum Rubber (Natural Rubber)</b>	<b>Linatex™ (Natural Rubber)</b>	<b>Polyurethane/ Pentathane</b>
Resilience	X		X
Tear Strength	X		X
Abrasion Resistance	X	X	X
Wear Resistance		X	X
Low Temp Flexibility	X	X	
High Temp Flexibility	X		X
Ozone Resistance			
Chemical Resistance			X
<b>Applications</b>			
Oil Resistant Applications			X
General Purpose	X	X	X
Hot Water Applications		X	X
Chemical Applications			X
<b>Color</b>	Tan	Red	Translucent







**Advance**

14600 21st Avenue North  
Plymouth, MN 55447-3408

[www.advance-us.com](http://www.advance-us.com)

Phone: 800-989-2235

Fax: 800-989-6566

©2010 Nilfisk-Advance, Inc.

---

**A Nilfisk-Advance Brand**